

Yamada SOLIDTM PRO

Designed to
Pump Fluids
Containing Solids

Introducing the New Yamada Solids Handling Pump

The company that pioneered the maintenance free, non-lube air valve and the short stroke diaphragm is pleased to introduce the latest in solids handling technology!



- Based on Yamada's field proven NDP Series foundation, this pump has all of the features and benefits associated with every Yamada
- Ingenious Flap Valve design allows for passage of large solids - Up to 2"
- Easy access to valve chambers allows for ease of maintenance when you need it most
- Vented diaphragm chambers serve to alleviate problems associated with trapped air/gas

Clean in place design



**For more information on the
SolidPRO call 888-450-3978**

The **Proof's**
in the **Pump**SM



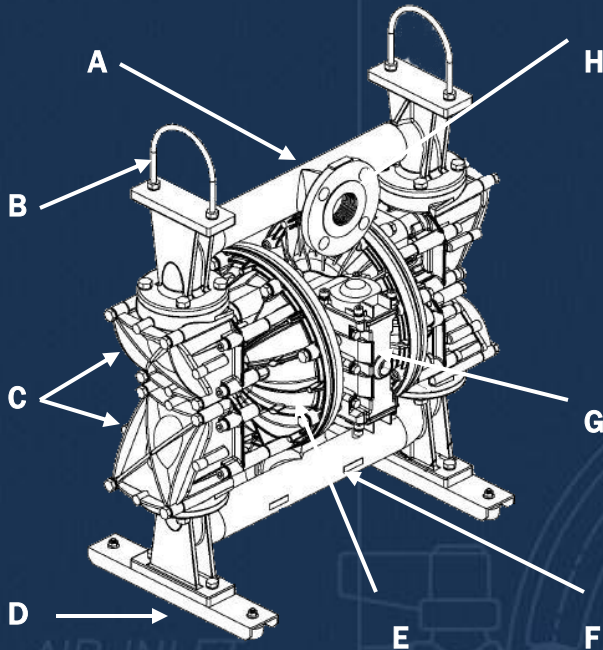

- A. Suction Manifold
- B. Hauling U-Bolts
- C. Check Valve Chambers with access ports
- D. Removable/Replaceable Legs
- E. Liquid Chamber
- F. Discharge Manifold
- G. Non-Lube Air Motor
- H. 2" Multi-port (ANSI Flange & NPT)

Check Valve Access Ports

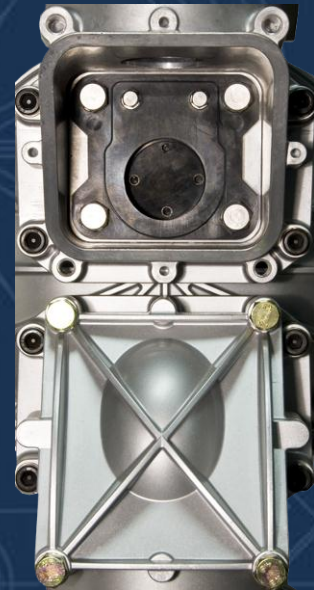

Heavy Duty Flap Check Valve

Access ports enable quick servicing of the pump

Ingenious Flap Valve design allows for passage of large solids – Up to 2" malleable or soft solids

Easy access to valve chambers allows for ease of maintenance when you need it most

Top suction/bottom discharge design will not allow solids to settle in pump

Vented diaphragm chambers serve to alleviate problems associated with trapped air/gas



Just 4 bolts to replace valve!!

The Solid Pro is **EXTREMELY ADAPTABLE!**

INDUSTRIES SERVED

- ◇ Municipalities
- ◇ Refineries
- ◇ Food Processing
- ◇ General Industrial
- ◇ Construction
- ◇ Meat Packing
- ◇ Chicken Processing
- ◇ Canning
- ◇ Mining
- ◇ Ceramic
- ◇ Oil & Gas
- ◇ Ink & Coatings

APPLICATION SUCCESSES

- ◇ Deactivated Sludge
- ◇ Mine Dewatering
- ◇ Chicken Skin and Bones
- ◇ Drillers Mud
- ◇ Ceramic Slip
- ◇ Powder
- ◇ Meat Processing Waste
- ◇ DAF Sludge
- ◇ Diatomaceous Earth
- ◇ Solvent Waste
- ◇ Sumps



PROBLEM SOLVER – A chicken processing plant previously had to stop production to remove a full load of chicken waste (every 2 hours). By incorporating a hopper and a steady stream of water, that problem was solved with the Solid Pro. -

What are Solid Pro users saying....?

“The Cadillac of Pumps”

“This pump has performed perfectly and we have not had one single problem of any kind”

“Indeed, one person could easily move and work on it if needed”

Don't Forget.... The Solid Pro comes with all the benefits of every Yamada Pump

- Non-lubricated Air-Valve
- Bolted Construction
- Short Stroke Technology – allowing for longer diaphragm life
- Outside-Accessible Air Valve
- Modular Pilot-Valve Design – no dynamic o-rings to replace or repair

	Yamada NDP-50FA	Leading Competitor
Weight	110 lbs	95 lbs
Dimensions	H 31" W 25-1/2" D 14-1/8"	H 20-5/6" W 21-3/4" D 13-5/8"
Intake & Discharge Ports	2" Multi-port 150# RF Flange & NPT	Only NPT offered
Flow	150 gpm max	140 gpm max
Solids Size	Up to 2" (50 mm)	Up to 2" (50 mm)
Lift	24 feet dry max	20 feet dry max
Air Valve		
Lubrication	No Lubrication Required	Lubrication Required
Manual Override	Yes	None
Liquid Side		
In Place Clean Out Ports	Yes- Can do flapper/seal assy. maintenance without pump removal	None- must be removed from service
Flapper Mating Surfaces	Rubber / Rubber (<i>no gaskets / o-rings</i>)	Rubber / Metal (<i>with gaskets</i>)
Flapper Seal	Raised angled seat compensates for normal wear and faster seating of flap valve	Once worn, will not seal
Flow Through Ports	Angled for maximum flow through	90 degree turns lead to clogging
Diaphragms	Short stroke technology for longer diaphragm life	Over stressed diaphragms lead to accelerated failure

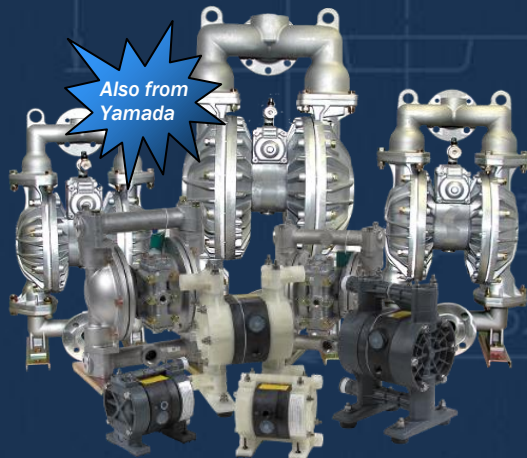
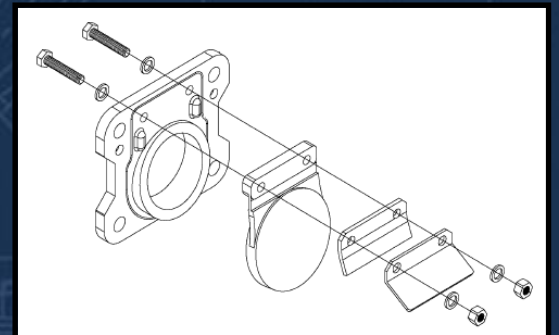
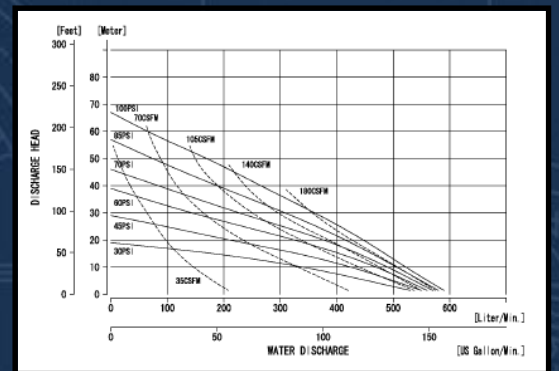
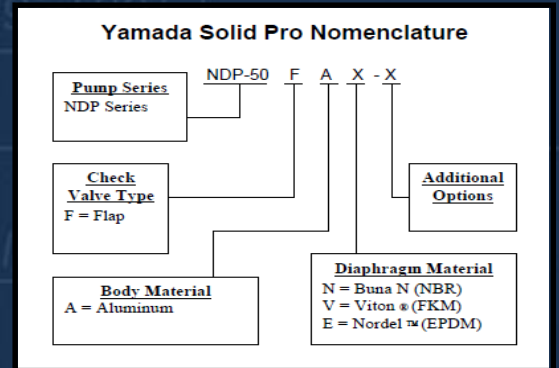

Also from Yamada

Full line of Air-Operated Diaphragm Pumps 1/4" - 3"

The **Proof's**
in the **Pump**™

Your local distributor:

Form# SP1109