

GOULDS PUMPS

INSTALLATION, OPERATION and MAINTENANCE INSTRUCTIONS

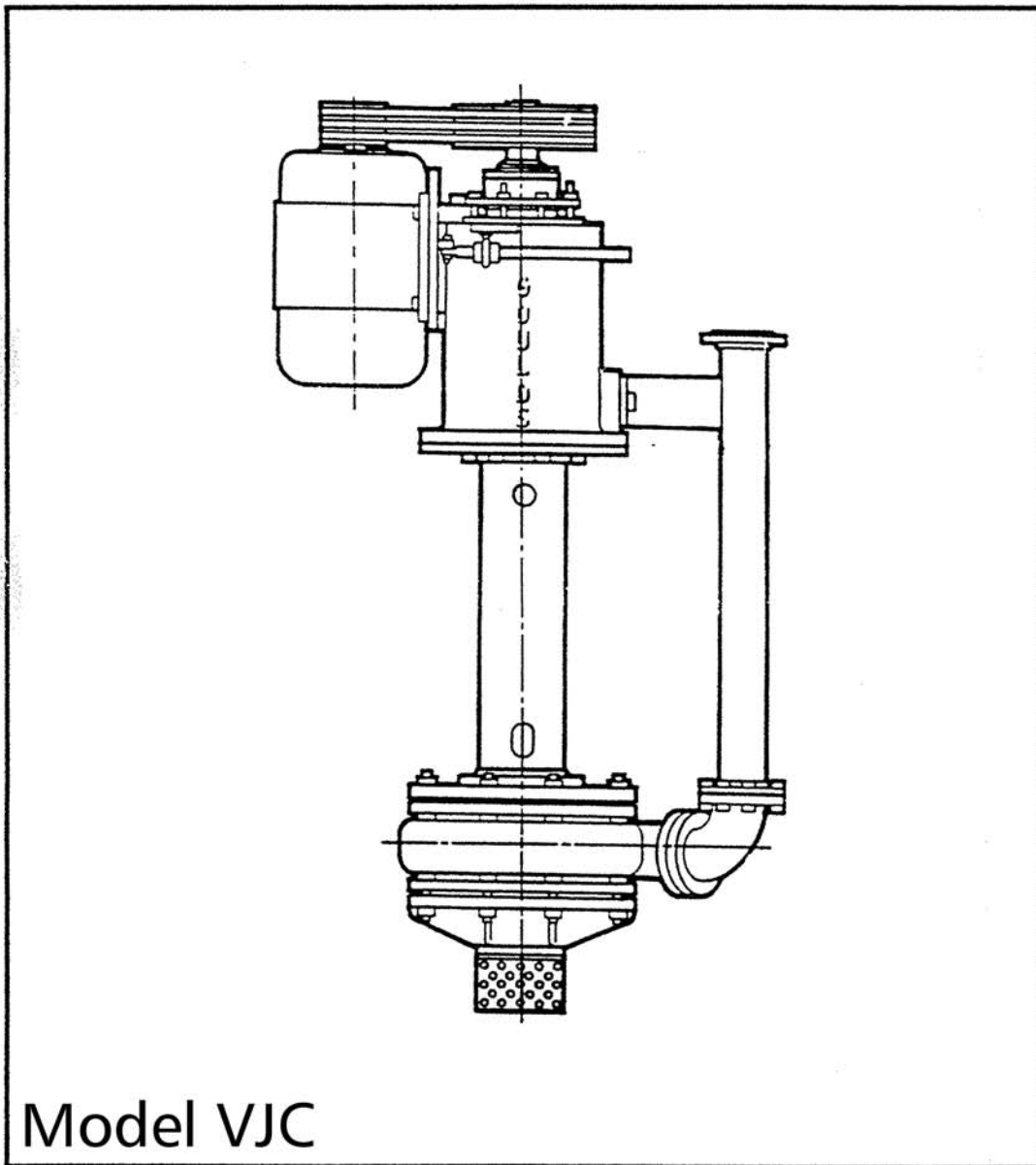

ITT

MODEL VJC INSTALLATION CHECK SHEET

- [] Inspect pump for shipping damage. Note the damage on the receipt and freight bill. Make a claim to transportation company.
- [] Study Installation, Operation and Maintenance Manual (IOM) prior to operation.
- [] Check for free operation of pump shaft. Adjust the impeller if binding is found. Refer to IOM in section IV-C1.
- [] Connect the pump to foundation and piping. Piping must not add any strain to the pump.
- [] Disconnect the coupling or V-belt, and check the rotation of motor. **(Incorrect pump rotation will critically damage pump)**. Reconnect driver.
- [] Attach coupling guard and all other safety devices.
- [] Open the discharge valve to prime the pump. If oil, air, or water leaks from the column pipe or fittings, close the discharge valve and determine the cause of the leak before operation of the pump.
- [] Run the pump at proper speed and hydraulic operating point.

FOREWORD

This manual provides instructions for the Installation, Operation, and Maintenance of the Goulds Model VJC.

The design, materials, and workmanship incorporated in the construction of Goulds pumps makes them capable of giving, trouble-free service. The life and satisfactory service of any mechanical unit, however, is enhanced and extended by correct application, proper installation, periodic inspection, condition monitoring, and careful maintenance. This instruction manual was prepared to assist operators in understanding the construction and the correct methods of installing, operating, and maintaining these pumps.

Goulds shall not be liable for damage or delays caused by a failure to observe the instructions for Installation, Operation, and Maintenance, contained in this manual.

Warranty is valid only when genuine Goulds parts are used.

Use of the equipment on a service other than stated in the order could nullify the warranty, unless written approval is obtained in advance from Goulds Pumps, Inc.

To assure proper installation, supervision from an authorized manufacturer's representative is recommended.

Additional manuals can be obtained by contacting your local Goulds representative.

THIS MANUAL EXPLAINS

Proper Installation
Start-up Procedures
Operation Procedures
Routine Maintenance
Pump Overhaul
Trouble Shooting
Ordering Spares or Repair Parts

IMPORTANT SAFETY NOTICE

To: Our Valued Customers

User safety is a major focus in the design of our products. Following the precautions outlined in this manual will minimize your risk of injury.

ITT Goulds pumps will provide safe, trouble-free service when properly installed, maintained, and operated.

Safe installation, operation, and maintenance of ITT Goulds Pumps equipment are an essential end user responsibility. This *Pump Safety Manual* identifies specific safety risks that must be considered at all times during product life. Understanding and adhering to these safety warnings is mandatory to ensure personnel, property, and/or the environment will not be harmed. Adherence to these warnings alone, however, is not sufficient — it is anticipated that the end user will also comply with industry and corporate safety standards. Identifying and eliminating unsafe installation, operating and maintenance practices is the responsibility of all individuals involved in the installation, operation, and maintenance of industrial equipment.

Please take the time to review and understand the safe installation, operation, and maintenance guidelines outlined in this Pump Safety Manual and the Instruction, Operation, and Maintenance (IOM) manual. Current manuals are available at www.gouldspumps.com/literature_ioms.html or by contacting your nearest Goulds Pumps sales representative.

These manuals must be read and understood before installation and start-up.

For additional information, contact your nearest Goulds Pumps sales representative or visit our Web site at www.gouldspumps.com.

SAFETY WARNINGS

Specific to pumping equipment, significant risks bear reinforcement above and beyond normal safety precautions.

 **WARNING**

A pump is a pressure vessel with rotating parts that can be hazardous. Any pressure vessel can explode, rupture, or discharge its contents if sufficiently over pressurized causing death, personal injury, property damage, and/or damage to the environment. All necessary measures must be taken to ensure over pressurization does not occur.

 **WARNING**

Operation of any pumping system with a blocked suction and discharge must be avoided in all cases. Operation, even for a brief period under these conditions, can cause superheating of enclosed pumpage and result in a violent explosion. All necessary measures must be taken by the end user to ensure this condition is avoided.

 **WARNING**

The pump may handle hazardous and/or toxic fluids. Care must be taken to identify the contents of the pump and eliminate the possibility of exposure, particularly if hazardous and/or toxic. Potential hazards include, but are not limited to, high temperature, flammable, acidic, caustic, explosive, and other risks.

 **WARNING**

Pumping equipment Instruction, Operation, and Maintenance manuals clearly identify accepted methods for disassembling pumping units. These methods must be adhered to. Specifically, applying heat to impellers and/or impeller retaining devices to aid in their removal is strictly forbidden. Trapped liquid can rapidly expand and result in a violent explosion and injury.

ITT Goulds Pumps will not accept responsibility for physical injury, damage, or delays caused by a failure to observe the instructions for installation, operation, and maintenance contained in this Pump Safety Manual or the current IOM available at www.gouldspumps.com/literature.

SAFETY

DEFINITIONS

Throughout this manual the words **WARNING**, **CAUTION**, **ELECTRICAL**, and **ATEX** are used to indicate where special operator attention is required.

Observe all Cautions and Warnings highlighted in this Pump Safety Manual and the IOM provided with your equipment.



WARNING

Indicates a hazardous situation which, if not avoided, could result in death or serious injury.

Example: Pump shall never be operated without coupling guard installed correctly.



CAUTION

Indicates a hazardous situation which, if not avoided, could result in minor or moderate injury.

Example: Throttling flow from the suction side may cause cavitation and pump damage.



ELECTRICAL HAZARD

Indicates the possibility of electrical risks if directions are not followed.

Example: Lock out driver power to prevent electric shock, accidental start-up, and physical injury.









When installed in potentially explosive atmospheres, the instructions that follow the Ex symbol must be followed. Personal injury and/or equipment damage may occur if these instructions are not followed. If there is any question regarding these requirements or if the equipment is to be modified, please contact an ITT Goulds Pumps representative before proceeding.













Example:  Improper impeller adjustment could cause contact between the rotating and stationary parts, resulting in a spark and heat generation.



GENERAL PRECAUTIONS

WARNING

A pump is a pressure vessel with rotating parts that can be hazardous. Hazardous fluids may be contained by the pump including high temperature, flammable, acidic, caustic, explosive, and other risks. Operators and maintenance personnel must realize this and follow safety measures. Personal injuries will result if procedures outlined in this manual are not followed. ITT Goulds Pumps will not accept responsibility for physical injury, damage or delays caused by a failure to observe the instructions in this manual and the IOM provided with your equipment.

General Precautions		
WARNING		NEVER APPLY HEAT TO REMOVE IMPELLER. It may explode due to trapped liquid.
WARNING		NEVER use heat to disassemble pump due to risk of explosion from tapped liquid.
WARNING		NEVER operate pump without coupling guard correctly installed.
WARNING		NEVER run pump below recommended minimum flow when dry, or without prime.
WARNING		ALWAYS lock out power to the driver before performing pump maintenance.
WARNING		NEVER operate pump without safety devices installed.
WARNING		NEVER operate pump with discharge valve closed.
WARNING		NEVER operate pump with suction valve closed.
WARNING		DO NOT change service application without approval of an authorized ITT Goulds Pumps representative.
WARNING		<p>Safety Apparel:</p> <ul style="list-style-type: none"> ♦ Insulated work gloves when handling hot bearings or using bearing heater ♦ Heavy work gloves when handling parts with sharp edges, especially impellers ♦ Safety glasses (with side shields) for eye protection ♦ Steel-toed shoes for foot protection when handling parts, heavy tools, etc. ♦ Other personal protective equipment to protect against hazardous/toxic fluids
WARNING		<p>Receiving:</p> <p>Assembled pumping units and their components are heavy. Failure to properly lift and support equipment can result in serious physical injury and/or equipment damage. Lift equipment only at specifically identified lifting points or as instructed in the current IOM. Current manuals are available at www.gouldspumps.com/literature_ioms.html or from your local ITT Goulds Pumps sales representative. Note: Lifting devices (eyebolts, slings, spreaders, etc.) must be rated, selected, and used for the entire load being lifted.</p>
WARNING		<p>Alignment:</p> <p>Shaft alignment procedures must be followed to prevent catastrophic failure of drive components or unintended contact of rotating parts. Follow coupling manufacturer's coupling installation and operation procedures.</p>

General Precautions		
WARNING		Before beginning any alignment procedure, make sure driver power is locked out. Failure to lock out driver power will result in serious physical injury.
CAUTION		Piping: Never draw piping into place by forcing at the flanged connections of the pump. This may impose dangerous strains on the unit and cause misalignment between pump and driver. Pipe strain will adversely effect the operation of the pump resulting in physical injury and damage to the equipment.
WARNING		Flanged Connections: Use only fasteners of the proper size and material.
WARNING		Replace all corroded fasteners.
WARNING		Ensure all fasteners are properly tightened and there are no missing fasteners.
WARNING		Startup and Operation: When installing in a potentially explosive environment, please ensure that the motor is properly certified.
WARNING		Operating pump in reverse rotation may result in contact of metal parts, heat generation, and breach of containment.
WARNING		Lock out driver power to prevent accidental start-up and physical injury.
WARNING		The impeller clearance setting procedure must be followed. Improperly setting the clearance or not following any of the proper procedures can result in sparks, unexpected heat generation and equipment damage.
WARNING		If using a cartridge mechanical seal, the centering clips must be installed and set screws loosened prior to setting impeller clearance. Failure to do so could result in sparks, heat generation, and mechanical seal damage.
WARNING		The coupling used in an ATEX classified environment must be properly certified and must be constructed from a non-sparking material.
WARNING		Never operate a pump without coupling guard properly installed. Personal injury will occur if pump is run without coupling guard.
WARNING		Make sure to properly lubricate the bearings. Failure to do so may result in excess heat generation, sparks, and / or premature failure.
CAUTION		The mechanical seal used in an ATEX classified environment must be properly certified. Prior to start up, ensure all points of potential leakage of process fluid to the work environment are closed.
CAUTION		Never operate the pump without liquid supplied to mechanical seal. Running a mechanical seal dry, even for a few seconds, can cause seal damage and must be avoided. Physical injury can occur if mechanical seal fails.
WARNING		Never attempt to replace packing until the driver is properly locked out and the coupling spacer is removed.
WARNING		Dynamic seals are not allowed in an ATEX classified environment.
WARNING		DO NOT operate pump below minimum rated flows or with suction and/or discharge valve closed. These conditions may create an explosive hazard due to vaporization of pumpage and can quickly lead to pump failure and physical injury.

General Precautions		
WARNING		Ensure pump is isolated from system and pressure is relieved before disassembling pump, removing plugs, opening vent or drain valves, or disconnecting piping.
WARNING		Shutdown, Disassembly, and Reassembly: Pump components can be heavy. Proper methods of lifting must be employed to avoid physical injury and/or equipment damage. Steel toed shoes must be worn at all times.
WARNING		The pump may handle hazardous and/or toxic fluids. Observe proper decontamination procedures. Proper personal protective equipment should be worn. Precautions must be taken to prevent physical injury. Pumpage must be handled and disposed of in conformance with applicable environmental regulations.
WARNING		Operator must be aware of pumpage and safety precautions to prevent physical injury.
WARNING		Lock out driver power to prevent accidental startup and physical injury.
CAUTION		Allow all system and pump components to cool before handling them to prevent physical injury.
CAUTION		If pump is a Model NM3171, NM3196, 3198, 3298, V3298, SP3298, 4150, 4550, or 3107, there may be a risk of static electric discharge from plastic parts that are not properly grounded. If pumped fluid is non-conductive, pump should be drained and flushed with a conductive fluid under conditions that will not allow for a spark to be released to the atmosphere.
WARNING		Never apply heat to remove an impeller. The use of heat may cause an explosion due to trapped fluid, resulting in severe physical injury and property damage.
CAUTION		Wear heavy work gloves when handling impellers as sharp edges may cause physical injury.
CAUTION		Wear insulated gloves when using a bearing heater. Bearings will get hot and can cause physical injury.

ATEX CONSIDERATIONS and INTENDED USE

Special care must be taken in potentially explosive environments to ensure that the equipment is properly maintained. This includes but is not limited to:

1. Monitoring the pump frame and liquid end temperature.
2. Maintaining proper bearing lubrication.
3. Ensuring that the pump is operated in the intended hydraulic range.

The ATEX conformance is only applicable when the pump unit is operated within its intended use. Operating, installing or maintaining the pump unit in any way that is not covered in the Instruction, Operation, and Maintenance manual (IOM) can cause serious personal injury or damage to the equipment. This includes any modification to the equipment or use of parts not provided by ITT Goulds Pumps. If there is any question regarding the intended use of the equipment, please contact an ITT Goulds representative before proceeding. Current IOMs are available at www.gouldspumps.com/literature_ioms.html or from your local ITT Goulds Pumps Sales representative.

All pumping unit (pump, seal, coupling, motor and pump accessories) certified for use in an ATEX classified environment, are identified by an ATEX tag secured to the pump or the baseplate on which it is mounted. A typical tag would look like this:



The CE and the Ex designate the ATEX compliance. The code directly below these symbols reads as follows:

- II = Group 2
- 2 = Category 2
- G/D = Gas and Dust present
- T4 = Temperature class, can be T1 to T6 (see Table 1)

Code	Max permissible surface temperature °F (°C)	Max permissible liquid temperature °F (°C)
T1	842 (450)	700 (372)
T2	572 (300)	530 (277)
T3	392 (200)	350 (177)
T4	275 (135)	235 (113)
T5	212 (100)	Option not available
T6	185 (85)	Option not available

The code classification marked on the equipment must be in accordance with the specified area where the equipment will be installed. If it is not, do not operate the equipment and contact your ITT Goulds Pumps sales representative before proceeding.

PARTS



The use of genuine Goulds parts will provide the safest and most reliable operation of your pump. ITT Goulds Pumps ISO certification and quality control procedures ensure the parts are manufactured to the highest quality and safety levels.

Please contact your local Goulds representative for details on genuine Goulds parts.

INSTALLATION AND OPERATING INSTRUCTIONS

SAFETY

DEFINITIONS

This pump has been designed for safe and reliable operation. A pump is a pressure containing device with rotating parts that could be hazardous. Operators and maintenance personnel must realize this and follow the necessary safety measures. Goulds Pumps Inc. shall not be liable for damage or delays caused by a failure to observe the instructions in this manual.

Throughout this manual the words **Warning**, **Caution**, and **Note** are used to indicate procedures and situations which require special operator attention:

Warning

Operating procedure, practice, etc. which, if not correctly followed, could result in personal injury or loss of life.

Caution

Operating procedure, practice, etc. which, if not correctly followed, could result in damage or destruction of equipment

NOTE: Operating procedure, condition, etc. which is essential to observe.

Examples:

Warning

Pump shall never be operated without coupling guard correctly installed.

Caution

Never completely restrict the discharge flow. May result in adverse temperature increases and **possibly explosion**.

NOTE: Proper alignment is essential for long pump life.

GENERAL PRECAUTIONS

Warning

Personal injuries will result if procedures outlined in this manual are not followed.

- Never operate pump without coupling guard correctly installed.
- Never operate pump beyond the rated conditions to which the pump was sold.
- Never run pump below the recommended minimum flow or when dry.

- Always lock out power to the driver when performing pump maintenance,
- Never operate pump without safety devices installed.
- Never operate pump with discharge valve closed.
- Never use heat to disassemble pump due to risk of explosion from trapped liquid.
- With the pump disconnected from the driver, check the motor rotation. Incorrect motor rotation can cause the impeller to back off of its threads and rupture the casing. It may also cause personal injury.

**INSTALLATION AND
OPERATING INSTRUCTIONS**

NAMEPLATE INFORMATION

		GOULDS PUMPS, INC.	
SLURRY PUMP DIVISION ASHLAND, PA 17921			
SERIAL NO.	<input type="text"/>		
MODEL	<input type="text"/>		
GPM	<input type="text"/>	FT. HD.	<input type="text"/>
RPM	<input type="text"/>	MAX. ALLOW. PRESS. PSI	<input type="text"/>
		IMPLR. DIA.	<input type="text"/>
SEE INSTRUCTION MANUAL BEFORE OPERATION			
MADE IN U.S.A.			

Figure 1. Goulds Pumps nameplate information.

All VJC pumps carry the same Goulds nameplate, shown in Fig. 1. This nameplate provides information about the pump's hydraulic characteristics.

TABLE OF CONTENTS

SAFETY

NAMEPLATE INFORMATION

SECTION I – GENERAL

Page 1

- I-A Introduction
- I-A Importance of Instructions
- I-B Special Warnings
- I-C Receiving and Inspection – Shortages
- I-D Preservation and Storage

SECTION II – INSTALLATION INSTRUCTIONS – VERTICAL PUMPS

Page 2/3/4/5/6

- II-A Location of Pump
- II-B Pump Support
- II-C Discharge Piping
- II-D Sump
- II-E Direct Connect – Alignment
- II-F V-Belt Drives – Alignment
- II-G Factors That May Disturb Alignment

SECTION III – STARTING A VERTICAL PUMP

Page 7

- III-A Pump Support
- III-B Bearing Lubrication
- III-C Shaft Rotation
- III-D Correct Driver Rotation
- III-E Bearing Housing Seals
- III-F Priming
- III-G Special Warning

SECTION IV – OPERATING AND MAINTENANCE INSTRUCTIONS

Page 8/9

- IV-A Lubrication
- IV-B Seals
- IV-C Maintained Capacity
- IV-D Duplex Thrust Bearing Replacement
- IV-E Gaskets and O-Ring Seals
- IV-F Maintenance Schedule

SECTION V – DISASSEMBLY AND REASSEMBLY

Page 10/11/12/13/14

- V-A Pump Disassembly – Vertical Bottom Suction
- V-B Disassembly of Bearing Housing and Shaft Assembly
- V-C Inspection and Parts Replacement Guidelines
- V-D Reassembly of Bearing Housing and Shaft Assembly
- V-E Pump Reassembly – Vertical Bottom Suction

SECTION VI – SECTION VIEW

Page 15/16/17

SECTION VII – CHECK LIST FOR LOCATING TROUBLE

Page 18

- VII-A Insufficient Capacity
- VII-B Insufficient Pressure
- VII-C Motor Overload
- VII-D Pump Vibration
- VII-E Leak at Column Pipe
- VII-F Water Hammer

SECTION VIII – ORDERING SPARE PARTS

Page 19

- VIII-A Replacement Parts Procedure
- VIII-B Recommended Spare Parts

INSTALLATION AND OPERATING INSTRUCTIONS

SECTION I - GENERAL

INTRODUCTION

This instruction manual is intended to assist those involved with the installation, operation and maintenance of Goulds SPD slurry pumps. It is recommended that this manual be thoroughly reviewed prior to installing or performing any work on the pump or motor.

I-A. IMPORTANCE OF INSTRUCTIONS

The design, material, and workmanship incorporated in the construction of Goulds pumps makes them capable of giving long, trouble-free service. The life and satisfactory service of any mechanical unit, however, is enhanced and extended by periodic inspection and careful maintenance. This Instruction Manual was prepared to assist operators in understanding the construction and correct methods of installing, operating, and maintaining these pumps.

Study thoroughly Sections I, II, III, IV, and carefully follow the instructions for installation and operation. Sections V, VI, VII and VIII are answers to trouble and maintenance questions.

Keep this instruction manual handy for reference. Further information can be obtained by contacting the Slurry Pump Division, East Centre St., Ashland, PA 17921 or your local representative.

I-B. SPECIAL WARNINGS

Goulds' Slurry Pump Division will not be liable for any damages or delay caused by failure to comply with the provisions of this Instruction Manual. This pump is not to be operated at speeds, working pressures, discharge pressures, or temperatures higher than, nor used with liquids other than stated in the original order acknowledgement, without written permission of the Slurry Pump Division, Goulds Pumps, Inc.

I-C. RECEIVING AND INSPECTION - SHORTAGES

Care should be taken when unloading any Goulds' pump. If shipment is not delivered in good order and in accordance with the bill of lading, note the damage and shortage on both the receipt and freight bill. **MAKE ANY CLAIMS TO THE TRANSPORTATION COMPANY PROMPTLY.**

Instruction sheets on various components as well as the Instruction Book for the pump are included in the shipment. **DO NOT DISCARD.**

I-D. PRESERVATION AND STORAGE

Gould's Slurry Pump Division's normal domestic shipping and storage preparation is suitable for protecting the pump during shipment in covered trucks. It also provides protection during covered storage at the jobsite and for a short period between installation and start-up.

One approach is to provide special preservatives and wrapping before shipment. However, after installation, the protective wrappings will have to be removed. Therefore, application of preservatives after installation is considered good practice. Hand rotation of the shaft is recommended every 30 days to prevent damage to the bearings.

If the pump is to be idle and exposed to the elements for an extended period, either before or after installation, special precautions are required. Preservative treatment of bearings and machined surfaces will be required. Also, driver and coupling manufacturers should be contacted for long term storage procedures.

INSTALLATION AND OPERATING INSTRUCTIONS

SECTION II – INSTALLATION INSTRUCTIONS – VERTICAL PUMPS

II-A. LOCATION OF PUMP

The unit should be located in a clean, dry area free from flooding. The area should provide adequate space for maintenance and repair, considering complete disassembly and handling of equipment. The unit should be positioned to provide the most efficient pipeline system.

II-B PUMP SUPPORT

The pump support must be sufficiently substantial and level to give rigid support to the pump and to absorb vibration.

The bolts which secure the pump to the foundation should be 1/8" less in diameter than the holes in the pump frame (size is shown on the certified dimension drawing).

Caution

Provision must be made to support discharge piping independently from the pump to prevent excessive loads and maintain pump-driver alignment.

II-C. DISCHARGE PIPING

Short pipelines and a minimum of elbows and fittings result in the least amount of pipe friction during discharge. Excessive friction losses result in insufficient head.

The pumps are not designed to carry loads imposed by the weight of the pipeline. The pipe must be supported independently near the pump to prevent any strain being transmitted to the pump.

Arrangements should be made to keep the pump from back-spinning severely during shutdown. On a long discharge line, a non-slam check valve should be installed.

II-D. SUMP

The sump must be screened to prevent any foreign objects from falling into the sump and damaging the pump. The openings in the screening should be smaller than the openings in the pump impeller.

II-E. DIRECT CONNECT – ALIGNMENT

Warning

Before beginning any alignment procedure make sure driver power is locked out.

The points at which alignment are checked and adjusted are:

– **Initial Alignment** is done prior to operation when the pump and the driver are at ambient temperature.

– **Final Alignment** is done after operation when the pump and driver are at operating temperature.

NOTE: Proper alignment is the responsibility of the installer and user of the unit.

Accurate alignment of the equipment must be attained. Trouble free operation can be accomplished by following these procedures.

ALIGNMENT CHECKS

Initial Alignment (Cold Alignment)

– Before Mounting Baseplate – To ensure alignment can be attained.

– After Mounting Baseplate – To ensure no changes have occurred during the mounting process.

– After Connecting Piping – To ensure pipe strains haven't altered alignment. If changes have occurred, alter piping to remove pipe strains on pump flanges.

INSTALLATION AND OPERATING INSTRUCTIONS

Final Alignment (Hot Alignment)

- After First Run - To obtain correct alignment when both pump and driver are at operating temperature. Thereafter, alignment should be checked periodically in accordance with plant operating procedures.

ALIGNMENT CRITERIA

Disconnect coupling halves before proceeding with the alignment. Check for parallel and angular alignment with either the Dial Indicator Method or the Straight-Edge Method outlined below.

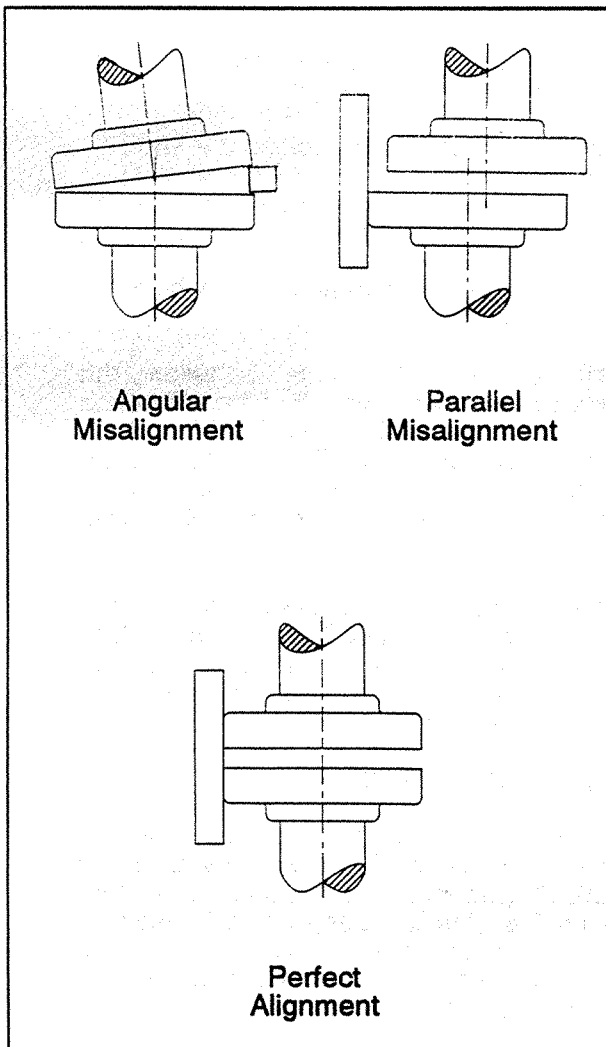

Figure 2. Direct connect alignment

The faces and outside diameters of the coupling halves must be square and concentric with the bores. Good alignment is achieved when the dial indicator readings, for both parallel and angular misalignment, are $.003''$ ($.076mm$) Total Indicated Reading (T.I.R.) or less when the pump and driver are at operating temperature (Final Alignment). Fig. 2 provides a picture of what to look for.

SET UP

1. Mount two dial indicators on one of the coupling halves (X) so that they contact the other coupling half (Y), see Fig. 3.

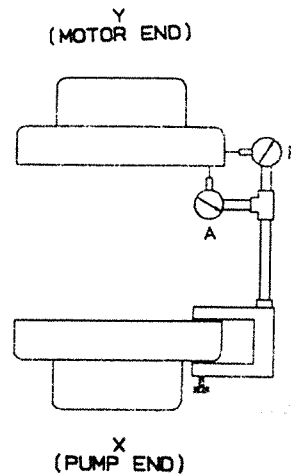

Figure 3. Dial indicator set up.

2. Check setting of indicators by rotating coupling half X to ensure indicators stay in contact with coupling half Y but do not bottom out. Adjust indicators accordingly.

MEASUREMENT TECHNIQUES

1. To ensure accuracy of indicator readings, always rotate both coupling halves together so indicators contact the same point on coupling half Y. This will eliminate any measurement problems due to runout on coupling half Y.
2. Take indicator measurements with driver hold-down bolts tightened. Loosen hold-down bolts prior to making alignment corrections.
3. Take care not to damage indicators when moving driver during alignment corrections.

INSTALLATION AND OPERATING INSTRUCTIONS

Alignment Procedure

A check for both angular and parallel alignment must be completed and the necessary adjustments be made to obtain the .003" (.076mm) T.I.R. stated in the alignment criteria.

ANGULAR ALIGNMENT

A unit is in angular alignment when indicator A (Angular Indicator), Fig 3 page 3, does not vary by more than .003" (.076mm) as measured at four points on the coupling periphery 90° apart at operating temperature. There are two methods outlined below which are acceptable to achieve the desired alignment.

METHOD 1 - Dial Indicator Method

For the following steps, refer to Fig. 4.

1. Zero indicator A at position 1 of coupling half Y. Mark this position on both flanges.
2. Rotate both flanges 180° to position 3. Observe needle and record reading.
3. Negative Reading - The coupling halves are further apart at position 3 than position 1.

Positive Reading - The coupling halves are closer at position 1 than position 3.

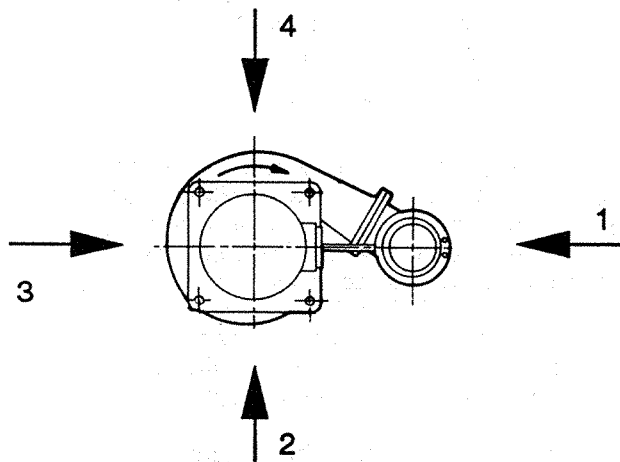

Figure 4. Directions of viewing coupling.
View from top of pump.

4. The angular alignment should not be a problem. If, however, .003" (.076mm) T.I.R. or less is not attainable check the motor and motor mount for perpendicularity to their respective centerlines.

5. Repeat steps 1-4 substituting position 2 for position 1 and position 4 for position 3. Use the same marks made on the coupling from positions 1 and be sure to turn the coupling halves together.

METHOD 2 - Feeler Gauge Method

For the following steps refer to Fig. 4.

1. Insert a feeler gauge at position 1 at the periphery of the couplings. Mark this position on both flanges.
2. Record the largest gauge size which fits snugly between the two flanges.
3. Rotate both flanges to position 3 - 180°.
4. Insert a feeler gauge at position 3 at the periphery of the couplings.
5. Record the largest gauge size which fits snugly between the two flanges.
6. Calculate the difference between the readings at positions 1 and 3. The difference should not be greater than .003" (.076mm). If, however, .003" (.076mm) T.I.R. or less is not attainable check the motor and motor mount for perpendicularity to their respective centerlines.

7. Repeat steps 1-6 substituting positions 2 and 4 for positions 1 and 3 respectively. Use the same marks made on the coupling from position 1 and be sure to turn the coupling halves together.

PARALLEL ALIGNMENT

The unit is in parallel alignment when indicator P (Parallel Indicator) does not vary by more than .003" (.076mm) as measured at four points on the coupling periphery 90° apart at operating temperature. There are two methods outlined below which are acceptable to achieve the desired alignment.

INSTALLATION AND OPERATING INSTRUCTIONS

METHOD 1 – Dial Indicator Method

For the following steps, refer to Fig. 4.

1. Zero indicator P at position 1 of coupling half Y. Mark this position on both flanges.

2. Rotate both flanges 180° to position 3. Observe needle and record reading.

3. Negative Reading – The coupling half Y is shifted toward position 1. If the value is greater than .003" (.076mm), shift the motor accordingly.

Positive Reading – The coupling half Y is shifted toward position 3. If the value is greater than .003" (.076mm), shift the motor accordingly.

4. Repeat steps 1–3 until indicator P reads .003" (.076mm) or less.

5. Once the ideal alignment is reached, repeat steps 1–4 substituting position 2 for position 1 and position 4 for position 3.

METHOD 2 – Straight-Edge Method

For the following steps refer to Fig. 4.

1. Place a straight edge across the two coupling flanges at position 1 and mark the spot on both flanges.

2. Adjust the motor so that the straight-edge rests evenly on both flanges (within .003" – .076mm).

3. Rotate both flanges 90° to positions 2 and repeat steps one and two.

4. The unit will be in parallel alignment when the straight edge rests evenly (within .003" – .076mm) on the coupling periphery at both positions along the periphery.

NOTE: Care must be taken to have the straight edge parallel to the axis of the shafts.

TIP: Since the coupling halves are disconnected, this would be a good time to check the motor rotation to see if it is in the proper direction.

II-F. V-BELT DRIVE – ALIGNMENT

Well designed and properly installed v-belt drives are capable of running for years without maintenance. There are a few points that should be checked periodically.

1. Sheave Alignment – Alignment must be maintained for full power transmission, minimum vibration, and long drive life. A dial indicator can be used to check runout on the periphery and face of each sheave. A straight edge can be used to check the alignment of the pump and drive sheaves in the vertical direction. See Fig. 6 page 6.

2. Belt Installation – When installing new belts, shorten center distance between sheaves so that belts can be placed on the sheave without the use of force. Never "roll" or "pry" the belts into place, as this could damage the belt cords.

3. Check Belt Fit – Regardless of the belt section used, the belt should never be allowed to bottom in the groove. This will cause the belts to lose their wedging action and slippage can occur. Sheaves or belts that permit such a condition to occur should be changed.

4. Maintain Proper Belt Tension – Proper tension is essential for long belt life. Improper tension could cause belt fatigue and/or hot bearings.

The general method for tensioning belts is given below, and should satisfy most drive requirements.

Step 1: Reduce the center distance so that the belts may be placed over the sheaves and in the grooves without forcing them over the sides of the grooves. Arrange the belts so that both belt spans have approximately the same sag between the sheaves. Apply tension to the belts by

INSTALLATION AND OPERATING INSTRUCTIONS

increasing the center distance until the belts are snug, see Fig.5.

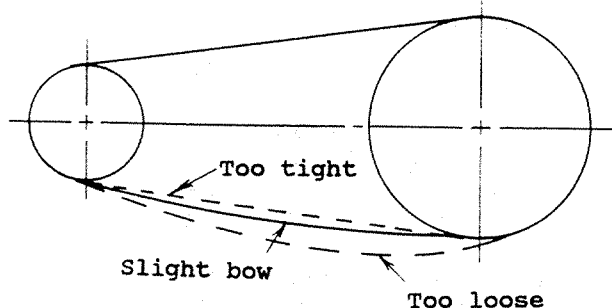

Figure 5. V-belt tension positions.

Step 2: Operate the drive a few minutes to seat the belts in the sheave grooves. Observe the operation of the drive under its highest load condition (usually starting). A slight bowing of the slack side of the drive indicates proper tension. If the slack side remains taut during the peak load, the drive is too tight. Excessive bowing or slippage indicates insufficient tension. If the belts squeal as the motor begins operation or at some subsequent peak load, they are not tight enough to deliver the torque demanded by the drive machine. The drive should be stopped and the belts tightened.

Step 3: Check the tension on a new drive frequently during the first day by observing the slack side span. After a few days of operation the belts will seat themselves in the sheave grooves and it may become necessary to readjust so that the drive again shows a slight bow in the slack side.

Other methods of determining proper belt tension can be obtained from the drive manufacturer.

5. Use Belt Guards - Belt guards protect personnel from danger and the drive from contamination. Inspect periodically to assure that belts do not rub against guard.

Warning

Do not operate the pump without the proper drive guard in place. Failure to observe this

warning could result in personal injury to operating personnel.

6. Keep Belts Clean - Dirt and grease reduce belt life. Belt dressing affects performance only temporarily and is never recommended. Maintaining a clean drive is a better idea.

If any questions arise pertaining to the drive limitations, consult the manufacturer.

II-G. FACTORS THAT MAY DISTURB ALIGNMENT

Caution

The unit should be checked periodically for alignment. If the unit does not stay in line after being properly installed, the following are possible causes:

1. Settling or spring of the foundation.
2. Wear of bearings.
3. Pipe strains distorting or shifting the machine.
4. Spring of the base plate due to heat created from an adjacent heat source.
5. Shifting of the building structure due to variable loading or other causes.
6. Loose nuts or bolts on the pump or driver assembly.

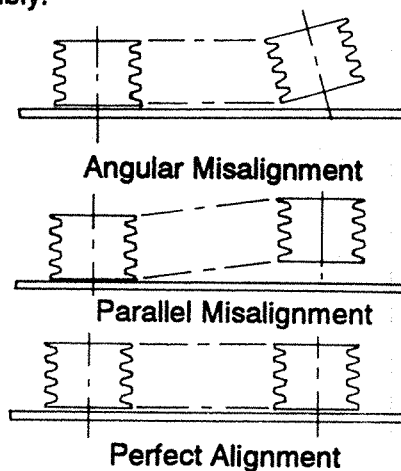

Figure 6. V-belt drive alignment

INSTALLATION AND OPERATING INSTRUCTIONS

SECTION III - STARTING A VERTICAL PUMP

III-A. PUMP SUPPORT - Before starting a new pump, check the pump supports and piping to be certain that they conform to the specifications in the "Installation Instructions" section.

III-B. BEARING LUBRICATION - The bearing housing must have adequate lubrication. The bearing housing is properly filled with grease before shipment. Under normal conditions relubricate monthly or after 500 hours of operation, whichever occurs first. See Lubrication Section IV-A for grease type and amount.

III-C. SHAFT ROTATION - The pump shaft must turn without any binding or rubbing. By manually turning the rotating element, only the uniform frictional drag of the bearings should be felt. If the pump does not turn freely, it should be checked to determine the cause of binding.

III-D. CORRECT DRIVER ROTATION - The direction of rotation of the driver must be checked before it can be coupled with the pump. The direction of rotation of the pump is indicated in a prominent location. For pumps with impellers threaded on the shaft, reverse rotation would back the shaft from the impeller thread.

Warning

Incorrect rotation could result in considerable damage to the pump.

Warnings

THIS UNIT MUST NEVER BE USED WITHOUT PRIOR INSTALLATION OF THE SAFETY GUARDS FOR ROTATING PARTS AS PRESCRIBED BY O.S.H.A.

OPERATION OF THIS PUMP WITH THE DISCHARGE VALVE CLOSED FOR EVEN BRIEF PERIODS OF TIME IS AN UNACCEPTABLE AND DANGEROUS PRACTICE. A GREAT DANGER EXISTS FROM POSSIBLE EXPLOSION!

DO NOT APPLY HEAT TO THE HUB OR NOSE OF THREADED IMPELLER. DANGER OF EXPLOSION

Warning

Lockout power to the driver before checking the motor rotation

III-E. BEARING HOUSING SEALS - The bearing housing seals may generate some heat until broken in. Oil may be applied to them if the heat becomes excessive at the time the pump is started.

III-F. PRIMING - The pump must be completely primed before operation. The pump must not be started unless the liquid level is above the impeller.

III-G. SPECIAL WARNING - At the shutoff point, with no water flow, the horsepower delivered to the pump is rapidly converted into heat. **A GREAT DANGER EXISTS FROM POSSIBLE EXPLOSION!** Use the check sheet to prepare the pump for operation.

Caution

Immediately observe pressure changes. If the discharge pressure is not quickly attained - stop the driver, reprime and attempt to restart.

INSTALLATION AND OPERATING INSTRUCTIONS

SECTION IV – OPERATING AND MAINTENANCE INSTRUCTIONS

IV-A. LUBRICATION

Warning

OPERATION OF THE PUMP WITHOUT PROPER LUBRICATION CAN RESULT IN OVERHEATING OF THE BEARINGS, BEARING FAILURES, PUMP SEIZURES AND ACTUAL BREAKUP OF THE EQUIPMENT EXPOSING OPERATING PERSONNEL TO POSSIBLE INJURY.

The bearing housing is properly filled with grease before shipment. Under normal conditions, grease should be added monthly, or after 500 operating hours, whichever occurs first. Add .40 ounces to the inboard fitting and .80 ounces to the outboard fitting.

Use

Shell	Alvania No. 2
Mobil	Mobilux EP No. 2
Texaco	Multifak No. 2
Sun Oil Company	Prestige No. 42
American Oil Company	Amolith Grease No. 2

or equal.

When it becomes necessary to replace the bearing housing seals, the housing and the bearings should be flushed clean with a solvent and repacked with new grease. Over-lubrication results in excessive bearing temperatures.

IV-B. SEALS

The upper bearing housing seal may generate some heat until broken in. Oil may be applied to the seal if the heat it generates becomes excessive at the time the pump is started. Make sure the seal area is free of dust and dirt prior to starting.

IV-C. MAINTAINED CAPACITY

The amount of liquid being pumped will lessen as wear occurs between the faces of the

impeller and suction liner. To maintain full pump capacity, the impeller clearance must be adjusted periodically. Each application is different and it is necessary to determine the amount of wear for a certain time period before setting up a schedule for adjustment.

1. Impeller Clearance Adjustment

(a) Shut the discharge valve to the pump.

(b) Loosen the thrust bearing housing locking stud nuts (370C). (Refer to Fig 8 page 11)

(c) Turn impeller clearance adjusting bolts (370D/ccw) to move the bearing housing down until the impeller (101) touches the suction liner (100B). Turn the bolts to raise the bearing housing .06", which gives the recommended operating clearance. Make sure the impeller turns freely through the entire rotation.

(d) Tighten thrust bearing housing locking stud nuts and bolts (370C).

2. Conditions Requiring Adjustments

(a) Overheated thrust bearings may develop from uneven adjustment of the jam nuts. Check lubrication.

(b) Noise, vibration and wear may result from the impeller rubbing on the suction liner or casing wall. Adjust impeller clearance.

(c) Poor performance and wear may result from excessive impeller clearance at the suction side casing liner.

NOTE: Lubricate adjusting studs for easy maintenance.

IV-D. DUPLEX THRUST BEARING REPLACEMENT

Duplex bearings are made up of two single row bearings manufactured with controlled relationship between the axial location of the inner and outer ring faces and are supplied as matched pairs or sets.

INSTALLATION AND OPERATING INSTRUCTIONS

When it becomes necessary to replace a duplex bearing, both halves of the new bearing must be matched. Under no circumstances should a duplex bearing be made by using two single row bearings not specifically matched for duplex use.

When replacing a duplex bearing, mount the two mated bearings back-to-back so that the stamped faces (high shoulders) of the outer rings are together.

In case of making replacements for bearings which have been installed and run, it is recommended that both halves be replaced. This avoids the dangers involved in attempting to match two bearings, one of which has unknown internal characteristics.

IV-E. GASKETS AND O-RING SEALS

When making inspections or repairs, be sure to replace all gaskets and o-rings. Pumps will operate at reduced capacities if o-rings are not installed.

IV-F. MAINTENANCE SCHEDULE

In general, a routine maintenance program can extend the life of your pump. Well maintained equipment will last longer and require fewer repairs.

TIP: You should keep maintenance records, this will help pinpoint potential causes of problems.

1. Routine Maintenance -
 - Bearing lubrication
 - Seal monitoring
 - Vibration analysis
 - Discharge pressure
 - Temperature monitoring
 2. Routine Inspections -
 - Check for unusual noise, vibration and bearing temperatures.
 - Inspect pump and piping for leaks.
 3. Quarterly Inspections -
 - Check hold down bolts for tightness.
 4. Yearly Inspections -
 - Check pump capacity, pressure and power.
- If the pump performance does not satisfy your process requirements, the pump should be disassembled and inspected. Worn parts should be replaced.

INSTALLATION AND OPERATING INSTRUCTIONS

SECTION V - DISASSEMBLY AND REASSEMBLY

Warning

**DO NOT APPLY HEAT TO THE HUB OR NOSE OF A THREADED IMPELLER.
DANGER OF EXPLOSION.**

V-A. DISASSEMBLY OF A BOTTOM SUCTION PUMP - VJC

1. Lock out power supply to motor.
2. Shut off valves controlling flow from the pump. Remove all auxiliary piping and tubing.
3. Remove pump.
4. Loosen v-belts or disconnect coupling. Remove either from shaft.
5. Remove motor and motor mount if a direct connected pump.
6. Unbolt and remove suction cover (182) and suction cover liner (100B).
7. With the shaft (122) clamped, turn the impeller (101) in the direction of normal rotation and unscrew from the shaft. To avoid damage to shaft, wrap tape around threads.
8. Unbolt studs, nuts and bolts (370 & 371H). Remove casing (100) with rubber gasket (211).
9. Unbolt nuts (370H) from throttle bushing (473) and remove from column pipe. Access to nuts is made through column pipe relief holes.
10. Slide shaft sleeve (126) from shaft (122).
11. Disassemble column pipe (192) and discharge pipe (195).
12. Remove nuts from bearing housing locking studs (370C). See Fig. 8 page 11.
13. Draw bearing housing and shaft assembly from the frame (228).

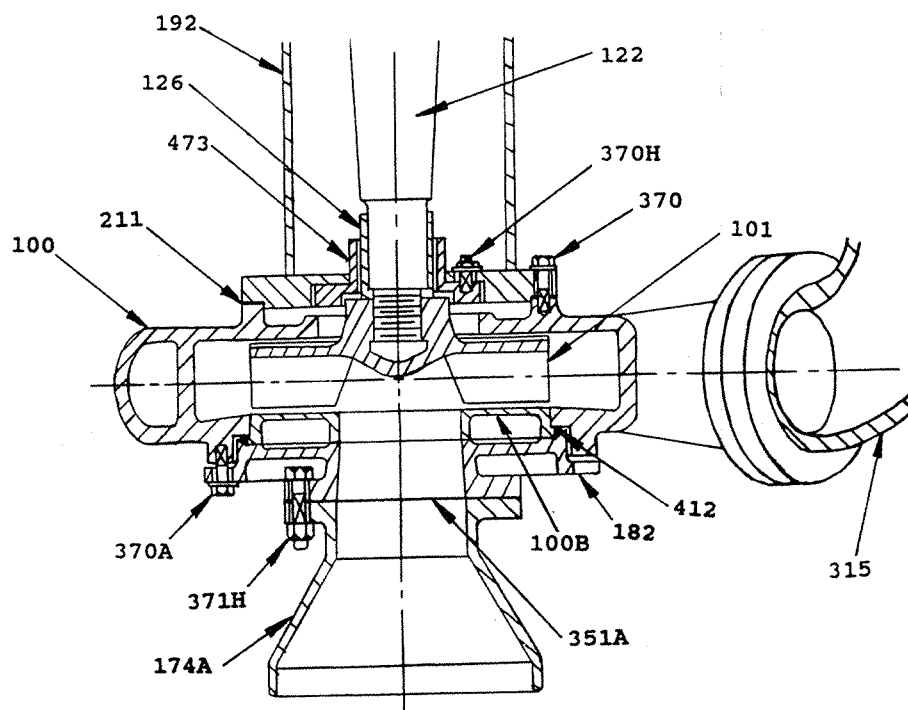

Figure 7. VJC suction end.

INSTALLATION AND OPERATING INSTRUCTIONS

V-C INSPECTION AND PARTS REPLACEMENT GUIDELINES

1. Impeller -- Replace if impeller shows excessive erosion, corrosion, extreme wear or vane breakage. Hubs must be in good condition. Reduction in hydraulic performance may be caused by excessive impeller wear, especially along the suction liner mating surface. Replace if impeller adjustment is gone.
2. Suction Liner -- Replace if impeller mating surface is worn flush.
3. Shaft Sleeve -- Sleeve surface and throttle bushing must be smooth. If either are badly grooved or cut it must be replaced.
4. Casing - Suction Cover -- Replace if worn.
5. Shaft -- Check for runout (.006" max.) to see that shaft has not been bent. Bearing seats and oil seal area must be smooth and free of scratches or grooves. Shaft threads must be in good condition. Replace if necessary.
6. Bearings -- Replace if worn, loose, or rough and noisy when rotated.
7. Oil Seals, O-Rings, and Gaskets -- Replace.
8. General -- All parts must be clean before assembly. All burrs should be removed.

NOTE: STANDARD BEARING MANUFACTURER FITS AND TOLERANCE DIMENSIONS ARE USED IN THE MANUFACTURE OF SPD VERTICAL PUMPS.

Warning

Do not apply heat to hub or nose of threaded impeller. Danger of explosion.

INSTALLATION AND OPERATING INSTRUCTIONS

V-D. REASSEMBLY OF BEARING HOUSING AND SHAFT ASSEMBLY

1. Clean shaft (122) thoroughly, checking for nicks or worn areas. Refer to Fig. 8 page 11.
2. Press outboard seal (332) into outboard end cover (109), positioning the seal so that the lip points upward when installed with the pump. Press inboard seal (333) into frame (228) with the lip pointing downward and secure with capscrews (370P).
3. Heat outboard bearings evenly using an oven, hot clean oil bath or other approved method. The use of a torch is not recommended. Heat to 230 to 250° F. Slide each bearing onto the shaft so that the wide side of the outer rings are together. Hold each bearing inner ring down toward the shaft shoulder. Allow the bearings to cool. Place a sleeve over the shaft and drive both inner rings together toward the shaft shoulder.
4. Position outboard bearing locknut (136) and lockwasher (382) against the bearing shoulder and tighten firmly only after the bearings are cool. Bend "tang" of lockwasher into slot in locknut after the nut has been tightened.
5. Hand pack outboard bearing with recommended grease (see Section IV-A). Mound a small amount of grease above the bearing to insure sufficient lubrication. Bearing cavity should be half filled with grease and then rotated to distribute.
6. Insert bearing housing (134A) over the impeller end of shaft and pull over outboard bearing. Attach end cover (109) with o-ring (496). Tighten bolts evenly so outboard bearing seats properly. A gap of approximately .06" should exist between the end cover flange and the bearing housing. This gap assures the bearing is tight into the bearing housing.
7. Press inboard bearing (168C) onto shaft until inner race seats onto shaft shoulder.
8. Hand pack inboard bearing fully with recommended grease (see Section IV-A). Mound a small amount of grease above bearing to insure sufficient lubrication.

INSTALLATION AND OPERATING INSTRUCTIONS

V-E. PUMP REASSEMBLY -- VERTICAL BOTTOM SUCTION - VJC

1. Install o-ring (496A) onto bearing housing (134A).
2. Insert bearing housing and shaft assembly into frame (228).
3. Reassemble column pipe (192), frame (228), discharge pipe (195), casing (100), discharge elbow (315), and throttle bushing (473) as required.
4. Position bearing housing shaft assembly so that the shaft is as far into the water end as possible. This will assure proper placement of the impeller (101) on the shaft.
5. Install nuts on bearing housing locking studs (370C).
6. Slide shaft sleeve (126) onto shaft after coating shaft with an anti-seizing compound such as "Never Seez" or equal.
7. Remove protective tape from shaft threads.
8. Thread impeller (101) onto shaft (122). Make sure impeller contacts shaft sleeve (126).
9. Rotate shaft to assure that all parts are free.
10. Move impeller (101) by means of the impeller adjusting bolts toward the throttle bushing (473) as far as possible.
11. Attach suction liner (100B) to the suction cover (182). Apply a small amount of "Never Seez" in casing fit to facilitate removal.
12. Place o-ring on suction cover (182). Position suction cover and suction liner assembly into casing (100) and bolt it in place. Tighten all bolts evenly so that suction cover will not become misaligned.
13. Adjust impeller (101) using the adjusting bolts so that it rubs the suction liner (100B). Back off impeller approximately .06", the recommended operating clearance. Do not cock the bearing housing (134A). Make sure the impeller turns freely through the entire rotation. Lock adjusting bolts in place.
14. Tighten bearing housing locking studs (370C).
15. Attach motor mount if direct connected pump.
16. Connect v-belt drive or coupling.
17. Follow procedure for installation of vertical pumps.

INSTALLATION AND OPERATING INSTRUCTIONS

SECTION VI-A - VJC SECTION DRAWING

Pumps manufactured with bearing assemblies C1- C4, C5A, & C6A use ball bearings.

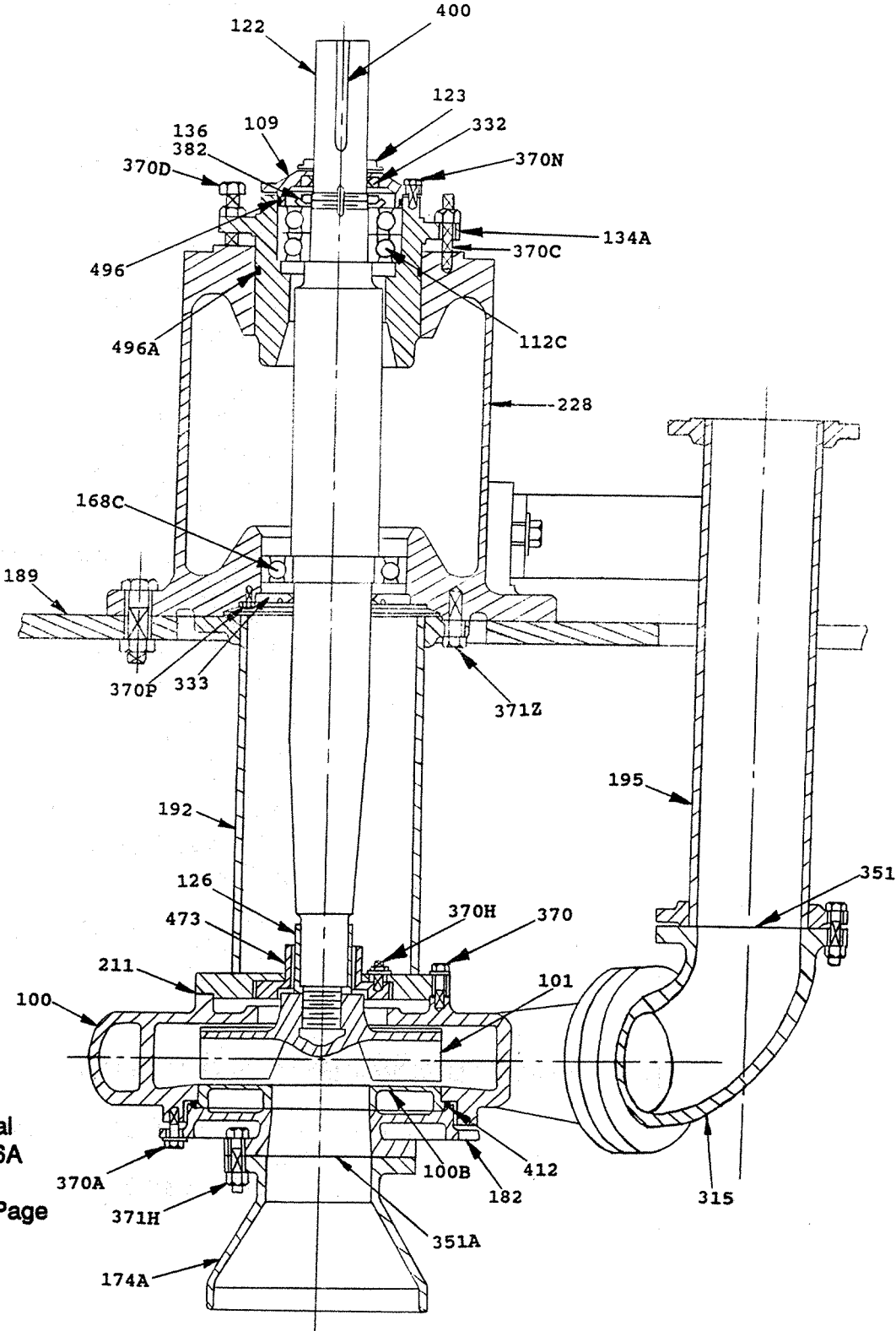

Figure 9. VJC full sectional C1-C4, C5A, C6A bearing frames.
B.O.M. - See next Page

INSTALLATION AND OPERATING INSTRUCTIONS

SECTION VI-A (CONT'D) - VJC SECTION DRAWING

ITEM	QTY.	PART NAME
100	1	CASING
100B	1	SUCTION LINER
101	1	IMPELLER
109	1	END COVER
112C	1	THRUST BEARING
122	1	SHAFT
123	1	DEFLECTOR
126	1	SHAFT SLEEVE
134A	1	BRG. HOUSING
136	1	BRG. LOCKNUT
168C	1	RADIAL BEARING
174A	1	SUCTION BELL**
182	1	SUCTION COVER
189	1	FLOORPLATE**
192	1	COLUMN PIPE ASSY
195	1	DISCHARGE PIPE ASSY
211	1	GASKET
228	1	FRAME
315	1	DISCHARGE ELBOW
332	1	GREASE SEAL
333	1	GREASE SEAL
351	2	GASKET
351A	1	GASKET
382	1	BRG. LOCKWASHER
400	1	KEY COUPLING
412	1	O-RING
473	1	THROTTLE BUSHING
496	1	O-RING
496A	1	O-RING

HARDWARE BELOW FRAME* FRAME HARDWARE

* Threaded hardware below the frame is coated with loctite 242, or equal.

** Floorplate and suction bell are optional

INSTALLATION AND OPERATING INSTRUCTIONS

SECTION VI-B - VJC SECTION DRAWING C5 & C6 BEARING ASSEMBLIES

NOTE: Consult page 1 of pump bill of material for bearing size used in your pumps.

Pumps manufactured with bearing assemblies C5 & C6 use spherical roller bearings (item 168C) and tapered roller bearings (item 112C).

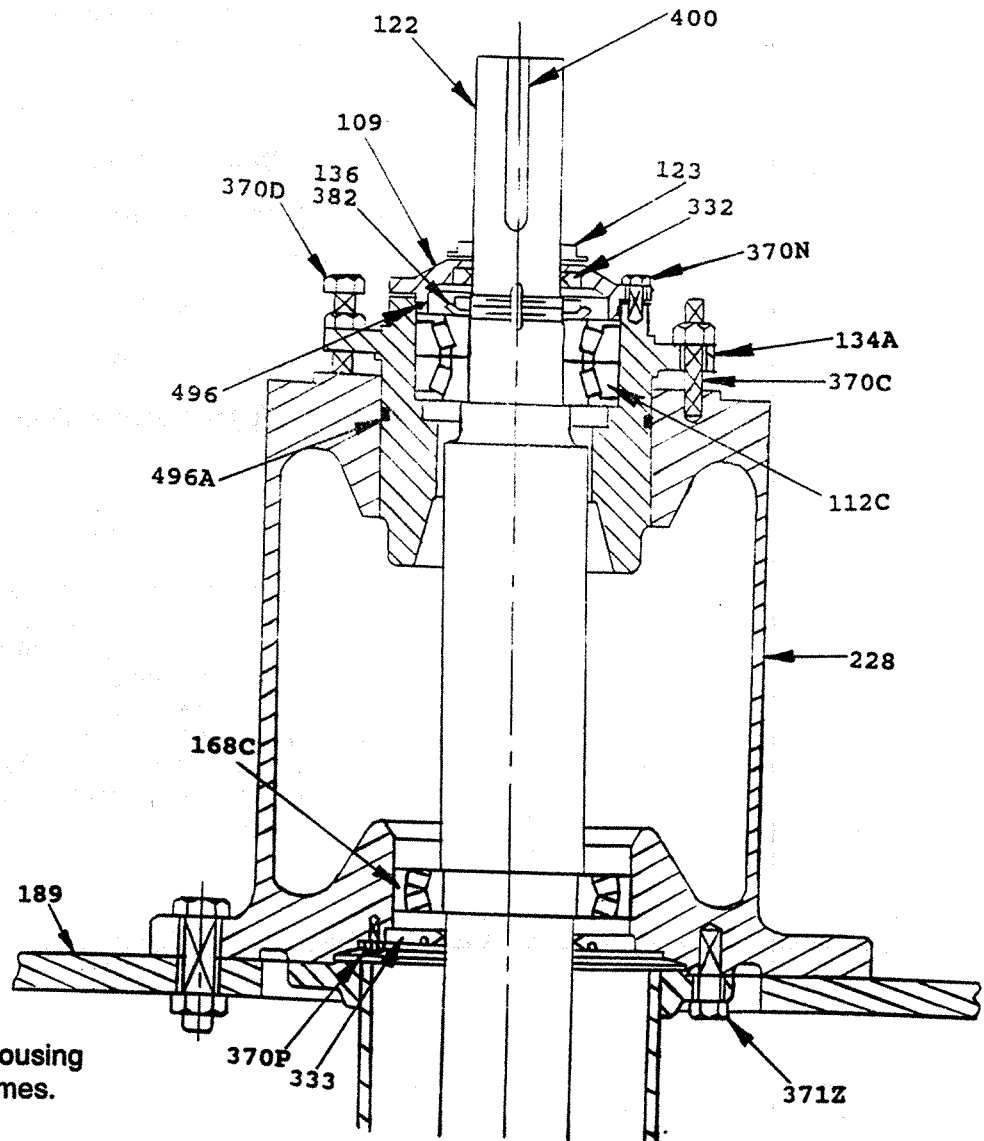

Figure 10. VJC bearing housing
C5 and C6 frames.

INSTALLATION AND OPERATING INSTRUCTIONS

SECTION VII – CHECK LIST FOR LOCATING TROUBLE

VII-A. INSUFFICIENT CAPACITY

1. Pump not primed, insure sump level is above casing.
2. Speed too low.
3. Total head higher than pump rating.
4. Suction lift too great or insufficient NPSH of system.
5. Impeller passages partially blocked.
6. Suction line partially blocked.
7. Wrong direction of rotation.
8. Mechanical defects: impeller worn or damaged; defective gasket causing leakage.

VII-B. INSUFFICIENT PRESSURE

1. Speed too low.
2. Air in slurry.
3. Wrong direction of rotation.
4. Mechanical defects: impeller worn or damaged; defective gasket causing leakage.

VII-C. MOTOR OVERLOAD

1. Speed too high.
2. Total head lower than pump rating (pump will attempt to pump too much water).
3. Slurry being pumped has higher specific gravity than that for which pump is rated.
4. Mechanical defects: shaft bent; worn bearings; worn impeller or other water end parts.
5. Slurry locked in and around impeller.
6. Pump running at high horsepower area of the pump curve (off of design point).

7. Rubbing or binding of rotating elements.

VII-D. PUMP VIBRATION

1. Foundation not sufficiently rigid.
2. Impeller partially blocked causing unbalance.
3. Misalignment.
4. Mechanical defects: shaft bent, worn bearings, impeller worn.

VII-E. LEAK AT COLUMN PIPE

1. Worn impeller.
2. Discharge pressure greater than pump rating.
3. Worn bearings.
4. Speed too low.
5. Deteriorated o-rings or gaskets.
6. Poor pipe joints.

VII-F. WATER HAMMER

Water hammer is a high pressure surge within a closed pipe system, created by a rapid change in the flow rate. Changes in the flow rate occur when there are sudden changes in the pump speed. The most common cause is the sudden opening or closing of a valve or flow control device. Extensive damage to the pump and pipeline is a result of water hammer.

INSTALLATION AND OPERATING INSTRUCTIONS

SECTION VIII -ORDERING SPARE PARTS

VIII-A. REPLACEMENT PARTS PROCEDURE

To insure against possible long and costly down time periods, especially on critical services, it is advisable to have spare parts on hand.

Repair orders will be handled with a minimum of delay if the following directions are followed:

1. Give model number, size of pump, and serial number. These can be obtained from the nameplate on the pump.
2. Write plainly the name and part number of each part required. These names and numbers should agree with those on the bill of material.
3. Give the number of parts required.
4. Give complete shipping instructions.

VIII-B. RECOMMENDED SPARE PARTS

The following are pump application categories and their recommended spare parts.

Light Duty - Random mildly abrasive particles:
1 Shaft Sleeve
1 Gasket Set

Medium Duty - Light slurries up to 1.2 S.G. with moderately abrasive materials:
1 Impeller
1 Set Liners
1 Shaft Sleeve
1 Gasket Set
1 Set Bearings

Heavy Duty - Slurries over 1.2 S.G. with highly abrasive materials:

1 Casing
1 Impeller
2 Sets Liners
1 Bearing Assembly
2 Shaft Sleeves
3 Gasket Sets

Severe Duty - Key process equipment on heavy slurries over 1.2 S.G. with high heads and highly abrasive particles:

1 Casing
2 Impellers
2 Sets Liners
2 Shaft Sleeves
3 Gasket Sets
1 Spare Pump

HOW TO ORDER

When ordering parts call
1-800-446-8537
or your local Goulds Representative

EMERGENCY SERVICE

Emergency parts service is available
24 hours/day, 365 days/year...
Call **1-800-446-8537**

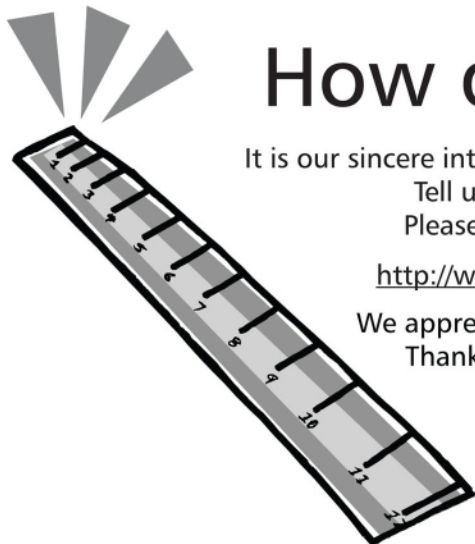

How did we measure up?

It is our sincere intention to exceed our customer's expectations on every order.

Tell us whether we achieved our goal on your order.

Please take our customer satisfaction survey online at:

<http://www.ittindustrialproducts.com/feedbacksurvey.html>

We appreciate you taking the time to provide your feedback.

Thank you for buying ITT pumps, parts, and controls.

Visit our website at www.gouldspumps.com

