

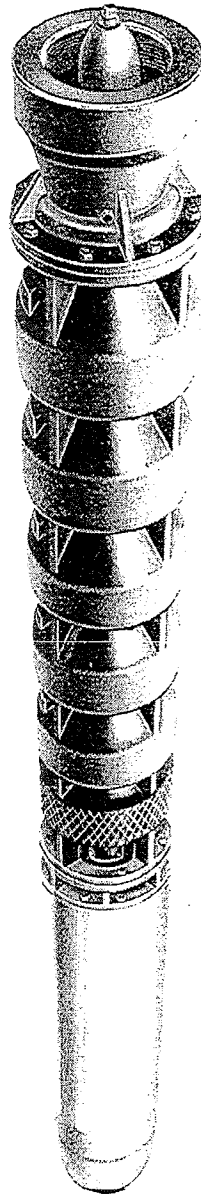

Installation, Operation and Maintenance Instructions



MODEL VIS

CAUTION

The information in this manual is intended to be used as a guide only. If you are in doubt, consult the factory at (562) 949-2113 for specific information about your pump. See the pump nameplate and/or your pump outline drawing for the correct impeller lift setting.



ITT

IMPORTANT SAFETY NOTICE

To: Our Valued Customers

User safety is a major focus in the design of our products. Following the precautions outlined in this manual will minimize your risk of injury.

ITT Goulds pumps will provide safe, trouble-free service when properly installed, maintained, and operated.

Safe installation, operation, and maintenance of ITT Goulds Pumps equipment are an essential end user responsibility. This *Pump Safety Manual* identifies specific safety risks that must be considered at all times during product life. Understanding and adhering to these safety warnings is mandatory to ensure personnel, property, and/or the environment will not be harmed. Adherence to these warnings alone, however, is not sufficient — it is anticipated that the end user will also comply with industry and corporate safety standards. Identifying and eliminating unsafe installation, operating and maintenance practices is the responsibility of all individuals involved in the installation, operation, and maintenance of industrial equipment.

Please take the time to review and understand the safe installation, operation, and maintenance guidelines outlined in this Pump Safety Manual and the Instruction, Operation, and Maintenance (IOM) manual. Current manuals are available at www.gouldspumps.com/literature_ioms.html or by contacting your nearest Goulds Pumps sales representative.

These manuals must be read and understood before installation and start-up.

For additional information, contact your nearest Goulds Pumps sales representative or visit our Web site at www.gouldspumps.com.

SAFETY WARNINGS

Specific to pumping equipment, significant risks bear reinforcement above and beyond normal safety precautions.

 **WARNING**

A pump is a pressure vessel with rotating parts that can be hazardous. Any pressure vessel can explode, rupture, or discharge its contents if sufficiently over pressurized causing death, personal injury, property damage, and/or damage to the environment. All necessary measures must be taken to ensure over pressurization does not occur.

 **WARNING**

Operation of any pumping system with a blocked suction and discharge must be avoided in all cases. Operation, even for a brief period under these conditions, can cause superheating of enclosed pumpage and result in a violent explosion. All necessary measures must be taken by the end user to ensure this condition is avoided.

 **WARNING**

The pump may handle hazardous and/or toxic fluids. Care must be taken to identify the contents of the pump and eliminate the possibility of exposure, particularly if hazardous and/or toxic. Potential hazards include, but are not limited to, high temperature, flammable, acidic, caustic, explosive, and other risks.

 **WARNING**

Pumping equipment Instruction, Operation, and Maintenance manuals clearly identify accepted methods for disassembling pumping units. These methods must be adhered to. Specifically, applying heat to impellers and/or impeller retaining devices to aid in their removal is strictly forbidden. Trapped liquid can rapidly expand and result in a violent explosion and injury.

ITT Goulds Pumps will not accept responsibility for physical injury, damage, or delays caused by a failure to observe the instructions for installation, operation, and maintenance contained in this Pump Safety Manual or the current IOM available at www.gouldspumps.com/literature.

SAFETY

DEFINITIONS

Throughout this manual the words **WARNING**, **CAUTION**, **ELECTRICAL**, and **ATEX** are used to indicate where special operator attention is required.

Observe all Cautions and Warnings highlighted in this Pump Safety Manual and the IOM provided with your equipment.



WARNING

Indicates a hazardous situation which, if not avoided, could result in death or serious injury.

Example: Pump shall never be operated without coupling guard installed correctly.



CAUTION

Indicates a hazardous situation which, if not avoided, could result in minor or moderate injury.

Example: Throttling flow from the suction side may cause cavitation and pump damage.



ELECTRICAL HAZARD

Indicates the possibility of electrical risks if directions are not followed.

Example: Lock out driver power to prevent electric shock, accidental start-up, and physical injury.









When installed in potentially explosive atmospheres, the instructions that follow the Ex symbol must be followed. Personal injury and/or equipment damage may occur if these instructions are not followed. If there is any question regarding these requirements or if the equipment is to be modified, please contact an ITT Goulds Pumps representative before proceeding.













Example:  Improper impeller adjustment could cause contact between the rotating and stationary parts, resulting in a spark and heat generation.



GENERAL PRECAUTIONS

WARNING

A pump is a pressure vessel with rotating parts that can be hazardous. Hazardous fluids may be contained by the pump including high temperature, flammable, acidic, caustic, explosive, and other risks. Operators and maintenance personnel must realize this and follow safety measures. Personal injuries will result if procedures outlined in this manual are not followed. ITT Goulds Pumps will not accept responsibility for physical injury, damage or delays caused by a failure to observe the instructions in this manual and the IOM provided with your equipment.

General Precautions		
WARNING		NEVER APPLY HEAT TO REMOVE IMPELLER. It may explode due to trapped liquid.
WARNING		NEVER use heat to disassemble pump due to risk of explosion from tapped liquid.
WARNING		NEVER operate pump without coupling guard correctly installed.
WARNING		NEVER run pump below recommended minimum flow when dry, or without prime.
WARNING		ALWAYS lock out power to the driver before performing pump maintenance.
WARNING		NEVER operate pump without safety devices installed.
WARNING		NEVER operate pump with discharge valve closed.
WARNING		NEVER operate pump with suction valve closed.
WARNING		DO NOT change service application without approval of an authorized ITT Goulds Pumps representative.
WARNING		<p>Safety Apparel:</p> <ul style="list-style-type: none"> ♦ Insulated work gloves when handling hot bearings or using bearing heater ♦ Heavy work gloves when handling parts with sharp edges, especially impellers ♦ Safety glasses (with side shields) for eye protection ♦ Steel-toed shoes for foot protection when handling parts, heavy tools, etc. ♦ Other personal protective equipment to protect against hazardous/toxic fluids
WARNING		<p>Receiving:</p> <p>Assembled pumping units and their components are heavy. Failure to properly lift and support equipment can result in serious physical injury and/or equipment damage. Lift equipment only at specifically identified lifting points or as instructed in the current IOM. Current manuals are available at www.gouldspumps.com/literature_ioms.html or from your local ITT Goulds Pumps sales representative. Note: Lifting devices (eyebolts, slings, spreaders, etc.) must be rated, selected, and used for the entire load being lifted.</p>
WARNING		<p>Alignment:</p> <p>Shaft alignment procedures must be followed to prevent catastrophic failure of drive components or unintended contact of rotating parts. Follow coupling manufacturer's coupling installation and operation procedures.</p>

General Precautions		
WARNING		Before beginning any alignment procedure, make sure driver power is locked out. Failure to lock out driver power will result in serious physical injury.
CAUTION		Piping: Never draw piping into place by forcing at the flanged connections of the pump. This may impose dangerous strains on the unit and cause misalignment between pump and driver. Pipe strain will adversely effect the operation of the pump resulting in physical injury and damage to the equipment.
WARNING		Flanged Connections: Use only fasteners of the proper size and material.
WARNING		Replace all corroded fasteners.
WARNING		Ensure all fasteners are properly tightened and there are no missing fasteners.
WARNING		Startup and Operation: When installing in a potentially explosive environment, please ensure that the motor is properly certified.
WARNING		Operating pump in reverse rotation may result in contact of metal parts, heat generation, and breach of containment.
WARNING		Lock out driver power to prevent accidental start-up and physical injury.
WARNING		The impeller clearance setting procedure must be followed. Improperly setting the clearance or not following any of the proper procedures can result in sparks, unexpected heat generation and equipment damage.
WARNING		If using a cartridge mechanical seal, the centering clips must be installed and set screws loosened prior to setting impeller clearance. Failure to do so could result in sparks, heat generation, and mechanical seal damage.
WARNING		The coupling used in an ATEX classified environment must be properly certified and must be constructed from a non-sparking material.
WARNING		Never operate a pump without coupling guard properly installed. Personal injury will occur if pump is run without coupling guard.
WARNING		Make sure to properly lubricate the bearings. Failure to do so may result in excess heat generation, sparks, and / or premature failure.
CAUTION		The mechanical seal used in an ATEX classified environment must be properly certified. Prior to start up, ensure all points of potential leakage of process fluid to the work environment are closed.
CAUTION		Never operate the pump without liquid supplied to mechanical seal. Running a mechanical seal dry, even for a few seconds, can cause seal damage and must be avoided. Physical injury can occur if mechanical seal fails.
WARNING		Never attempt to replace packing until the driver is properly locked out and the coupling spacer is removed.
WARNING		Dynamic seals are not allowed in an ATEX classified environment.
WARNING		DO NOT operate pump below minimum rated flows or with suction and/or discharge valve closed. These conditions may create an explosive hazard due to vaporization of pumpage and can quickly lead to pump failure and physical injury.

General Precautions		
WARNING		Ensure pump is isolated from system and pressure is relieved before disassembling pump, removing plugs, opening vent or drain valves, or disconnecting piping.
WARNING		Shutdown, Disassembly, and Reassembly: Pump components can be heavy. Proper methods of lifting must be employed to avoid physical injury and/or equipment damage. Steel toed shoes must be worn at all times.
WARNING		The pump may handle hazardous and/or toxic fluids. Observe proper decontamination procedures. Proper personal protective equipment should be worn. Precautions must be taken to prevent physical injury. Pumpage must be handled and disposed of in conformance with applicable environmental regulations.
WARNING		Operator must be aware of pumpage and safety precautions to prevent physical injury.
WARNING		Lock out driver power to prevent accidental startup and physical injury.
CAUTION		Allow all system and pump components to cool before handling them to prevent physical injury.
CAUTION		If pump is a Model NM3171, NM3196, 3198, 3298, V3298, SP3298, 4150, 4550, or 3107, there may be a risk of static electric discharge from plastic parts that are not properly grounded. If pumped fluid is non-conductive, pump should be drained and flushed with a conductive fluid under conditions that will not allow for a spark to be released to the atmosphere.
WARNING		Never apply heat to remove an impeller. The use of heat may cause an explosion due to trapped fluid, resulting in severe physical injury and property damage.
CAUTION		Wear heavy work gloves when handling impellers as sharp edges may cause physical injury.
CAUTION		Wear insulated gloves when using a bearing heater. Bearings will get hot and can cause physical injury.

ATEX CONSIDERATIONS and INTENDED USE

Special care must be taken in potentially explosive environments to ensure that the equipment is properly maintained. This includes but is not limited to:

1. Monitoring the pump frame and liquid end temperature.
2. Maintaining proper bearing lubrication.
3. Ensuring that the pump is operated in the intended hydraulic range.

The ATEX conformance is only applicable when the pump unit is operated within its intended use. Operating, installing or maintaining the pump unit in any way that is not covered in the Instruction, Operation, and Maintenance manual (IOM) can cause serious personal injury or damage to the equipment. This includes any modification to the equipment or use of parts not provided by ITT Goulds Pumps. If there is any question regarding the intended use of the equipment, please contact an ITT Goulds representative before proceeding. Current IOMs are available at www.gouldspumps.com/literature_ioms.html or from your local ITT Goulds Pumps Sales representative.

All pumping unit (pump, seal, coupling, motor and pump accessories) certified for use in an ATEX classified environment, are identified by an ATEX tag secured to the pump or the baseplate on which it is mounted. A typical tag would look like this:



The CE and the Ex designate the ATEX compliance. The code directly below these symbols reads as follows:

- II = Group 2
- 2 = Category 2
- G/D = Gas and Dust present
- T4 = Temperature class, can be T1 to T6 (see Table 1)

Code	Max permissible surface temperature °F (°C)	Max permissible liquid temperature °F (°C)
T1	842 (450)	700 (372)
T2	572 (300)	530 (277)
T3	392 (200)	350 (177)
T4	275 (135)	235 (113)
T5	212 (100)	Option not available
T6	185 (85)	Option not available

The code classification marked on the equipment must be in accordance with the specified area where the equipment will be installed. If it is not, do not operate the equipment and contact your ITT Goulds Pumps sales representative before proceeding.

PARTS

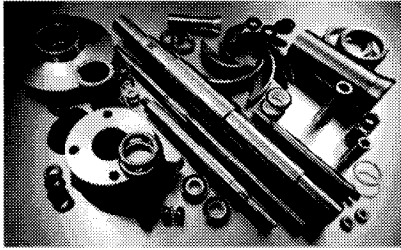

The use of genuine Goulds parts will provide the safest and most reliable operation of your pump. ITT Goulds Pumps ISO certification and quality control procedures ensure the parts are manufactured to the highest quality and safety levels.

Please contact your local Goulds representative for details on genuine Goulds parts.

TABLE OF CONTENTS

	PAGE
SECTION 1—INTRODUCTION	3
1-1 Introduction	3
1-2 Design	3
1-3 Information	3
1-4 Receiving and Checking	3
1-7 Materials and Equipment Required	3
SECTION 2—STORAGE	3
2-2 Storage	3
2-3 Storage Preparation	3
2-5 Recommended Storage Procedures	4
2-6 Preparations for Uncontrolled Long Term Storage	4
SECTION 3—GENERAL DESCRIPTION	4
3-2 Description	4
3-3 Drivers	4
3-5 Discharge	4
3-7 Bowl Assembly	4
SECTION 4—PUMP INSTALLATION	4
4-2 Preliminary Precautions	4
4-3 Preparing the Foundation	6
4-5 Preparing for Installation	6
4-7 Checking Resistance and Making Cable Splice	6
4-8 Energizing the Motor	7
4-10 Lowering Pump into Well	7
4-12 Current Check	8
4-14 Voltage Check	8
4-16 Electrical Cable	8
4-18 Electrical Control Equipment	8
4-19 Airline Installation and Operation	8
SECTION 5—GENERAL DISCUSSION	9
5-1 General	9
5-2 Operation at Shutoff Heads	10
SECTION 6—PUMP DISASSEMBLY AND REASSEMBLY	10
6-1 Pump Disassembly	10
6-5 Bowl Disassembly	11
6-7 Turbine Bowl—Wear Rings Removal	11
6-8 Turbine Bowl—Impeller Wear Ring Removal	11
6-9 Bowl, Suction Bell, and Discharge Bowl Bearing Removal	11
6-10 Inspection and Replacement	11
6-11 Turbine Bowl and Impeller Wear Ring Installation	11
6-12 Bowl, Suction Bell, and Discharge Bowl Bearing Installation	11
6-13 Turbine Bowl with Taper Collet—Reassembly	11
SECTION 7—PARTS LIST	19
7-1 General	19
7-2 Ordering Parts	19
7-3 Return Parts	19

SECTION 1—INTRODUCTION

1-1 INTRODUCTION

1-2 The design, material, and workmanship incorporated in the construction of Goulds' pumps makes them capable of giving long, trouble-free service. The life and satisfactory service of any mechanical unit, however, is enhanced and extended by correct application, proper installation, periodic inspection, and careful maintenance. This instruction manual was prepared to assist the operators in understanding the construction and correct methods of installing, operating, and maintaining these pumps.

1-3 Study thoroughly Sections 1 thru 6 and keep this manual handy for reference. Further information can be obtained by contacting the Vertical Pump Division, Goulds Pumps, Inc., City of Industry, California or your local branch office.

WARNING

GOULDS PUMPS, INC. WILL NOT BE LIABLE FOR ANY DAMAGES OR DELAY CAUSED BY FAILURE TO COMPLY WITH THE PROVISIONS OF THIS INSTRUCTION MANUAL.

1-4 RECEIVING AND CHECKING

1-5 The pump shall be carefully supported prior to unloading from the carrier. Handle all components carefully. Inspection for damage of the shipping crate shall be made prior to unpacking the pump. After unpacking, visually inspect the pump and check the following:

- A. Contents of the pump assembly against shipping list.
- B. All components against damage.

1-6 Any shortages or damages should be immediately called to the attention of the local freight agent of the carrier by which the shipment arrived and proper notation made on the bill. This shall prevent any controversy when claim is made and to facilitate prompt and satisfactory adjustment.

1-7 MATERIALS AND EQUIPMENT REQUIRED

1-8 The material and equipment necessary for installation of the pump will vary with the size of the pump and the type of installation. The following discussion and list of standard tools and supplies is therefore offered only as a guide.

A. BULK MATERIAL

Wooden friction blocks or steel clamps
Steel column lifting elevators of approved type and of proper size for the column pipe
Cable sling approximately 10 feet long of adequate size for the loads involved.

B. HAND TOOLS

Pipe Wrenches
Two chain tongs
Mechanic's hand tools

C. INSTRUMENTS

One megger, or similar instrument indicating electrical resistance.
Clamp-on ammeter
Voltmeter

A good grade of pipe joint compound should be available to facilitate assembly and possible future disassembly.

D. INSTALLATION EQUIPMENT

Although portable derricks are sometimes used, a properly designed pump setting rig is recommended. It must be possible to erect the crown block to a height so as to allow the load hook to be raised about three feet higher than the longest piece. The lifting device must be of sufficient strength and rigidity to raise the total weight of the unit safely.

CAUTION

REMEMBER—REGARDLESS OF THE TYPE OF LIFTING EQUIPMENT, OR THE TYPE OF PUMPING EQUIPMENT, THE PRIMARY RULE IS: SAFETY FIRST.

SECTION 2—STORAGE

2-1 STORAGE

2-2 Goulds Pumps carefully preserves and protects its products for shipment. However, the effective life of the preservatives applied at the factory can vary from 3 to 18 months depending on the severity of the environment in which the equipment is stored. This section provides procedures for preparation prior to storage and maintenance during storage of Goulds' pumps.

These procedures are necessary to protect the precision parts of the pumps. Specific procedures

for storing motors should be obtained from the motor manufacturer. This section is intended to be of general assistance to users of Goulds pumps. It shall not modify, amend, and/or otherwise alter the scope of Goulds Pumps warranty in anyway whatsoever.

2-3 STORAGE PREPARATION

2-4 Goulds' submersible pumps require proper preparation for storage. The pump shall be considered in storage when it has been delivered to

the job site and is awaiting installation. If a pump has been installed, but is not in regular operation, such as seasonal shutdown or an extended period of time, it is suggested that the pump be operated for at least 15 minutes every two weeks if possible.

2-5 RECOMMENDED STORAGE PROCEDURES

A. Controlled storage facilities should be maintained at an even temperature 10°F or more above the dew point with relative humidity less than 50% and little or no dust. (If these requirements cannot be met the pump is to be considered in uncontrolled storage.)

B. For uncontrolled storage periods of six months or less, the pump is to be inspected periodically to insure that all preservatives are intact.

C. All pipe threads and flanged pipe covers are to be sealed with tape.

D. The pump must not be stored closer than six inches to the ground.

2-6 PREPARATIONS FOR UNCONTROLLED LONG TERM STORAGE

2-7 Storage periods over six months require the preceding uncontrolled storage procedure plus the following:

A. Inspect the assembly and recoat periodically to prevent corrosion.

B. Place ten pounds of moisture absorbing dessicant or five pounds of vapor phase inhibitor crystals near the center of the pump. If the pump is assembled, place an additional one pound in the discharge nozzle securely fastened to the discharge flange.

C. Install a moisture indicator near the perimeter of the pump. Cover the pump with 6 mils minimum thickness black polyethylene or equal and seal it with tape. Provide a small ventilation hole approximately 1/2 inch diameter.

D. Provide a roof or a shed shelter to protect from direct exposure to the elements.

SECTION 3—GENERAL DESCRIPTION

3-1 GENERAL DESCRIPTION

3-2 Goulds' model VIS pump is a submersible turbine pump designed for maximum dependability. The VIS pump also features capacities from 100 to 6000 GPM and larger, heads to 1400 feet. See figure 3-1 for typical VIS pump.

3-3 DRIVERS

3-4 Goulds furnishes only internationally recognized motors designed for continuous operation under any thrust which may develop throughout the performance curve. Impeller adjustment and type of coupling, splined or clamped, is dependent

on the specific motor being used.

3-5 DISCHARGE

3-6 The discharge bowl provides an NPT connection which accepts the eduction pipe elbow or the first section of column pipe.

3-7 BOWL ASSEMBLY

3-8 The bowls are generally flanged construction for accurate alignment and ease of assembly and disassembly. Impellers are enclosed type, which eliminate field adjustment problems.

Pump Installation

All bolts are torqued by the factory and secured with Loctite. It is recognized that transportation and handling may result in bolt relaxation, therefore, check that all fasteners on the pump are tight prior to installation.

SECTION 4—PUMP INSTALLATION

4-1 PUMP INSTALLATION

4-2 Preliminary precautions should be taken prior to the final installation of the pump. The well and well site should be examined carefully in the following manner.

A. Check to insure sand has not covered the perforated sections of the well.

B. Determine that the well is of ample diameter and depth and is sufficiently straight to receive the pump. The submersible unit must be operated in a straight portion of the well. Exerted pressures can and will cause misalignment of bearings or cou-

plings. When the straightness of the well is not known, it is recommended to lower a test blank with the same diameter and length as the combined pump/motor assembly with electrical leads into the well to the desired depth. If there is any doubt about straightness, caging and plotting are recommended.

CAUTION

NEVER INSTALL UNIT WITH THE BOTTOM OF THE MOTOR CLOSER THAN FIVE FEET FROM THE BOTTOM OF THE WELL.

PART NO.	DESCRIPTION
649	COUPLING
660	PUMPSHAFT
661	BOWL DISCH.
670	BOWL INTMD.
671	ADAPTER SBM
672	BEARING INTMD.
673	IMPELLER
677	TAPER LOCK
680	WEAR RING-BOWL
690	BEARING-SUCTION/DISCH.
692	SAND COLLAR
698	SCREEN SUCTION

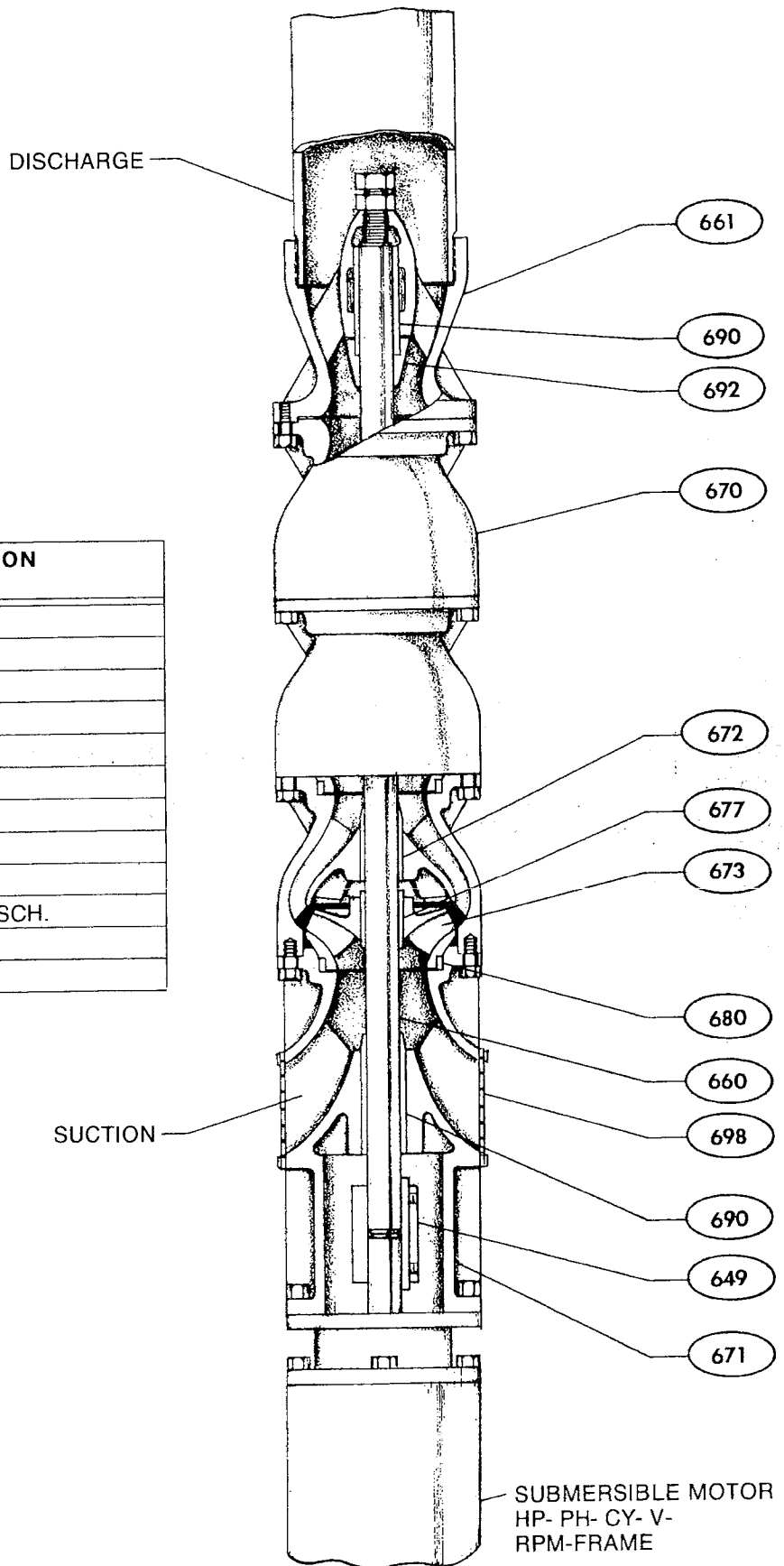

FIGURE 3-1

NOTE

In a previously used well, any obstruction such as jagged casing or other damage should be removed or corrected. Visual inspection may be performed through the use of an underwater television camera.

C. Any oil or oil emulsion must be removed from the surface of the water to prevent premature damage to the unit. It is possible to prevent fluid from entering the unit during installation by wrapping with an envelope of water soluble polyvinyl alcohol, but this will not protect the jacket material of the electrical conductor.

D. SURVEY THE WELL

Many wells have more than one size of casing installed and frequently the lower sections are smaller in diameter than the upper casing.

CAUTION

DO NOT INSTALL THE UNIT WITH THE MOTOR IN MUD, SAND, OR RESTING ON THE BOTTOM OF THE WELL. IT IS IMPORTANT TO PREVENT THE WELL FROM SANDING UP AT ANY TIME TO THE POINT THAT THE MOTOR BECOMES EVEN PARTIALLY BURIED.

4-3 PREPARING THE FOUNDATION

4-4 The foundation must be rigid, level, and of adequate strength to support the complete weight of the pump, motor, column, plus the weight of the liquid passing through it. It is recommended the foundation be constructed of solid concrete, however, adequate beams or timbers may be used. A common foundation consists of the following concrete mixture:

- A. One part cement
 - B. Two parts sand
 - C. Four parts gravel
- with sufficient water to make a stiff mix

4-5 PREPARATION FOR INSTALLATION

4-6 Lay out of the column pipe and bowl/motor assembly on suitable timbers keeping all material out of the dirt. Pipe coupling ends should be located towards the well. Clean all threads thoroughly and coat with joint compound as installed. All other parts should be laid out in the order in which they will be used.

4-7 CHECKING RESISTANCE

Before removing shipping skids, resistance of motor and cables should be checked with a proper instrument such as a megger. Make cable splice, if not already done at the factory, as follows:

TAPE CABLE SPLICE

A. Snip outer jacket in two or three places and remove jacket, with Sta-Kon or other similar pliers, peeling jacket back approximately one foot. Re-

move any cotton or other tape from individual conductors in order to expose the insulation of each wire. Strip the insulation of each conductor back far enough to allow the conductor to extend half way through a sleeve type connector. Crimp connector to the conductor. Strip motor lead insulation back far enough to fit into connector and butt against cable end. Crimp connector as before. Pull on wire to make sure connector is firmly crimped to both the motor lead and cable. Scrape the insulation to remove any loose bits of tape or thread and roughen surfaces. Thoroughly clean surfaces with a solvent (Naphtha, lacquer thinner, etc.). This will insure a watertight splice.

B. Using a self-bonding polyethylene based tape, start at the center of the connector and tape one inch past end of connector, stretching tape about 10% while taping. Overlap tape about one half of tape width. Continue taping back past connector one inch on the other side. This completes the first layer of tape. Upon completing each layer, coat tape with Scotch-Kote electrical coating 31K8B or a similar material. Tape next layer back past connector one inch farther than the first wrap so that the conductor is now taped two inches from the end of the connector. This completes the second layer. Tape back past the center again to opposite end, this time one inch farther than the second layer of tape, completing the third layer.

C. Tape back to the center and cut off the tape. Connector has now been taped at center with four layers of half lapped tape. Using vinyl plastic electrical tape, start at the center of the splice and tape one inch past the end of the insulating tape. Stretch the tape about 25% while taping and overlap about one-half tape width. Wrap to the other end, past the center of the splice and one inch past the end of the polyethylene based tape, thus completing the fifth layer. Tape sixth and seventh layers, extending each layer one inch past the previous one.

D. To finish the taped splice, tape back to the center and cut the tape off. The overall length of the taped splice should be approximately 12" long and have eight layers of tape, four insulating and four jacketing.

CAST CABLE SPLICE

A. To prepare the 3-conductor power cable for splicing, insert a sharp knife blade between the cable jacket and the lead insulation and strip the jacket back 2½" from the end, taking care not to cut the lead insulation. Strip the cambric wrapping (if any) off of the conductors and strip back rubber insulation ⅝" from the end. Assemble the cable connectors and crimp them in place using a crimping tool. If cables are too large for the connectors, cut off enough strands to reduce them to the size of the connectors.

B. Cut off the motor leads to equal length. Clean off the ends of the leads for about a foot, using a cloth wet with gasoline or solvent. Clean the end of the power cable also. Insert the three motor leads into the corresponding holes in the bottom

of the rubber casing and push them several inches out the top. Crimp the motor leads into the corresponding connectors, crimping the center one first. Bend the cables into line with the holes in the casing and slip the casing up until the connectors are inside the holes and about 1/4" from the top.

C. Mix the resin as directed, but squeeze the bag lightly when mixing, since it may rupture if too much pressure is applied. Cut off a corner of the bag and squeeze all of the resin into the casing. With the roll of tape at hand, fold the bag, and tape the top of the bag snugly to the power cable until the resin runs out over the top. This will assure maximum coverage of the resin and minimum size of the finished splice. It is not necessary to tape over the top of the casing, since the resin will seal it. When the resin is firm to the touch, the splice may be immersed for testing or for final installation.

D. Since the power cable is usually larger than the motor leads, it may be necessary to cut some of the strands of the larger cable and to fill out the smaller leads by bending some of the strands double. The use of the proper crimping tool is advised, but if one is not available, a sound connection can be made by flattening the connectors with a ball peen hammer and making one or two indents with a center punch. Avoid crushing the ends of the connectors since this may cause them to split open.

After splicing is completed, wet the splice and check resistance to ground. This can be achieved in the following manner:

A. Attach one pole of the megger to ground and the other pole of the megger to any one of the motor leads.

CAUTION

THE MINIMUM READING FOR EACH LEAD TO GROUND SHOULD BE 50 MEGOHMS.

B. To check phases for continuity, connect the megger poles to two of the three leads, altering until all three pairs of leads have been checked. Megger readings should all be zero, which indicates continuous circuit.

NOTE

Such a resistance check should be performed during and immediately after the completion of installation.

4-8 ENERGIZING THE MOTOR

4-9 Secure the pump and motor with chain tongs to resist torque. Energize the motor momentarily (on and immediately off) to check the rotation.

NOTE

Rotation will be counterclockwise when viewed from the discharge bowl.

If rotation is wrong, interchange any two of the motor leads at the control panel.

CAUTION

CORRECT ROTATION IS OF EXTREME IMPORTANCE. EXCESSIVE OVERLOADS MAY BE DEVELOPED UNDER OPERATING CONDITIONS WITH REVERSE ROTATION.

When the rotation is correct, mark the leads. At this time, copy the full load amperes from the motor name plate. This data will be required before starting the unit for the first time after it is in the well.

CAUTION

WITH THE LIFTING HOOK IN PLACE, SECURE THE CABLE ABOVE THE LIFTING HOOK TO AVOID TENSION ON THE MOTOR LEADS AND SPLICE.

4-10 LOWERING PUMP INTO WELL

4-11 Raise the bowl/motor assembly with the shipping skids still in place. Remove the shipping skids, and lower into well, clamping the bowl assembly near the top.

Attach the elevators to the bottom column pipe immediately below the column coupling. Hoist the column section into place above the well and the top of the bowl assembly, providing a soft board or pipe dolly for the end of the column pipe to slide in on so that threads will not be damaged while the section is being raised. Clean all threads and paint with thread lubricant. Thread the pipe into the discharge case connection and make up tight, using one set of chain tongs for back-up. The discharge pipe threads **MUST** be made up tight so that the motor torque will not loosen the joint during start-ups. A **MINIMUM** torquing force of ten foot pounds per rated motor horsepower **MUST** be applied to each threaded joint in order to resist the reaction of the torque applied by the motor during starts and stops.

Lower the unit into the operating location with the various pipe sections. Make up each joint tight as described above, keeping in mind the **MINIMUM** figure of 10 foot pounds per horsepower. Be very careful to keep the electrical cable from rubbing over sharp edges and position the elevators so as to avoid damage to the cable. Avoid twisting the unit, wrapping the cable around the pipe. Mount a cable guard directly above the couplings in convenient spacing. The cable guard spacing should not exceed 20 feet in any case. The first cable guard should be applied just above the splice and as near the bowl assembly as practical. Be sure that the cable remains reasonably taut and on the same side of the discharge pipe during complete installation. Place the final cable guard approximately 3 feet below the surface plate, leaving a small amount of slack in the cable. If other types of cable guards are used, refer to the assembly drawing for installation. Lower the discharge elbow into position on the discharge pipe and make up tight. Insert cable through surface plate or through channel if provided in foundation and on into the terminal box or to the motor control

panel.

The unit may now be lowered onto the foundation, with extreme care to avoid damage to the electrical cable. Lowering MUST be done gently and evenly with NO jerks or impacts. Insert flange bolts if used and tighten evenly. Any future disassembly may be accomplished by reversing the procedure.

4-12 CURRENT CHECK

4-13 With a suitable ammeter, read the current of the three phases immediately upon starting, then while pump is running at its rated capacity and head. The average of the three current readings in the three phases should be approximately equal to full load current on the nameplate, assuming a full torque load on the motor. If the average current exceeds the nameplate value by over 15% at any time, stop the unit immediately. Such high current is an indication that something is wrong, the cause of which must be determined before the motor is operated. Please note that this is a quick initial check. Actual power input must be established with a watt-hour meter.

4-14 VOLTAGE CHECK

4-15 In addition to showing proper average current, the individual values of line current should be approximately equal. If the current in any leg differs from the average value of all three by more than 5%, the supply voltage is probably unbalanced. A voltmeter reading should be taken on each of the three phases with the pump running. The average of the readings should be within plus or minus 10% of the motor nameplate rating at the motor, allowing for losses in the electrical conductor from point of reading to the motor. In addition, the maximum variation of any phase from the average value should not exceed one percent. The effect of unbalanced supply voltage is to create a current unbalance and increased losses in the motor far out of proportion to the magnitude of the voltage imbalance.

4-16 ELECTRICAL CABLE

4-17 It is also important that the cable be tested both before and during the installation. To test the cable after splice, connect one megger lead to the bowl assembly and the other lead to one of the cable leads at the cable reel. Minimum reading should be 50 megohms. Wet down the motor cable, splice, and as much of the cable as practical. The megger reading should be the same as before. If it reduces materially, there is a leak somewhere and it should be found by wetting down the cable a portion at a time, taking megger readings all the while. When testing the cable during installation, the cable should be megged every pipe section as soon as the motor reaches water level. To do this, connect one megger lead to the cable reel and the other lead to the discharge pipe. This will immediately indicate any cable damage during installation. Minimum reading should again be 50 megohms.

Since motor leads are marked for proper rotation, do not lose their identity. Check each single conductor of the cable with a megger before completing the installation of each cable connector. Common conductor ends are identified by low resistance reading of the megger. Mark each single conductor of the cable as the motor leads are marked, or record color of each conductor before making connection to motor leads.

Depending upon the clearance in the well casing, depth and straightness of the well, there may be some danger of pinching the cable between the column pipe coupling and well casing when lowering the unit. If Goulds Pumps protector-type cable supports are not used, a rubber padding may be used to cover the cable at these points if there is any danger of abrasion or pinching the cable. When lowering the unit, the discharge pipe should be held against the casing on the side opposite to the cable to allow as much clearance for the cable as possible.

Top of well casing may have sharp or rough edges and so it is important to protect the cable against cutting or scraping at this point also. A protective covering may be clamped over the rough well casing or the cable may be run over a pulley mounted high enough to allow the conductor to follow the discharge pipe down during the installation. Padding made of gasket material or something similar could also be used at the well head for protection.

4-18 ELECTRICAL CONTROL EQUIPMENT

Starting switches will usually be of the type used in connection with surface motors; however, attention is drawn to the difference between submersible motors and surface motors as regards full load current ratings. This must be taken into account when sizing protection devices. See overload allowables in foregoing pages.

It is recommended that quick-trip relays unaffected by ambient temperatures at the surface be installed to protect each of the three phases. For complete protection, fustrons may also be applied to each leg. Other controlling devices must depend on system design. This would include pressure switches and other such equipment. Additional protection should be provided to insure that the unit will not start or run unless adequate submergence is provided.

In areas where electrical storms are prevalent, the use of lightning arresters (in the case of three phase motors, two arresters) is excellent motor protection.

4-19 AIRLINE INSTALLATION AND OPERATION

An airline submerged in the well water provides the simplest method of determining the depth to the water level.

To use an airline, it is necessary to know the exact

length of the line from a reference point, generally the discharge elbow base. The airline should extend past the bowls to about the middle of the motor. As the length of discharge pipe is known, the distance to the top of the bowl assembly from the foundation is usually some multiple of 10 feet. Mark a point on the motor if the airline is to extend to that depth. Measure the distance of the point below the lowest section of discharge pipe and add it to the discharge pipe length. This is the total length of airline.

While the bowl assembly is in an upright position and before lowering into well, secure the first section of airline to it, placing the lower and open end on the mark. It is a good idea to slot the airline with a sawcut or two, some three to six inches above the bottom. This will reduce closure or clogging of the bottom end. Fasten the line in place so that it will not slip downward as additional sections are installed. It is recommended that the position of the upper end be marked on the discharge pipe as soon as each section of airline is installed so that it can be noted if any displacement occurs.

Add sections of airline at random length after the sections of discharge pipe have been installed and the pump is hanging from the hoist. It can be routed along with the power cable. Keep the airline outside of the elevators and fasten to the discharge pipe after removing the elevators at the foundation level. Each joint must be made up airtight to be effective; so use a thread sealing compound rather than a simple thread lubricant.

The last section of airline will have to be cut and fitted for length to match with the fittings furnished with the gauge and discharge elbow. Avoid hanging the weight of the airline on a fitting having its threads in a horizontal direction. For example, if the line is to hang from an elbow, support

the elbow rather than the horizontal nipple just behind the elbow.

Mount the gauge and air valve on the discharge elbow and connect the airline to it. It is generally good practice to remove the glass on the gauge and mark the depth of airline on the dial for record purposes. It will also be helpful to add the date of installation. If at any subsequent time an extension is added to the pump and the airline is extended also, the record on the gauge should then be brought up to date with the new length and new date.

Gauges are two types: direct reading and altitude. Each uses the same values of pressure to determine the depth. By pumping the airline full of air through the Schrader valve, the air pressure recorded at the surface of the ground is equal (within small limits) to the depth of water over the end of the airline.

With a direct reading gauge it is necessary to set the hand to a point on the dial equal to the length of airline. This must be done while there is no pressure on the gauge. Remove the Schrader valve core before making this adjustment. This gauge will read the distance to the water when the airline is pumped up. The hand will move away from the position equal to the pressure in the airline.

With an altitude gauge, this pressure is recorded directly on the gauge so that the depth of water is equal to the length of the airline, minus reading on the altitude gauge.

A periodic determination of water level recorded together with hours of pump operation form a vital record of the well performance and changes. Well performance will vary or may even deteriorate over a period of time and any required revisions in the pump can best be planned from a good well record.

SECTION 5—GENERAL

5-1 GENERAL

The use of column check valves is not recommended because of the danger of water hammer, sand locking, and of air accumulations under the valve that may airlock the pump and prevent the flow of water, any of which may damage the unit. Such valves are sometimes used, however, to control reverse flow back to pump, protecting the well in this manner. Prevention of reverse flow and consequent reverse rotation also protects the pump and motor from being started up while running backward. Under certain circumstances, it may be necessary to control backflow to eliminate overspeeding in reverse rotation, a condition which will not harm the pump but might damage the motor.

The motor maximum diameter and the minimum

inside diameter of the well shall be in such relationship that the minimum water velocity past the motor shall be one foot per second.

Developing the well, surging and freeing it from sand, are part of the well driller's contract and should be performed using a test pump. A new submersible pump should not be used to develop the well.

Never pull the discharge piping to the head with the cap screws or bolts. Install the pipeline so that the fasteners are used to prevent leakage only. Hanging the weight of the discharge line and fittings on the elbow is not recommended. Support the line by blocking or concrete saddles. Use a dresser-type coupling wherever possible, although adequate tie bars across the coupling must be provided in this case. Elbow must be securely anchored to foundation.

Never allow a pump to start while it is possible that it may still be rotating in the reverse direction after having shut down. It is advisable to install a time delay relay to prevent this. Replacing heaters with components of heavier rating than recommended if the pump load begins to trip those furnished originally is never advisable since these are protective devices. Contact your Goulds Pumps Representative for assistance.

It is considered good practice to avoid excessive cycling in any pumping operation. This is especially true with submersible pumps. If possible, the system should be arranged to require not more than two starts in each twenty four hours. Frequent cycling, such as once every couple of hours, could be injurious to the motor.

In all cases, it is recommended that regular maintenance schedules be established and followed. Making accurate recordings periodically of the various measurements recommended herein will permit preventive measures to be taken before trouble occurs. It will also provide information for the diagnosis of any difficulties.

5-2 OPERATION AT SHUTOFF HEADS

In the usual application of vertical turbine pumps, no harm will result from operation under conditions of static flowheads; however, not all installations are "usual" and, for this reason, considera-

Pump Operation

Pump shall not be operated outside of the preferred operating range except during startup. Do not operate pump below recommended minimum flow as severe damage may occur.

SECTION 6—PUMP DISASSEMBLY AND REASSEMBLY

6-1 PUMP DISASSEMBLY

NOTE

Pump components should be match-marked prior to disassembly.

6-2 Clear a large area adjacent to the pump as a storage space for pump parts as they are disassembled. If the pump has a long column arrange parallel timbers on the ground to support the pump column horizontally. After disassembly for repair or replacement of pump components, reassemble in all cases in the reverse order of disassembly.

6-3 It is recommended that maintenance personnel become thoroughly familiar with the VIS pump before performing any removal of the components. Consult the manufacturer's instructions for detailed disassembly information for the prime mover.

A. Remove the electrical connection at the conduit box and tag electrical leads at the motor.

WARNING

BEFORE OPENING THE CONDUIT BOX OF AN ELECTRICAL MOTOR, BE SURE THAT THE CURRENT TO THE MOTOR

tion should be given to any unit which may be subjected to this usage. The following points should therefore be checked and resolved before putting the equipment into operation at or near shutoff heads.

1. Thrust bearing capacity must be adequate.
2. If prolonged operation at no flow is contemplated, the problem of heat dissipation may become acute, since the entire shutoff horsepower is converted to heat in the available fluid.
3. For high pressure units, stresses at shutoff heads should be investigated. This information may be obtained from the factory upon request.
4. Certain impeller designs may have critical horsepower characteristics at low flows. Shutoff power requirements should be examined for driver overloads.
5. It must be kept in mind that impeller shaft bearings depend on pumped fluid for lubrication. Fluid temperatures, if raised excessively due to lack of flow, may impair lubrication efficiency and may also damage the motor through the excessive heat.

To summarize, designs will easily accommodate most of the considerations listed above. However, to obtain the best possible application, the factory should be notified at the time of order if operation at static flow heads will be a possibility and this precaution must be observed to validate any warranties.

IS SHUT OFF. SEVERE INJURY TO PERSONNEL COULD RESULT IF CONTACT WITH LIVE MOTOR LEADS IS MADE.

NOTE

Match-mark parts in sequence of disassembly to aid in the reassembly procedure.

B. Disconnect the discharge piping from discharge elbow.

WARNING

DO NOT WORK UNDER A HEAVY SUSPENDED OBJECT UNLESS THERE IS A POSITIVE SUPPORT UNDER IT WHICH WILL PROTECT PERSONNEL SHOULD A HOIST OR SLING FAIL.

6-4 In the following pump disassembly procedures references are made to installation sections of this manual, these sections will aid in the disassembly of the pump.

A. Disconnect discharge elbow and begin removal of column sections. Refer to Section 4-10.

B. For removal of bowl assembly and motor, hoist the bowl assembly from the well, using elevator clamps. Hoist in the same manner as for the col-

umn. Refer to Section 4. Proceed to disassemble the bowl assembly as follows.

6-5 BOWL DISASSEMBLY

6-6 The bowl assembly shown in Figure 3-1, is composed of a discharge bowl, intermediate bowl, enclosed impellers with taper collets, bearings, and pump shaft.

A. Begin disassembly by removing the capscrews that secure the discharge bowl and the first intermediate bowl, and slide off pump shaft.

B. Remove sand collar by heating. (Not the shaft.)

C. Pull shaft out as far as possible and strike impeller hub utilizing a collet driver or equivalent sliding along the pumpshaft to drive the impeller off the taper collet. (See Figure 6-1.A.)

D. After impeller is freed, insert a screwdriver into the taper collet to spread it. Slide taper collet and impeller off the pumpshaft.

E. Use the preceding procedures until entire turbine bowl assembly is completely disassembled.

6-7 TURBINE BOWL—WEAR RINGS REMOVAL

A. Utilizing a diamond point chisel, cut two "V" shape grooves on the bowl wear ring approximately 180 degrees apart. Use extreme care not to damage the wear ring seat.

B. With a chisel or equal, knock the end of one half of the ring in, and pry ring out.

C. On special materials such as chrome steel, set up the bowl in a lathe and machine the wear ring off, use extreme care not to machine or damage the ring seat.

6-8 TURBINE BOWL—IMPELLER WEAR RING REMOVAL

A. Set up impeller in a lathe and machine wear ring off, use extreme care not to machine or damage ring seat or impeller hub. Impeller wear ring may also be removed by following steps A and B paragraph 6-7.

6-9 BOWL, SUCTION BELL, AND DISCHARGE BOWL BEARING REMOVAL

A. Utilizing an arbor press and a piece of pipe or sleeve with outside diameter slightly smaller than bowl and retainer bearing housing, press the bearing off.

B. Remove suction bell bearing by setting suction bell on a lathe and machine bearing off. Suction

bell bearing and discharge bowl bearing may also be removed by using bearing pullers and pulling bearing out.

6-10 INSPECTION AND REPLACEMENT

A. Clean all pump parts thoroughly with a suitable cleaner.

B. Check bearing seats for deformation and wear.

C. Check shafts for straightness and excessive wear on bearing surfaces. Check deflection of shafts, average total runout shall not exceed 0.005 TIR for every 10 feet.

D. Visually check impellers and bowls for cracks and pitting. Check all bowl bearings for excessive wear and corrosion.

E. Replace all badly worn or damaged parts with new parts.

6-11 TURBINE BOWL AND IMPELLER WEAR RING INSTALLATION

A. Place chamfered face of bowl or impeller wear ring towards the ring seat and press into seat. Use an arbor press or equal. Make sure ring is flush with edge of wear ring seat.

6-12 BOWL, SUCTION BELL, AND DISCHARGE BOWL BEARING INSTALLATION

A. Press bearing into suction bell using an arbor press or equal. See Figure 3-1.

B. Press bearings into intermediate bowl and top bowl. Place the bowl with the flange downward and press bearing through chamfered side of bowl hub until bearing is flush with hub. Use an arbor press or equal.

6-13 TURBINE BOWL WITH TAPER COLLET—REASSEMBLY

A. For ease in reassembly of bowl assembly apply a thin film of turbine oil to all mating and threaded parts.

B. If a pumpshaft (660) is replaced, the sand collar is to be attached last to the shaft by a shrink fit. The shaft is machined with an 0.01 inch groove to locate sand collar, place large diameter of counterbore on sand collar towards discharge bowl bearing. Heat sand collar until it can slip on shaft.

C. To complete reassembly, reassemble in reverse order of Section 6-6, refer to Figures 6-2 thru 6-14.

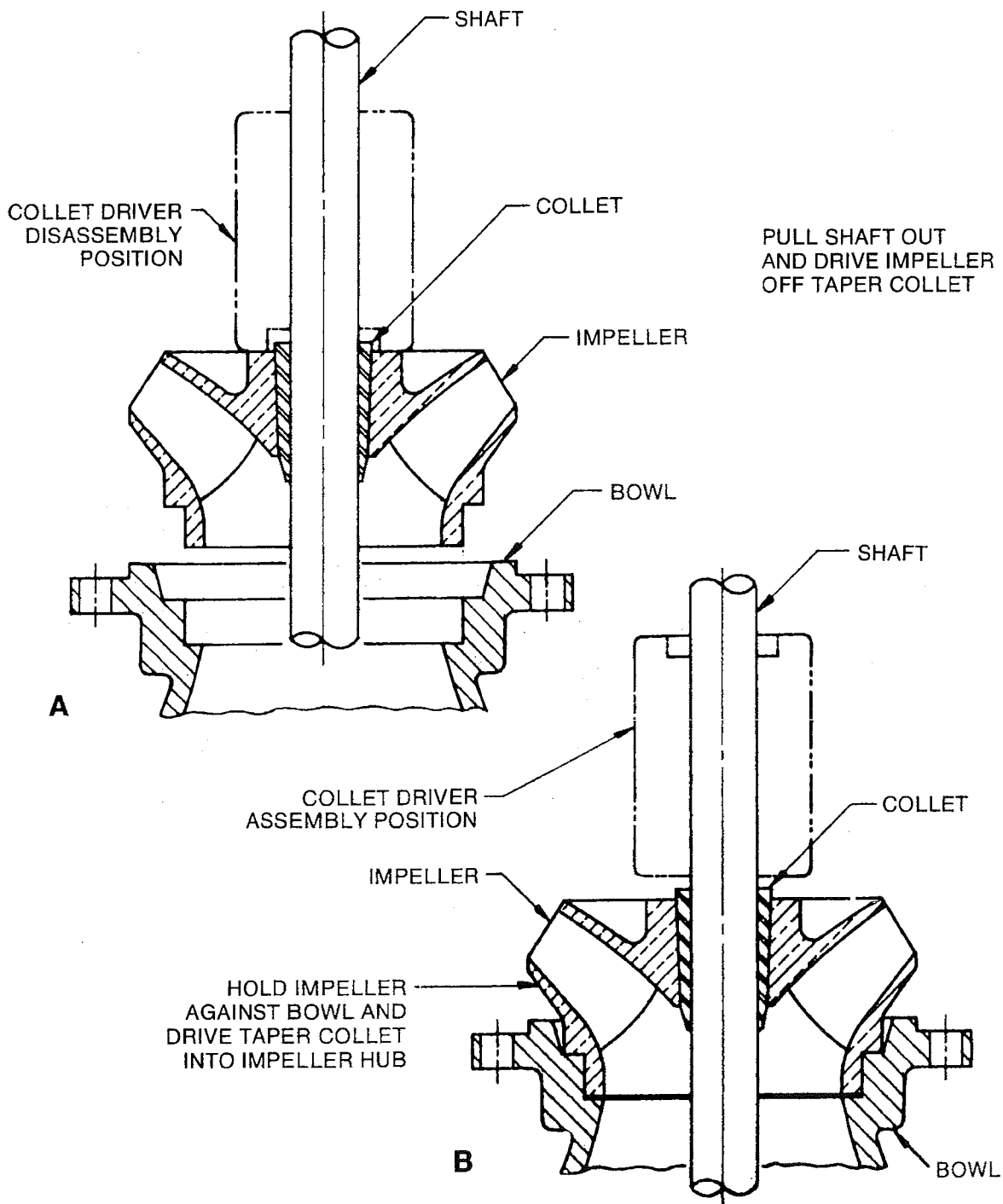

FIGURE—6-1 COLLET DRIVER

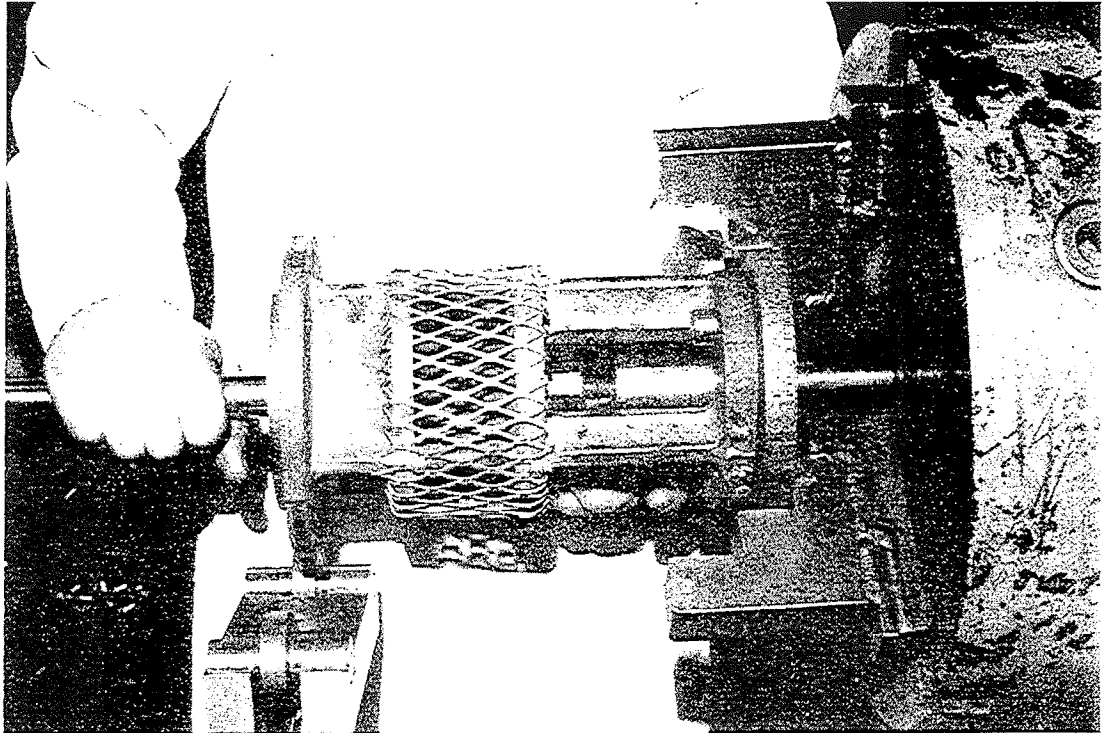

FIGURE 6-2

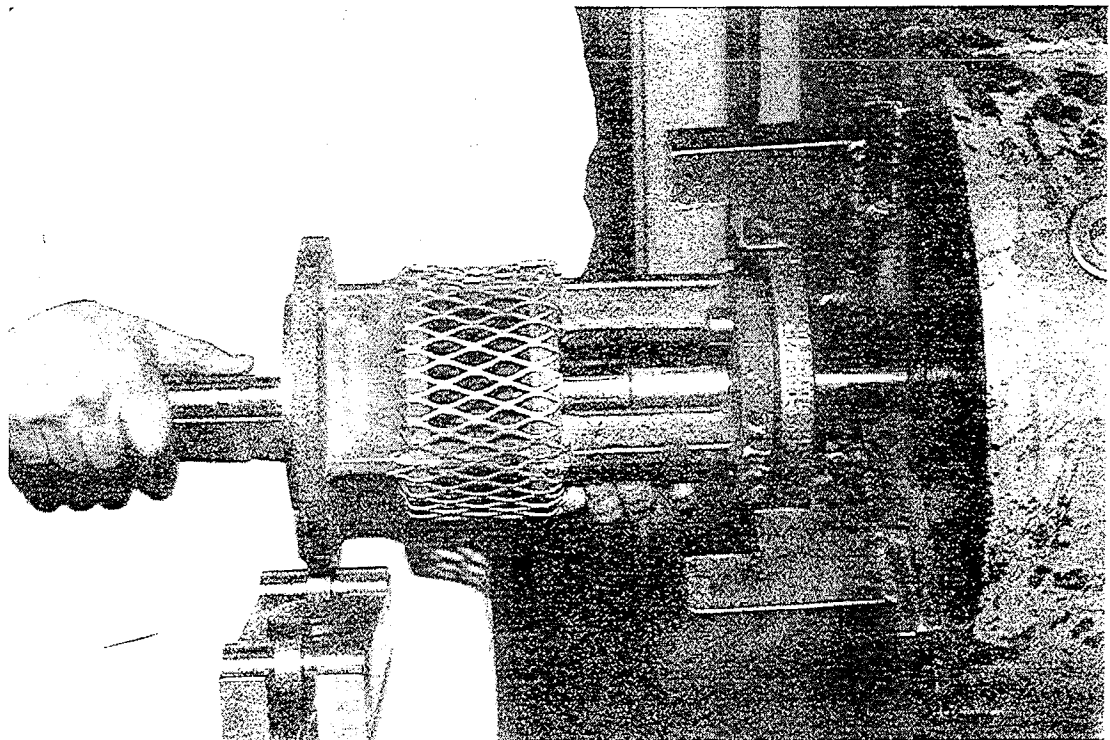

FIGURE 6-3

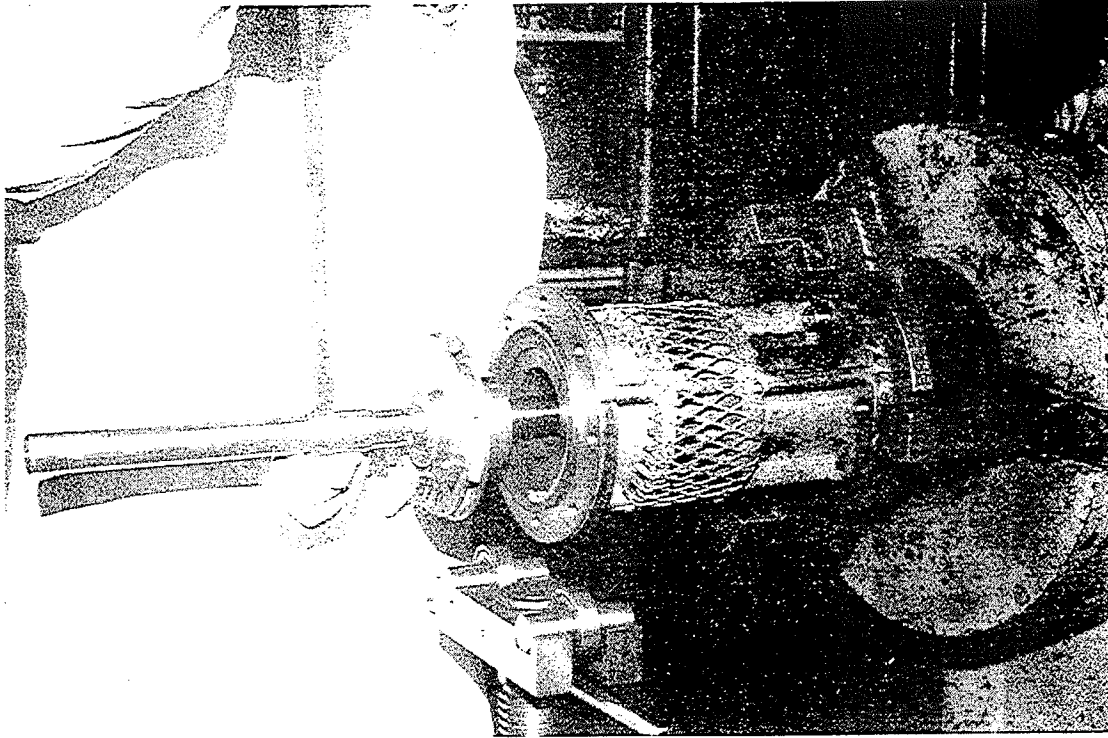

FIGURE 6-4

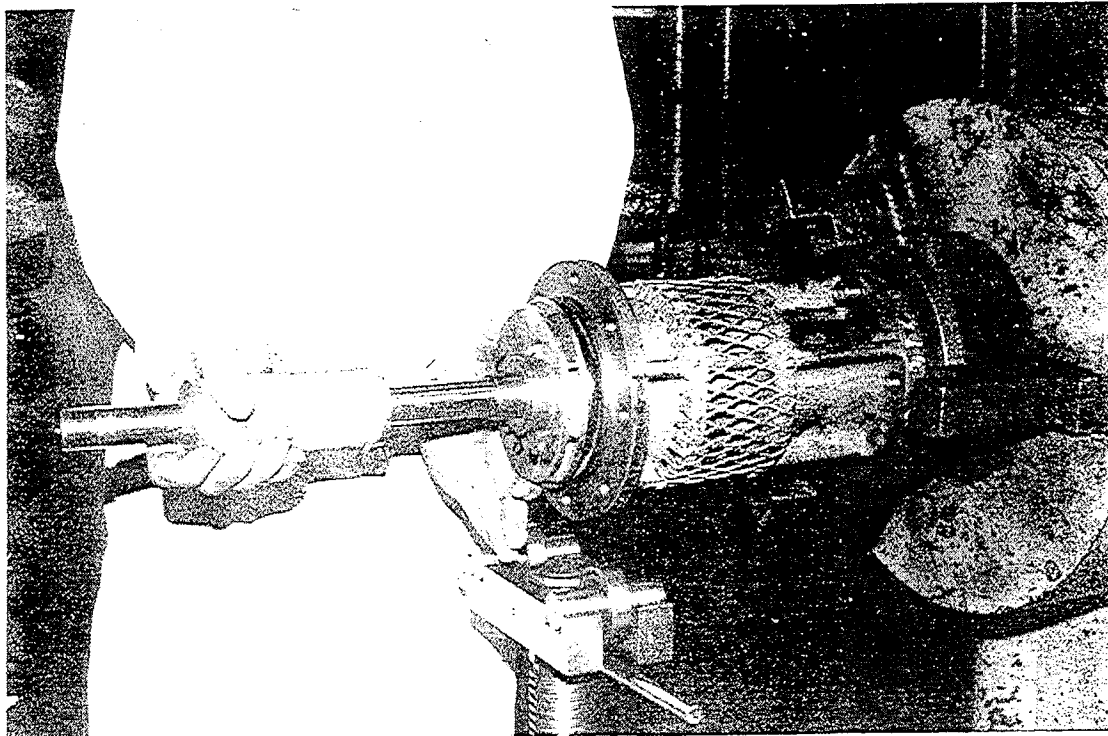

FIGURE 6-5

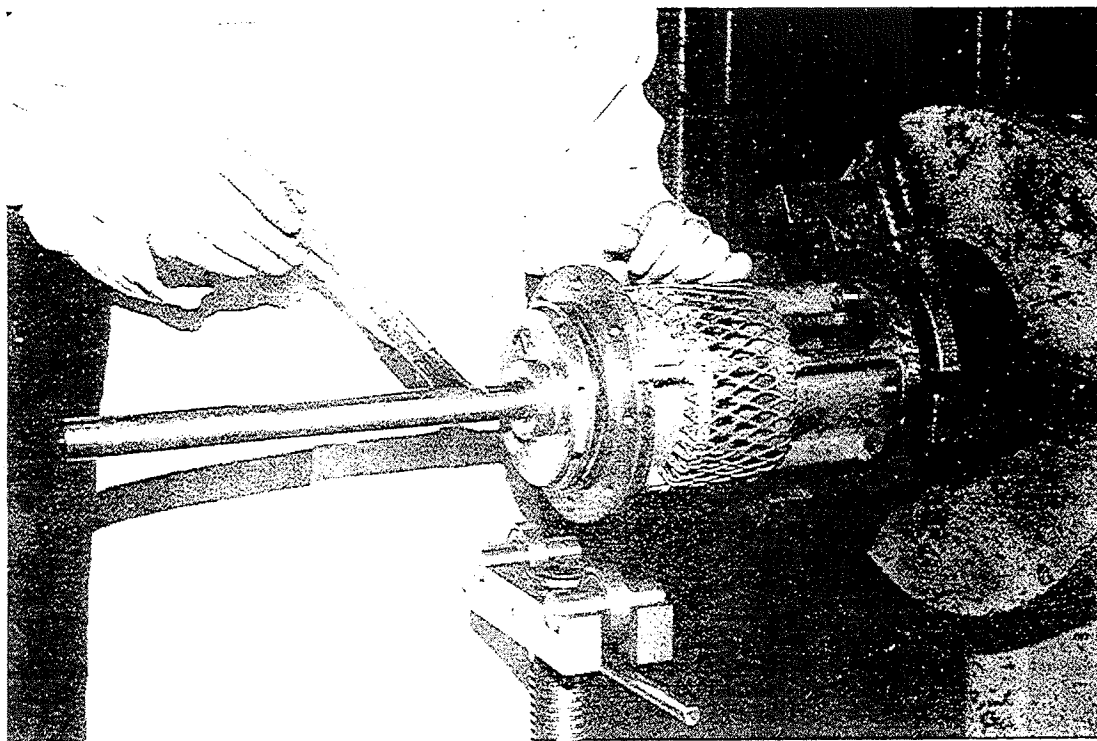

FIGURE 6-6

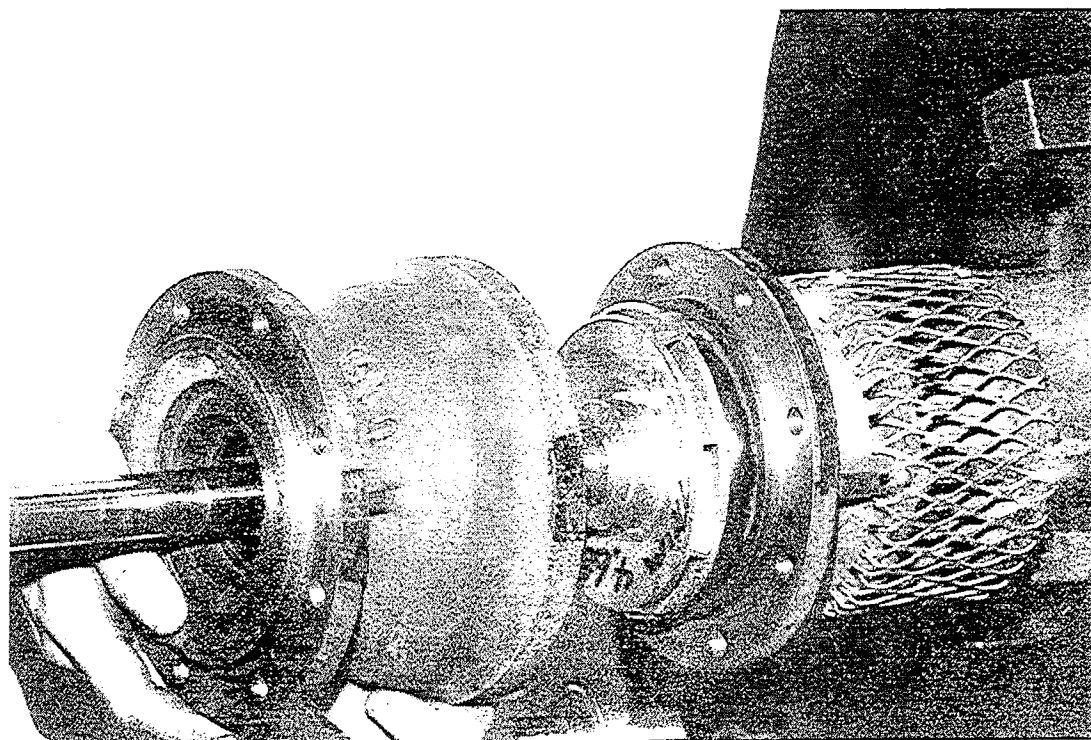

FIGURE 6-7

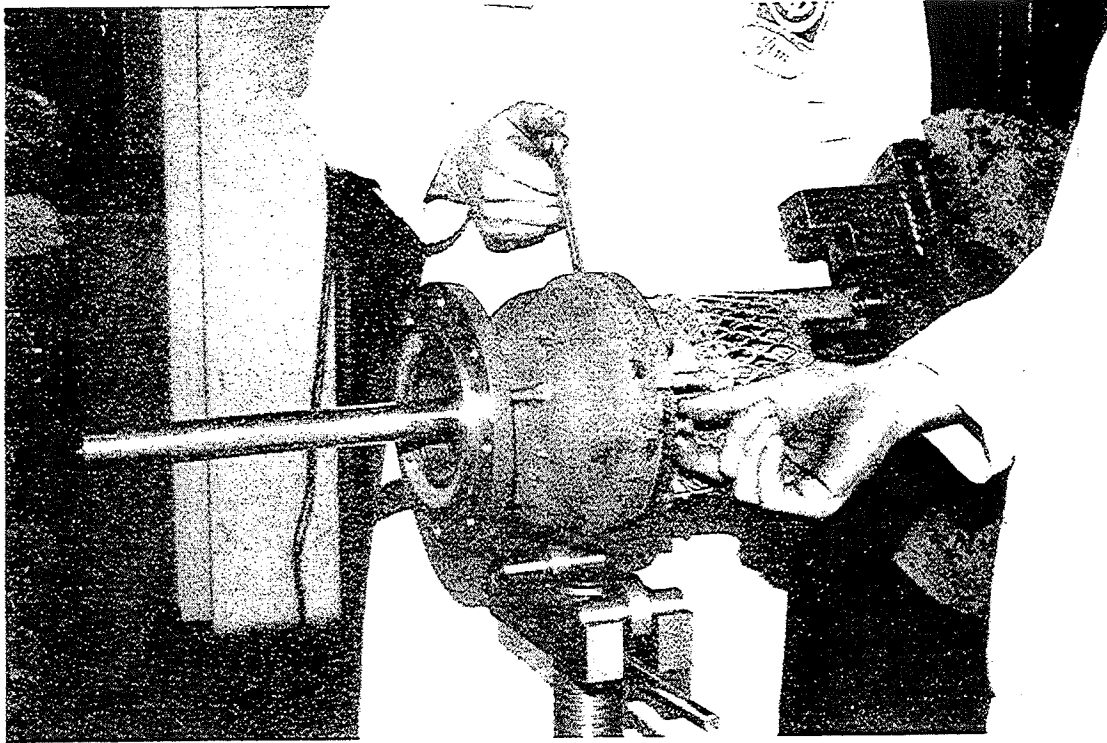

FIGURE 6-8

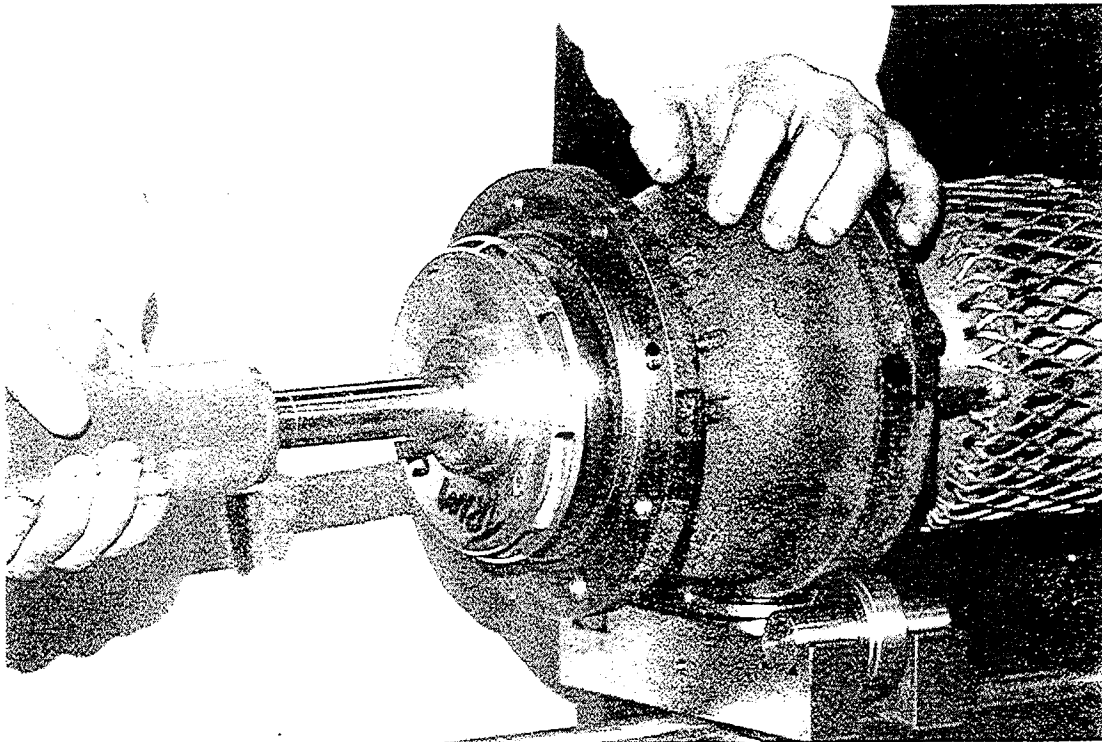

FIGURE 6-9

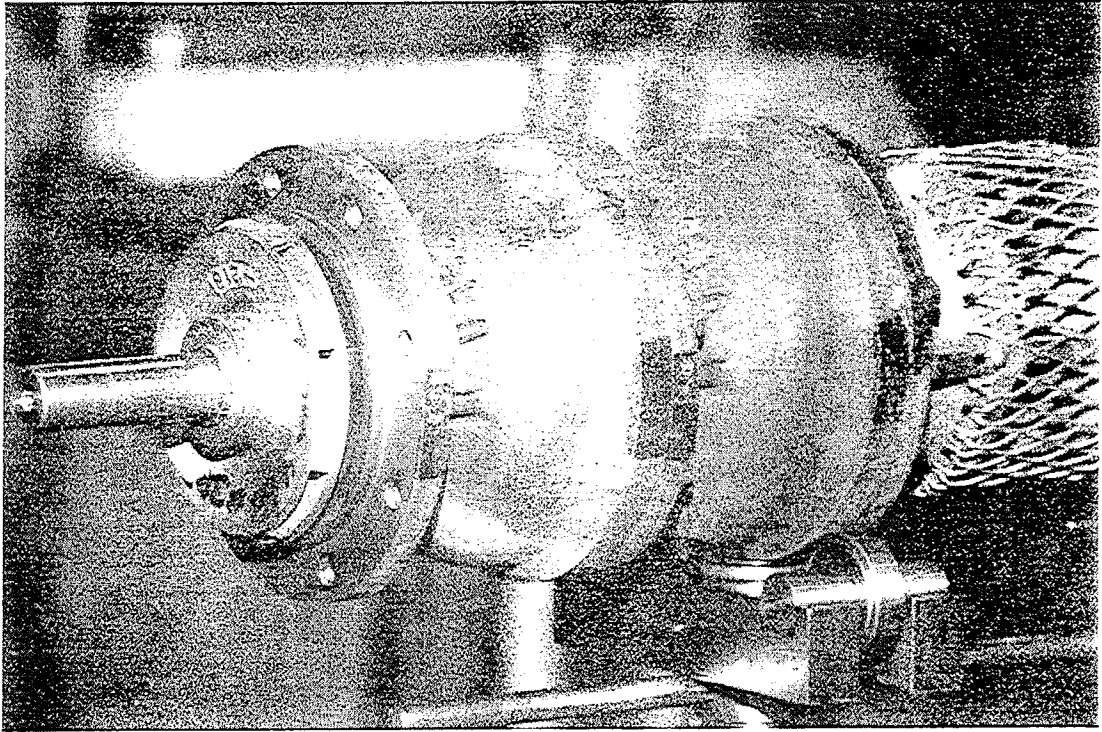

FIGURE 6-10

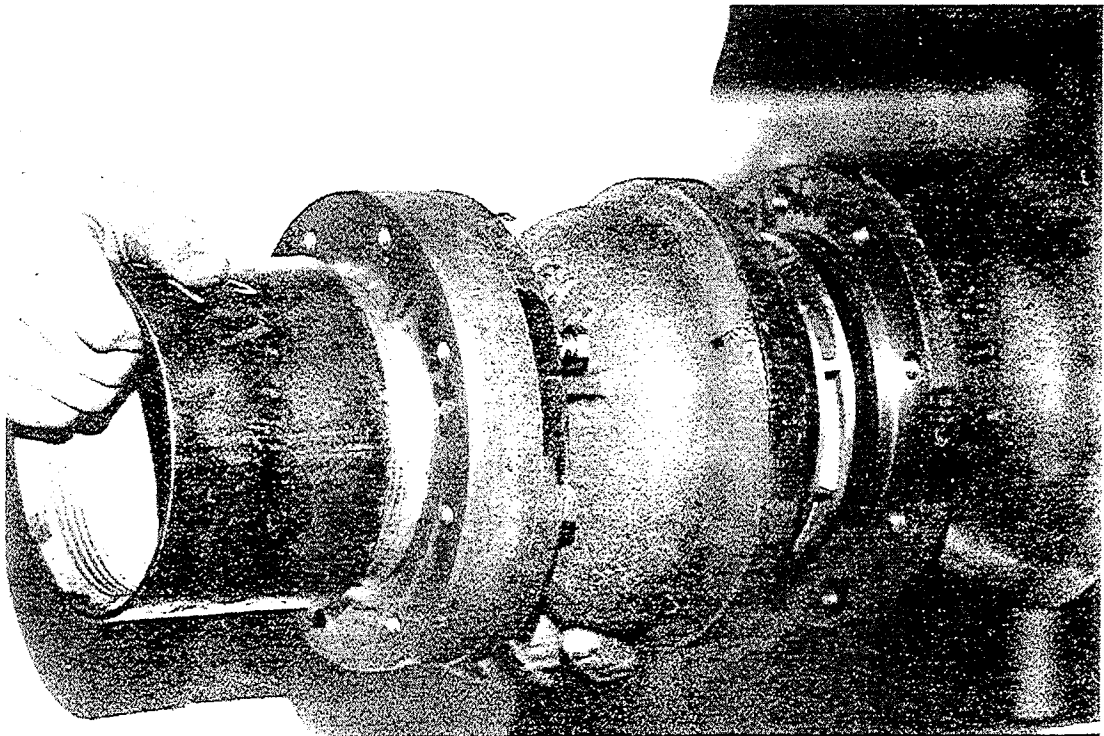

FIGURE 6-11

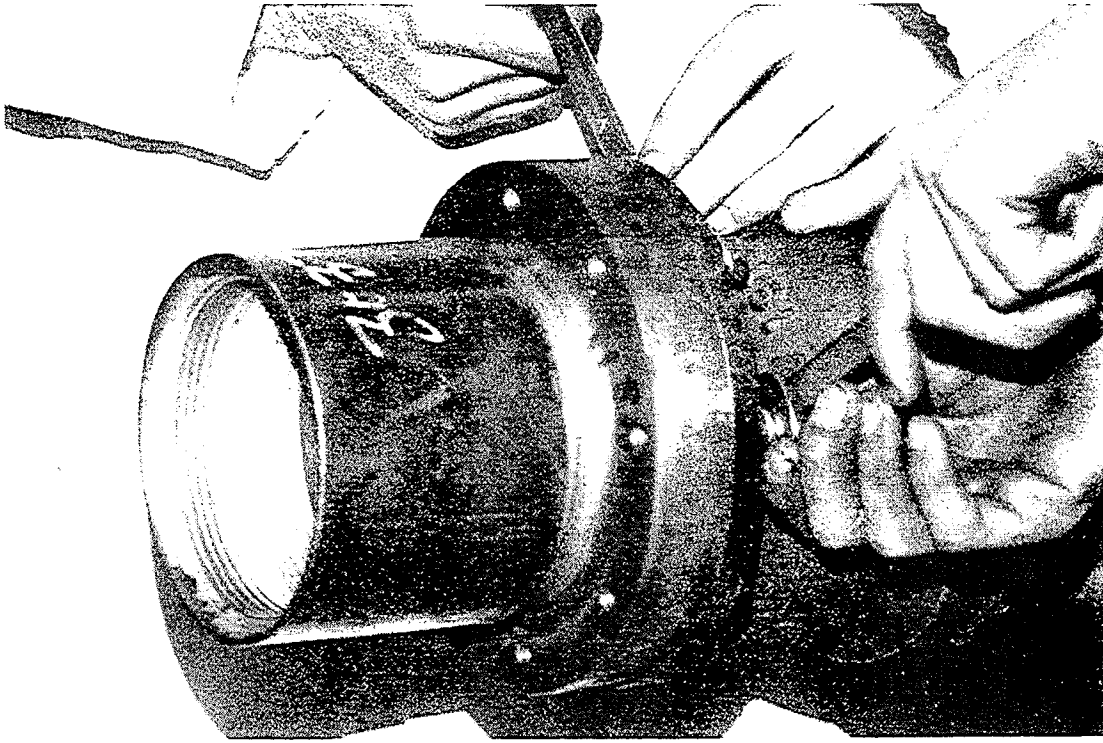

FIGURE 6-12

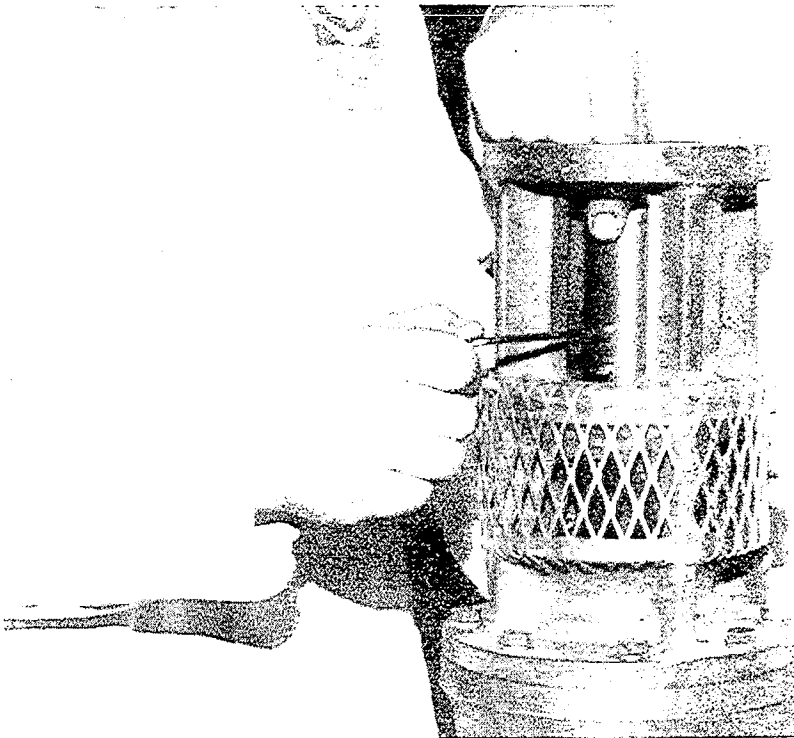

FIGURE 6-13

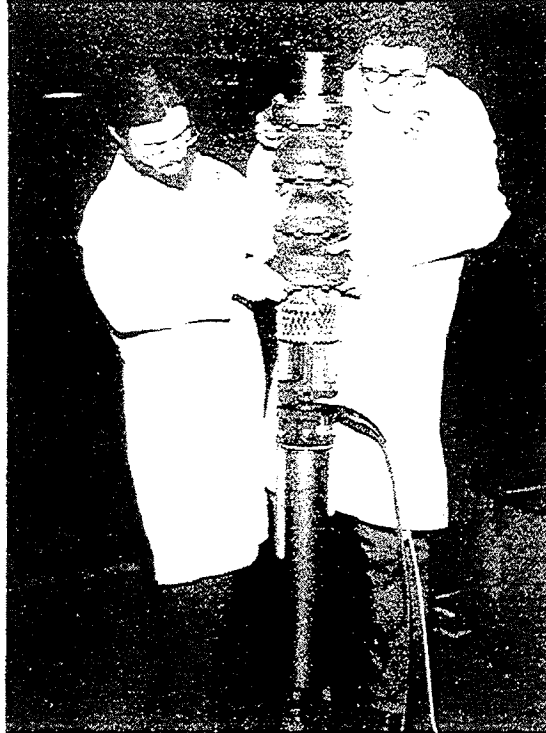

FIGURE 6-14

SECTION 7—PARTS LIST

7-1 GENERAL

The requirement for a stock of spare parts shall vary with the severity of conditions of service, and the extent of field maintenance anticipated, and the number of pumps installed. A minimum of one spare of each rotating part should be stocked, as well as a complete set of bearings and seals.

7-2 ORDERING PARTS

When ordering spare and replacement parts the pump serial number, type and size of pump must be given. Refer to nameplate. This is essential in order that Goulds Pumps may identify the pump and furnish the correct replacement part. Give the name and item number of the part as listed in parts list with the corresponding figure number and pump (See Figure 3-1). Orders for replacement parts should be sent to Sales Department, Goulds Pumps, Inc., Vertical Pump Division, City of Industry, California.

7-3 RETURN PARTS

All materials returned to factory must have a Return Material Order (RMO) tag attached. Consult

the nearest factory representative or Sales Office for shipping instructions and an RMO tag. Articles returned should be carefully packed to prevent damage in handling.

PART NO.	DESCRIPTION
649	Coupling
660	Pumpshaft
661	Bowl Disch.
670	Bowl Intmd.
671	Adapter SBM
672	Bearing Intmd.
673	Impeller
677	Taper Lock
680	Wear Ring-Bowl
690	Bearing-Suction/Disch.
692	Sand Collar
698	Screen Suction

Refer to Figure 3-1.

Pumps, and nothing but.

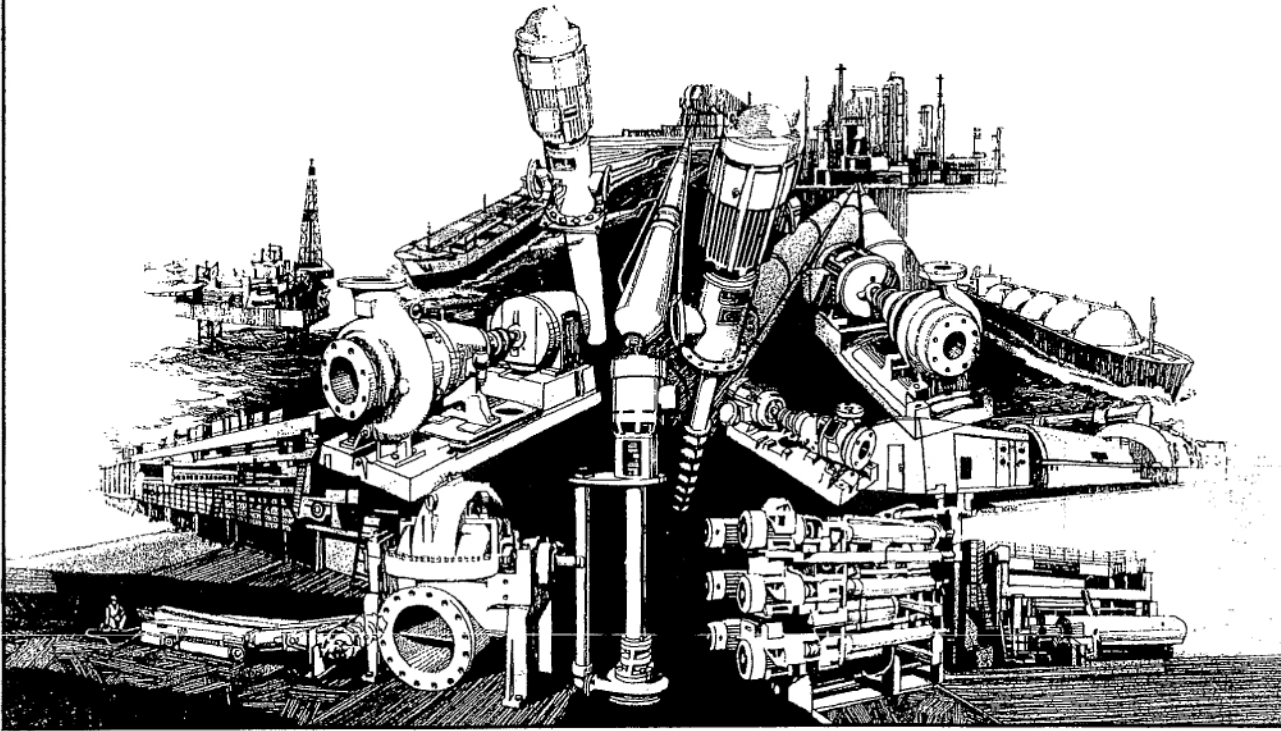

Goulds Pumps built its first pump in 1851 and has since grown to the largest manufacturer dealing exclusively with centrifugal pumps.

For more information, call your nearest Goulds sales representative or visit our website at www.gouldspumps.com



ITT