

Installation, Operation, and Maintenance Instructions



Models SRL, SRL-C
and SRL-XT

Goulds Pumps



ITT Industries
Engineered for life

NOTE

The information contained in this book is intended to assist operating personnel by providing information on the characteristics of the purchased equipment.

It does not relieve the user of their responsibility of using accepted engineering practices in the installation, operation, and maintenance of this equipment.

Any further questions, contact
ITT Industries - Goulds Pumps.
(519)824-7750

WARNING

Your pump was carefully selected, sized, manufactured and inspected with the utmost care to provide safe and reliable service, at the best possible efficiency to suit your specific pumping requirements. In the interest of trouble free pump operation and safety of operating personnel, the following safety precaution should be strictly adhered to.

- 1. READ AND FOLLOW CAREFULLY ALL RECOMMENDED PROCEDURES**, as described in your operator's manual, for storage, installation, start-up, operation and maintenance of your pump and related auxiliary equipment such as motor, variable speed drive, gear reducer, v-belt, coupling, etc.
- 2. DRIVER ROTATION MUST BE CHECKED** before first start-up and before the v-belts are installed or the coupling halves are connected. Severe equipment damage and injury to personnel may occur if the pump is driven in the opposite direction to the arrow of rotation cast on the pump casing.
- 3. DO NOT ALTER THE ORIGINAL OPERATING CONDITIONS** of the pump without first consulting with your local ITT Industries - Goulds Pump representative. The operation of the pump at conditions other than those for which it was designed may result in equipment damage and injury to operators.
- 4. DO NOT OPERATE THE PUMP AT LOW OR ZERO FLOW CONDITIONS.** All operating conditions which could cause the pumped liquid to vaporize are dangerous, such as clogged suction and discharge piping, shut-off suction and discharge valves, etc. Vapor pressure build-up could cause the pump casing and system piping to explode resulting in severe equipment damage and personal injury.
- 5. DO NOT USE HEAT TO ASSIST IN IMPELLER REMOVAL** from the shaft when servicing the pump. Heat can cause vaporization of fluid which may be trapped in the impeller hub resulting in an explosion which could cause personal injury and equipment damage.
- 6. DO NOT OPERATE THE PUMP WITHOUT PROPERLY INSTALLED V-BELT OR COUPLING GUARD.** Failure to install guards may result in personal injury.

Goulds Pumps



ITT Industries

IMPORTANT SAFETY NOTICE

To: Our Valued Customers

User safety is a major focus in the design of our products. Following the precautions outlined in this manual will minimize your risk of injury.

ITT Goulds pumps will provide safe, trouble-free service when properly installed, maintained, and operated.

Safe installation, operation, and maintenance of ITT Goulds Pumps equipment are an essential end user responsibility. This *Pump Safety Manual* identifies specific safety risks that must be considered at all times during product life. Understanding and adhering to these safety warnings is mandatory to ensure personnel, property, and/or the environment will not be harmed. Adherence to these warnings alone, however, is not sufficient — it is anticipated that the end user will also comply with industry and corporate safety standards. Identifying and eliminating unsafe installation, operating and maintenance practices is the responsibility of all individuals involved in the installation, operation, and maintenance of industrial equipment.

Please take the time to review and understand the safe installation, operation, and maintenance guidelines outlined in this Pump Safety Manual and the Instruction, Operation, and Maintenance (IOM) manual. Current manuals are available at www.gouldspumps.com/literature_ioms.html or by contacting your nearest Goulds Pumps sales representative.

These manuals must be read and understood before installation and start-up.

For additional information, contact your nearest Goulds Pumps sales representative or visit our Web site at www.gouldspumps.com.

SAFETY WARNINGS

Specific to pumping equipment, significant risks bear reinforcement above and beyond normal safety precautions.

 **WARNING**

A pump is a pressure vessel with rotating parts that can be hazardous. Any pressure vessel can explode, rupture, or discharge its contents if sufficiently over pressurized causing death, personal injury, property damage, and/or damage to the environment. All necessary measures must be taken to ensure over pressurization does not occur.

 **WARNING**

Operation of any pumping system with a blocked suction and discharge must be avoided in all cases. Operation, even for a brief period under these conditions, can cause superheating of enclosed pumpage and result in a violent explosion. All necessary measures must be taken by the end user to ensure this condition is avoided.

 **WARNING**

The pump may handle hazardous and/or toxic fluids. Care must be taken to identify the contents of the pump and eliminate the possibility of exposure, particularly if hazardous and/or toxic. Potential hazards include, but are not limited to, high temperature, flammable, acidic, caustic, explosive, and other risks.

 **WARNING**

Pumping equipment Instruction, Operation, and Maintenance manuals clearly identify accepted methods for disassembling pumping units. These methods must be adhered to. Specifically, applying heat to impellers and/or impeller retaining devices to aid in their removal is strictly forbidden. Trapped liquid can rapidly expand and result in a violent explosion and injury.

ITT Goulds Pumps will not accept responsibility for physical injury, damage, or delays caused by a failure to observe the instructions for installation, operation, and maintenance contained in this Pump Safety Manual or the current IOM available at www.gouldspumps.com/literature.

SAFETY

DEFINITIONS

Throughout this manual the words **WARNING**, **CAUTION**, **ELECTRICAL**, and **ATEX** are used to indicate where special operator attention is required.

Observe all Cautions and Warnings highlighted in this Pump Safety Manual and the IOM provided with your equipment.



WARNING

Indicates a hazardous situation which, if not avoided, could result in death or serious injury.

Example: Pump shall never be operated without coupling guard installed correctly.



CAUTION

Indicates a hazardous situation which, if not avoided, could result in minor or moderate injury.

Example: Throttling flow from the suction side may cause cavitation and pump damage.



ELECTRICAL HAZARD

Indicates the possibility of electrical risks if directions are not followed.

Example: Lock out driver power to prevent electric shock, accidental start-up, and physical injury.









When installed in potentially explosive atmospheres, the instructions that follow the Ex symbol must be followed. Personal injury and/or equipment damage may occur if these instructions are not followed. If there is any question regarding these requirements or if the equipment is to be modified, please contact an ITT Goulds Pumps representative before proceeding.













Example:  Improper impeller adjustment could cause contact between the rotating and stationary parts, resulting in a spark and heat generation.



GENERAL PRECAUTIONS

WARNING

A pump is a pressure vessel with rotating parts that can be hazardous. Hazardous fluids may be contained by the pump including high temperature, flammable, acidic, caustic, explosive, and other risks. Operators and maintenance personnel must realize this and follow safety measures. Personal injuries will result if procedures outlined in this manual are not followed. ITT Goulds Pumps will not accept responsibility for physical injury, damage or delays caused by a failure to observe the instructions in this manual and the IOM provided with your equipment.

General Precautions		
WARNING		NEVER APPLY HEAT TO REMOVE IMPELLER. It may explode due to trapped liquid.
WARNING		NEVER use heat to disassemble pump due to risk of explosion from tapped liquid.
WARNING		NEVER operate pump without coupling guard correctly installed.
WARNING		NEVER run pump below recommended minimum flow when dry, or without prime.
WARNING		ALWAYS lock out power to the driver before performing pump maintenance.
WARNING		NEVER operate pump without safety devices installed.
WARNING		NEVER operate pump with discharge valve closed.
WARNING		NEVER operate pump with suction valve closed.
WARNING		DO NOT change service application without approval of an authorized ITT Goulds Pumps representative.
WARNING		<p>Safety Apparel:</p> <ul style="list-style-type: none"> ♦ Insulated work gloves when handling hot bearings or using bearing heater ♦ Heavy work gloves when handling parts with sharp edges, especially impellers ♦ Safety glasses (with side shields) for eye protection ♦ Steel-toed shoes for foot protection when handling parts, heavy tools, etc. ♦ Other personal protective equipment to protect against hazardous/toxic fluids
WARNING		<p>Receiving:</p> <p>Assembled pumping units and their components are heavy. Failure to properly lift and support equipment can result in serious physical injury and/or equipment damage. Lift equipment only at specifically identified lifting points or as instructed in the current IOM. Current manuals are available at www.gouldspumps.com/literature_ioms.html or from your local ITT Goulds Pumps sales representative. Note: Lifting devices (eyebolts, slings, spreaders, etc.) must be rated, selected, and used for the entire load being lifted.</p>
WARNING		<p>Alignment:</p> <p>Shaft alignment procedures must be followed to prevent catastrophic failure of drive components or unintended contact of rotating parts. Follow coupling manufacturer's coupling installation and operation procedures.</p>

General Precautions		
WARNING		Before beginning any alignment procedure, make sure driver power is locked out. Failure to lock out driver power will result in serious physical injury.
CAUTION		Piping: Never draw piping into place by forcing at the flanged connections of the pump. This may impose dangerous strains on the unit and cause misalignment between pump and driver. Pipe strain will adversely effect the operation of the pump resulting in physical injury and damage to the equipment.
WARNING		Flanged Connections: Use only fasteners of the proper size and material.
WARNING		Replace all corroded fasteners.
WARNING		Ensure all fasteners are properly tightened and there are no missing fasteners.
WARNING		Startup and Operation: When installing in a potentially explosive environment, please ensure that the motor is properly certified.
WARNING		Operating pump in reverse rotation may result in contact of metal parts, heat generation, and breach of containment.
WARNING		Lock out driver power to prevent accidental start-up and physical injury.
WARNING		The impeller clearance setting procedure must be followed. Improperly setting the clearance or not following any of the proper procedures can result in sparks, unexpected heat generation and equipment damage.
WARNING		If using a cartridge mechanical seal, the centering clips must be installed and set screws loosened prior to setting impeller clearance. Failure to do so could result in sparks, heat generation, and mechanical seal damage.
WARNING		The coupling used in an ATEX classified environment must be properly certified and must be constructed from a non-sparking material.
WARNING		Never operate a pump without coupling guard properly installed. Personal injury will occur if pump is run without coupling guard.
WARNING		Make sure to properly lubricate the bearings. Failure to do so may result in excess heat generation, sparks, and / or premature failure.
CAUTION		The mechanical seal used in an ATEX classified environment must be properly certified. Prior to start up, ensure all points of potential leakage of process fluid to the work environment are closed.
CAUTION		Never operate the pump without liquid supplied to mechanical seal. Running a mechanical seal dry, even for a few seconds, can cause seal damage and must be avoided. Physical injury can occur if mechanical seal fails.
WARNING		Never attempt to replace packing until the driver is properly locked out and the coupling spacer is removed.
WARNING		Dynamic seals are not allowed in an ATEX classified environment.
WARNING		DO NOT operate pump below minimum rated flows or with suction and/or discharge valve closed. These conditions may create an explosive hazard due to vaporization of pumpage and can quickly lead to pump failure and physical injury.

General Precautions		
WARNING		Ensure pump is isolated from system and pressure is relieved before disassembling pump, removing plugs, opening vent or drain valves, or disconnecting piping.
WARNING		Shutdown, Disassembly, and Reassembly: Pump components can be heavy. Proper methods of lifting must be employed to avoid physical injury and/or equipment damage. Steel toed shoes must be worn at all times.
WARNING		The pump may handle hazardous and/or toxic fluids. Observe proper decontamination procedures. Proper personal protective equipment should be worn. Precautions must be taken to prevent physical injury. Pumpage must be handled and disposed of in conformance with applicable environmental regulations.
WARNING		Operator must be aware of pumpage and safety precautions to prevent physical injury.
WARNING		Lock out driver power to prevent accidental startup and physical injury.
CAUTION		Allow all system and pump components to cool before handling them to prevent physical injury.
CAUTION		If pump is a Model NM3171, NM3196, 3198, 3298, V3298, SP3298, 4150, 4550, or 3107, there may be a risk of static electric discharge from plastic parts that are not properly grounded. If pumped fluid is non-conductive, pump should be drained and flushed with a conductive fluid under conditions that will not allow for a spark to be released to the atmosphere.
WARNING		Never apply heat to remove an impeller. The use of heat may cause an explosion due to trapped fluid, resulting in severe physical injury and property damage.
CAUTION		Wear heavy work gloves when handling impellers as sharp edges may cause physical injury.
CAUTION		Wear insulated gloves when using a bearing heater. Bearings will get hot and can cause physical injury.

ATEX CONSIDERATIONS and INTENDED USE

Special care must be taken in potentially explosive environments to ensure that the equipment is properly maintained. This includes but is not limited to:

1. Monitoring the pump frame and liquid end temperature.
2. Maintaining proper bearing lubrication.
3. Ensuring that the pump is operated in the intended hydraulic range.

The ATEX conformance is only applicable when the pump unit is operated within its intended use. Operating, installing or maintaining the pump unit in any way that is not covered in the Instruction, Operation, and Maintenance manual (IOM) can cause serious personal injury or damage to the equipment. This includes any modification to the equipment or use of parts not provided by ITT Goulds Pumps. If there is any question regarding the intended use of the equipment, please contact an ITT Goulds representative before proceeding. Current IOMs are available at www.gouldspumps.com/literature_ioms.html or from your local ITT Goulds Pumps Sales representative.

All pumping unit (pump, seal, coupling, motor and pump accessories) certified for use in an ATEX classified environment, are identified by an ATEX tag secured to the pump or the baseplate on which it is mounted. A typical tag would look like this:



The CE and the Ex designate the ATEX compliance. The code directly below these symbols reads as follows:

- II = Group 2
- 2 = Category 2
- G/D = Gas and Dust present
- T4 = Temperature class, can be T1 to T6 (see Table 1)

Code	Max permissible surface temperature °F (°C)	Max permissible liquid temperature °F (°C)
T1	842 (450)	700 (372)
T2	572 (300)	530 (277)
T3	392 (200)	350 (177)
T4	275 (135)	235 (113)
T5	212 (100)	Option not available
T6	185 (85)	Option not available

The code classification marked on the equipment must be in accordance with the specified area where the equipment will be installed. If it is not, do not operate the equipment and contact your ITT Goulds Pumps sales representative before proceeding.

PARTS



The use of genuine Goulds parts will provide the safest and most reliable operation of your pump. ITT Goulds Pumps ISO certification and quality control procedures ensure the parts are manufactured to the highest quality and safety levels.

Please contact your local Goulds representative for details on genuine Goulds parts.

TABLE of CONTENTS

	Page
General Information	1 & 2
Start-up and Operation	3
Locating Trouble	4
Dismantling and Re-Assembly Procedure:	
Photos	5
2x2x10 SRL	6 & 7
3x3x10 SRL, 5x5x14 SRL, 6x6x15 SRL, 3x3x10 SRL-C and 5x4x14 SRL-C	8 & 9
8x6x18 SRL-C & 10x8x21 SRL-C	10 & 11
12x10x25 SRL-C	12 & 13
14x12x29 SRL-C	14 & 15
16x14x34 SRL-C	16 & 17
20x18x40 SRL-C	18 & 19
6x6x21 SRL-XT	20 & 21
8x8x25 SRL-XT	22 & 23
10x10x28 SRL-XT	24 & 25
14x12x36 SRL-XT	26 & 27
Rigid Liner	28

The law requires that the belt drives and/or couplings on this equipment be covered by **SAFETY GUARDS** while in operation. Such guards must be provided by the owner if not specifically contracted to ITT Industries - Goulds Pump.

GENERAL INFORMATION

INTRODUCTION

This manual is furnished to acquaint you with the easiest and most practical way to install, operate and maintain this pump. Keep it handy for future reference. Additional information can be obtained from the nearest ITT Industries - Goulds Pump sales office or certified dealer. The standards of the Hydraulic Institute are an excellent source for supplementary advice on the subject of installation, operation and maintenance of pumps. To keep the unit at top efficiency, correct procedures for installing and maintaining must be followed. The ITT Industries - Goulds Pump service organization can help install this equipment correctly so that maximum machine life can be obtained with a minimum of downtime.

PUMP IDENTIFICATION

The size and type designation of ITT Industries - Goulds Pump rubber-lined pumps includes the suction and discharge diameters and the nominal impeller diameter. For example, a 12x10x25 SRL-C pump has a 12" suction, a 10" discharge and a 25" diameter closed impeller.

INSPECTION

RECEIVING PUMP

Check pump for damage and material shortages after arrival. Prompt reporting to the carrier's agent, with notations made on the freight bill, will expedite satisfactory adjustment by the carrier.

2. Unload and handle the unit carefully.

NOTE: HOLES ON CASING LUGS ARE USED TO LIFT CASING HALVES ONLY. DO NOT USE FOR LIFTING ENTIRE UNIT.

TEMPORARY STORAGE

If the pump is not to be installed and operated soon after arrival, store it in a cool, dry and dark place, ideally 50°—70° F (10°- 21° C) with a maximum of 100° F (38° C). If stored below 32° F (0° C), some rubber products may become stiff and should be warmed before being placed in service. Do not store near electrical equipment which may generate ozone or in areas of known high ozone. Avoid direct or reflected sunlight. Certain insect and rodents thrive on rubber products so adequate protection should be provided. Rubber should not be stored in areas of high or low humidity. Oils, solvents, corrosive liquids and fumes could also adversely affect the rubber.

Rotate the shaft periodically to coat the bearings with lubricant and to retard oxidation and corrosion.

FOUNDATION

FOUNDATION

The foundation should be sufficiently substantial to absorb any vibration, and to form a permanent rigid support for the pump. A concrete foundation, with foundation bolts of the proper size grouted in place to drawing dimensions, is recommended.

MOUNTING OF PUMP

The foundation surface will support the pump with sole-plates under the frame at the foundation bolts. The sole-plates can be set in a puddle of grout and should be leveled in all directions, and in relation to each other. This will ensure a minimum amount of shimming necessary to completely level the pump.

Tighten the foundation bolts evenly and recheck for all round levelness of the pump.

PIPING

Note that piping should not be connected to pump until unit has been set per instructions and grouted in.

1. Support piping close to, but independently of pump.
2. Keep piping as straight as possible, with few or no bends and fittings.
3. Remove burrs, sharp edges, ream pipe cuts, and make joints air tight.
4. Do not "spring" pipes to make connection. Strain must not be transmitted to pump.

SUCTION PIPE

1. The suction pipe should be as short as possible, containing a minimum number of fittings. It should be so arranged that one section may be readily removed to allow the dismantling of the suction half casing. Victaulic or similar type couplings are recommended for this section of the pipe to facilitate dismantling. The suction pipe should slope upwards to the pump nozzle.
2. Suction line inlet in the sump must be flooded at all times, even if it necessary to install the pumps so that a suction lift is involved. The pump must never be throttled by the use of a valve on the suction side of the pump. It is advisable to have a shut-off valve in the suction line so that the pump can be isolated while repairs are being made, but this valve should never be used to control the capacity of the pump by throttling.

DISCHARGE PIPE

On long horizontal runs, it is desirable to maintain as even a grade as feasible. Avoid high spots, such as loops, which will collect air and throttle the system or lead to erratic pumping or surging.

GENERAL INFORMATION

LUBRICATION

All horizontal SRL, SRL-C, and SRL-XT pumps are designed for oil lubrication with anti-friction bearings. Before starting the pump flush the cylinder or frame liner with oil to remove any grit or dirt that may have entered the bearing housing during shipment or erection. Then refill with the proper lubricant to the operative level as shown by a line of the oil sight glass.

Experience shows that oils meeting the following specifications will provide satisfactory lubrication. These oils can be furnished by all major oil companies. It is the responsibility of the oil vendor to supply a suitable lubricant.

- 1) Saybolt viscosity at 100° F 300 SSU - 650 SSU
- 2) Saybolt viscosity at 210° F 50 SSU - 70 SSU
- 3) Viscosity index 90 - 100
- 4) API gravity 28 - 30
- 5) Pour point -5° F - 25° F
- 6) Flash point 430° F - 485° F
- 7) Additives rust and oxidation inhibitors

The oil should be well refined, premium to heavy duty type (API), filtered mineral oil with non-foaming characteristics. It must be free from water, sediment, resin, soaps, acid and fillers of any kind. It should also contain a protective agent against rust and wear. An SAE-20-30 grade with the above characteristics is recommended.

In installations with moderate temperature changes, humidity and dirt, the first oil change should be made after approximately 160 hours of operation. The oil should be inspected at this time to determine the operation period before the next oil change. Oil change periods may be increased up to 2000-4000 hours based on an 8000 hour year. Check the oil frequently for moisture, dirt or signs of "breakdown."

The bearings are also protected with a grease seal located in the bearing cover. A grease fitting is provided to fill cavity in the bearing cover with grease to prevent foreign matter from entering the bearing housing.

We recommend the use of a 30°-300° F (-1°-149° C) temperature range grease of about 1500 SSU at 100° F (38° C) (base oil viscosity). The grease should be of high quality, have shear stability, controlled adhesiveness and rust preventive additives.

CAUTION

DO NOT OVER OIL as this causes the bearings to run hot and fail prematurely. The **maximum** desirable operating temperature for ball bearings is 180° F (82° C). Should the temperature of the bearing frame exceed 180° F (82° C) (measured by thermometer), shut down pump to determine the cause.

Oils from different supplier should not be mixed.

STUFFING BOX

As standard construction, the pump will be supplied with stuffing box arrangement "A" for normal service. Where low dilution service is required, stuffing box arrangement "B" can be supplied upon request.

It is absolutely essential with any packed stuffing box to keep contaminants in the pump liquid from entering the packing space. These contaminants will cause severe abrasion or corrosion of the shaft sleeves, rapid packing deterioration, and can even plug the stuffing box flushing and lubrication system, causing the packing to run hot.

The stuffing box must be supplied at all times with a source of clean, clear water to flush and lubricate the packing. The sealing water should be supplied at about 10 psig above the discharge pressure of the pump, in quantities shown in Table 1.

Even when the pump is shut down, the sealing water should be left on unless the casing is relieved of the discharge pressure by isolating it from the static head in the discharge pipe.

The stuffing box should weep slightly, and only clear solution should appear at the gland. Care must be taken when packing and repacking the stuffing box to cut the packing into proper lengths (square ends just short of meeting). Install them with staggered joints, and place each ring in position before installing succeeding ring. Do not put too much tension on gland bolts. The standard packing is made from resilient non-asbestos fibers encapsulated by a protective TFE coating with break-in lubricant.

A soft well-lubricated packing reduces stuffing box resistance and prevents excessive wear on the shaft or shaft sleeve. Many brands of packing have the desired qualities. Those listed below should be regarded as typical rather than specific recommendations for replacement.

- | | | |
|----|----------------|-------------------------|
| 1. | Paperpack 5801 | Garlock Packing Company |
| 2. | #1335 | John Crane Canada Inc. |
| 3. | #5059 | Anchor Packing Company |

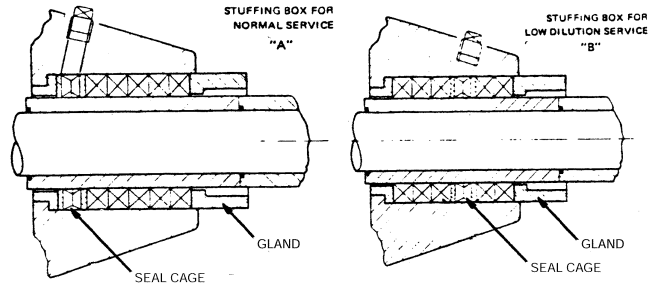

TABLE 1 Gland Water Requirements			
Pump Size		FLOW	NPT Conn.
SRL/SRL-C	SRL-XT	USGPM	Inches
2x2x10		1	3/8"
3x3x10		2	3/8"
5x4x14		4	3/8"
5x5x14		4	3/8"
6x6x15		6	3/8"
8x6x18		9	3/8"
10x8x21	6x6x21	12	3/8"
12x10x25	8x8x25	14	1/2"
14x12x29	10x10x28	16	1/2"
16x14x34	14x12x36	20	3/4"
20x18x40		25	3/4"

Notes:
 Values given above are for new pumps with new parts, handling clear water at 85° F (30° C). Values given are for "high dilution" arrangement ("A"). For "low" dilution arrangement ("B") reduce quantities by 50%.

The seal water should be supplied at about 10 PSI above the discharge pressure of the pump.

When designing the gland system, size it for 50% to 100% higher flows to allow for wear in the stuffing box bushing and increase flow due to fluctuations in the pressure differential between gland water systems and pump discharge pressure.

START-UP and OPERATION

STARTING THE PUMP

1. Check the direction of rotation of the driver. All SRL, SRL-C, SRL-XT, and SRL-XT pumps are designed for clockwise rotation (looking at the pump from the drive end). The impellers are held in place by right-hand threads. Incorrect rotation of the motor could cause the impeller to unscrew and jam against the casing liner, causing severe damage to the pump.
 2. Driver and driven sheaves must be carefully lined up parallel and square. On V-Belt applications, tension of the belts should be adjusted periodically. **It is very important belts be tensioned properly per belt manufacturer's recommendations. Under tensioned belts will cause belts to slip and over tensioned belts will put undue forces on shaft and bearings.** Mount coupling or belt guard before starting pump.
- NOTE: SAFETY GUARDS ARE MANDATORY FOR THIS EQUIPMENT. IT IS THE OWNER'S RESPONSIBILITY TO PROVIDE, AND/OR ALTER AND MAINTAIN THESE GUARDS IN ACCORDANCE WITH LOCAL SAFETY CODE REGULATIONS.**
3. Turn the shaft by hand to be sure that no solid material is impeding the impeller from rotating. This is particularly important if the pump has been idle with slurry in the casing. Solids could settle so that the shaft could not be turned by hand, and the casing would have to be opened to clear out the solids.
 4. Turn on the sealing water supply to the stuffing box, per instructions on page 2.
 5. Slowly admit slurry into pump, and prime the unit by flooding the entire casing.
 6. If a valve is installed in the discharge line, it should be closed as the initial load on the motor will be greatly reduced in this way.
 7. Start motor.
 8. Open discharge valve slowly.
 9. Check stuffing box to ensure there is a slight leakage of clear water. The gland bolts should not be much more than finger tight for proper operation.
 10. Check sump to be sure suction pipe is well flooded with slurry.

IMPELLER CLEARANCE

To obtain proper performance from the pump and increase parts wear life, it is recommended that the clearance between the impeller and suction side liner/wear plate be adjusted periodically. For instructions on the method of adjusting clearance, refer to individual instructions for dismantling and reassembly—pages 6 thru 27.

MAINTENANCE TIMETABLE

EVERY MONTH

Check bearing temperature with a thermometer, not by hand. If bearings are running hot, it may be the result of too much (or too little) lubricant. If changing the lubricant does not correct the condition, disassemble and inspect the bearings.

EVERY 3 MONTHS

Drain oil and flush oil reservoir and bearings. Refill to proper level with recommended grade of lubricant (see page 2).

EVERY 6 MONTHS

Check the packing and replace if necessary. Use the packing grade recommended.

Check shaft sleeve for scoring. Scoring accelerates packing wear, so do not install new packing on scored sleeves.

Check alignment of pump. Shim up units if necessary. If misalignment recurs frequently, inspect the entire piping system. Unbolt piping at suction and discharge flanges to see if it springs away, thereby indicating strain on the casing. Inspect all piping supports for soundness and effective support of load.

EVERY YEAR

Remove the rotating element. Inspect thoroughly for wear, and order replacement parts if necessary.

Remove any deposit or scaling. Clean out stuffing box piping.

LOCATING TABLES

HOW TO REMEDY PUMP TROUBLES

- FIND TROUBLE IN HEADING BELOW
- CHECK CAUSES
- FOLLOW SUGGESTED CURES

EXAMPLE NO LIQUID DELIVERED

1. Lack of prime. Fill pump and suction completely with slurry. Check for vapor bind.

NO LIQUID OR NOT ENOUGH LIQUID DELIVERED

1. *Lack of prime.*

Fill pump and suction completely with slurry. Check for vapor bind.

2. *Speed too low.*

Check whether motor is wired correctly and receiving full voltage across each phase. If frequency is too low, motor may have an open phase. Check V-Belt tension. Check sheave diameters.

3. *Discharge head too high.*

Check pipe friction losses. Larger piping may correct condition. Are valves wide open?

4. *Suction lift too high.*

Check for pipe friction losses as static lift may be too great. Measure with mercury column or vacuum gauge while pump operates. If static lift is too high, liquid to be pumped must be raised or pump lowered.

5. *Impeller completely or partially plugged.*

Dismantle pump and clean impeller.

6. *Obstruction at inlet.*

Check and remove.

7. *Defective packing*

Replace packing and sleeve if badly worn.

NOT ENOUGH PRESSURE

8. *Speed too low.*

See item 2.

9. *Obstruction in liquid passages.*

Dismantle pump and inspect passages of impeller and casing. Remove obstruction.

INCONSISTENT OPERATION

10. *Incomplete priming.*

Free pump, piping and valves of all air. If high points in suction line prevent this, they need correcting. See Suction Piping on page 2.

11. *Suction lift too high.*

See item 4.

12. *Stuffing box too tight.*

Release gland pressure. Tighten reasonably. If sealing water does not flow while pump operates, replace packing. Check shaft or shaft sleeve for scoring, replace if necessary. Always have slight leakage from packed stuffing box.

13. *Casing distorted by excessive strains from suction or discharge piping.*

Examine pump for rubbing between impeller and casing; replace damaged parts.

14. *Shaft bent due to thermal distortion, damage during overhauling, or improper assembly of rotating element.*

Check run-out by turning between lathe centers. Total run-out should not exceed .002" on all pumps.

15. *Mechanical failure of critical pump parts.*

Check bearings, and impeller for damage. Any irregularity in these parts will cause a drag on the shaft.

MOTOR OVERLOADS

16. *Liquid heavier (in specific gravity) than allowed for.*

Use larger driver. Consult pump manufacturer for recommended size. Test liquid for specific gravity.

17. *Speed may be too high (Brake HP of pump varies as the cube of the speed); therefore, any increase in speed means considerable increase in power demand.*

Check voltage on motor.

PHOTOS

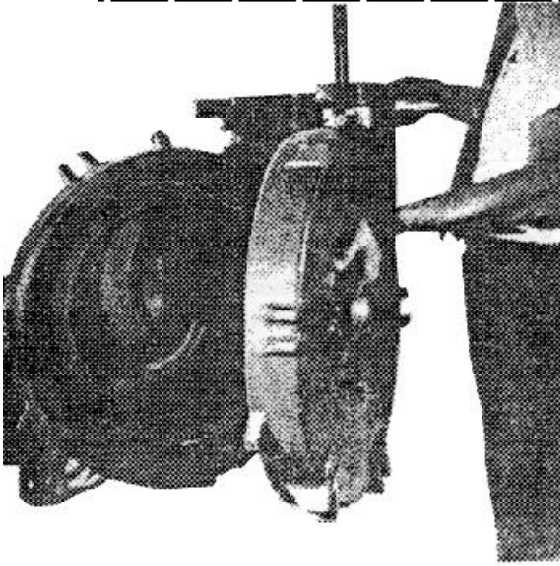

REMOVE CASING BOLTS AND SWING SUCTION HALF CASING OUT FROM PUMP

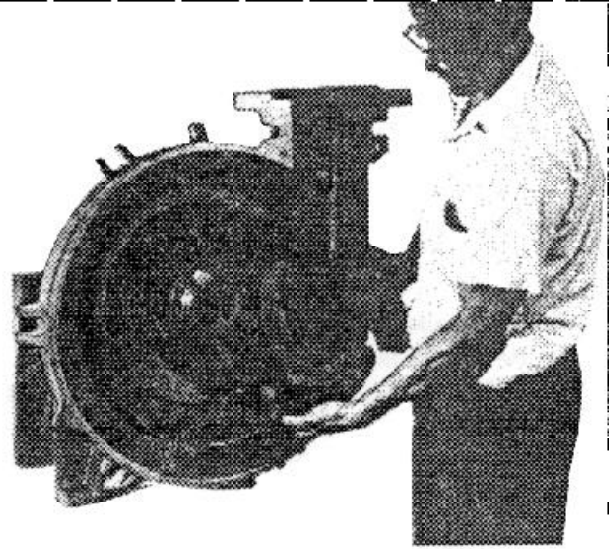

ALL IMPELLERS ARE SCREW ON DESIGN. GLAND SIDE RUBBER LINER MAY BE REMOVED, IF DESIRED.

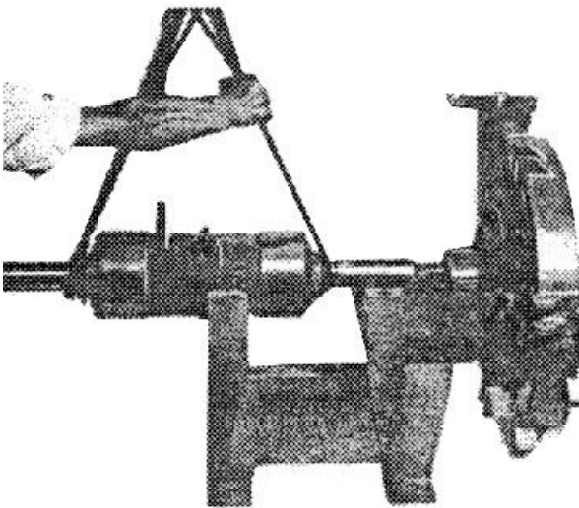

BEARING CYLINDER SHOULD BE ROTATED 180° TO ALLOW CLEARANCE. KEEP CYLINDER IN A HORIZONTAL POSITION DURING REMOVAL.

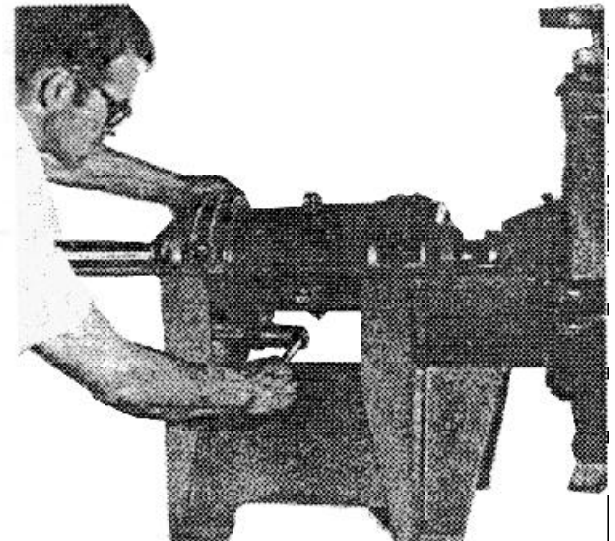

IMPELLER CLEARANCE ADJUSTMENT. JACKSCREW ACCESSIBLE FOR QUICK ADJUSTMENT. SECTIONAL ASSEMBLY AND PARTS LIST

SECTIONAL ASSEMBLY and PARTS LIST 2x2x10 SRL

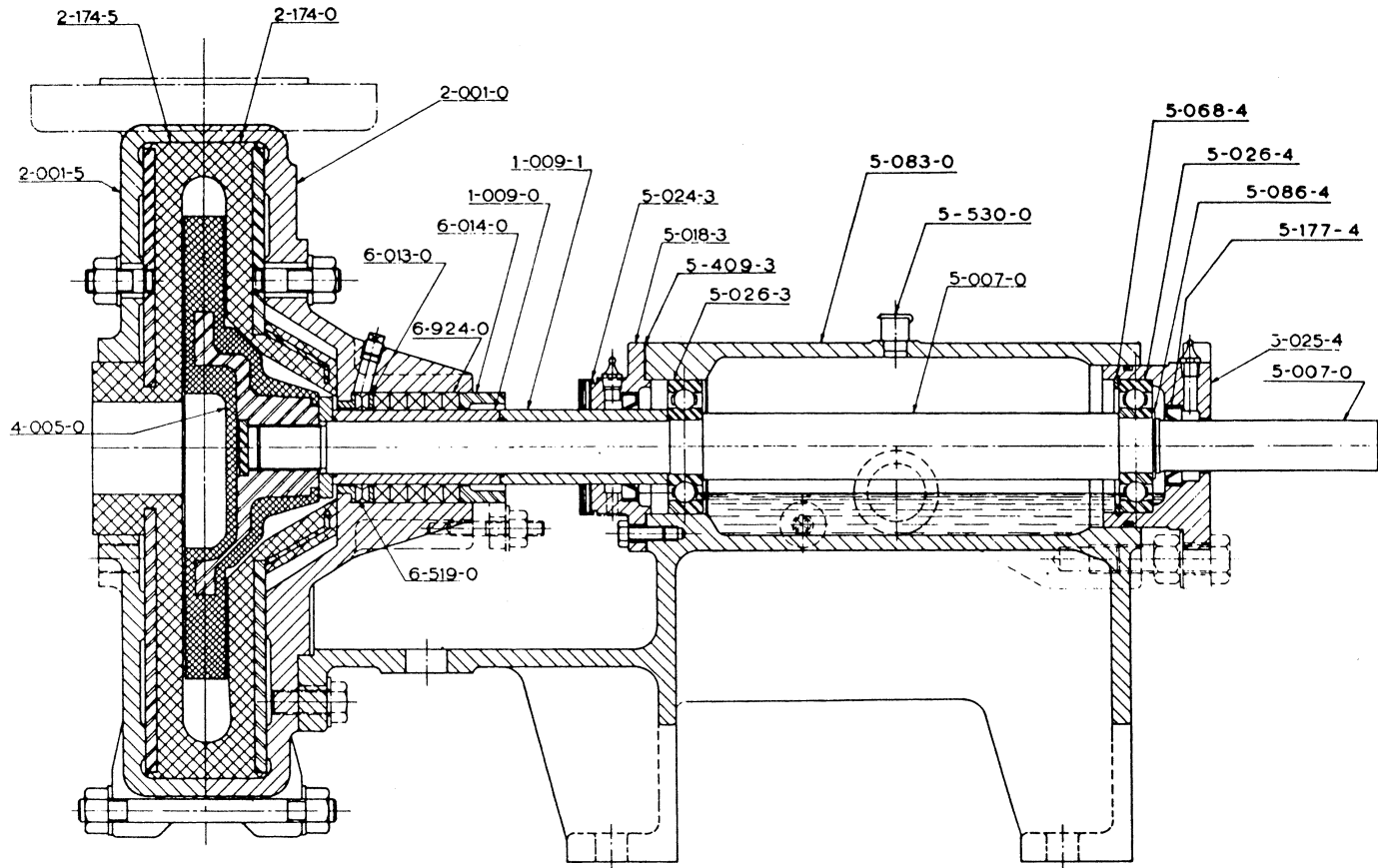

Cat No.	Description	Cat No.	Description	Cat No.	Description
1-009-0	Shaft Sleeve (St. Box)	5-018-3	Bearing Cover	5-177-3	Bearing Seal (Inb.)
1-009-1	Shaft Sleeve (Spacer)	5-024-3	Deflector	5-177-4	Bearing Seal (Outb.)
2-001-0	Gland Half Casing	5-025-0	Bearing Housing	5-409-3	Bearing Cover Gasket
2-001-5	Suction Half Casing	5-026-3	Ball Bearing (Inb.)	5-530-0	Oil Filler Cap With Vent
2-174-0	Gland Side Liner	5-026-4	Ball Bearing (Outb.)	6-013-0	Half Seal Cage
2-174-5	Suction Side Liner	5-068-4	Brg. Ret. Ring (Housing)	6-014-0	Gland
4-005-0	Impeller	5-063-0	Pedestal	6-519-0	Waterseal Bushing
5-007-0	Shaft	5-086-4	Brg. Ret. Ring (Shaft)	6-924-0	Packing

2x2x10 SRL

DISMANTLING PROCEDURE

1. Open casing by removing a section of the suction pipe, breaking discharge pipe connection, supporting discharge pipe and loosening and removing the bolts holding the casing halves together while making sure suction side casing is properly supported from dropping. Suction half casing (2-001-5) can then be removed. The suction side liner (rubber-lined, 2-174-5) may be removed by using jackscrew provided for that purpose.
2. Impeller (4-005-0) is mounted with a right hand thread. Rotation is clockwise when viewed from the pump drive end. To remove the impeller, hold the shaft to keep it from rotating and pound on a hardwood block held against the impeller vane at the periphery in the counterclockwise direction when viewed from the impeller end. Remove sleeve washer at the impeller hub.
3. Remove gland side liner (rubber-lined 2-174-0) from the casing.
4. Remove gland (6-014-0). Slide deflector (5-024-3) back toward stuffing box.
5. Drain oil from pedestal reservoir by removing side pipe plug.
6. Remove bearing housing adjusting bolts and nuts at outboard end. Remove shaft (5-007-0), bearings (5-026-3 and 5-026-4) and bearing housing (5-025-4) from the pedestal (5-083-0) using a drift pin and hammer or a hydraulic press if available.
7. Remove packing (6-924-0) from casing. Remove half seal cage (6-013-0) and bushing (6-519-0). Note the order in which parts are removed in this arrangement. See page 2 for stuffing box arrangement A or B. Remove shaft sleeves (1-009-0) and (1-009-1) by sliding them off the shaft. Remove O-ring. Remove deflector (5-024-3).
8. Place shaft assembly in bench vise and remove bearing retaining ring (5-068-4). Clean shaft before removing bearing housing. Slide bearing housing (5-025-4) from outboard bearing. Remove O-ring. Now bearing seal (5-177-4) may be inspected and removed if necessary. Remove bearing retaining ring (5-086-4).
9. Remove inboard and outboard bearings (5-026-3) and (5-026-4) from shaft using a hydraulic press or suitable bearing puller.
10. Remove bearing cover (5-018-3) and accompanying gasket (5-409-3). Now bearing seal (5-177-3) may be inspected and removed if necessary.
1. Mount bearings (5-026-3) and (5-026-4) on shaft (shrink fit) by first heating them in hot oil at approximately 150° F (66° C) for sufficient expansion. In mounting, inner race of bearings must contact shaft shoulder. Replace bearing retaining ring (5-086-4). Dry cool bearings to room temperature.
2. Locate O-ring on outside diameter of bearing housing (5-025-4) and fit bearing seal (5-177-4) in bearing housing. Slide bearing housing over outboard bearing (5-026-4) and replace bearing retaining ring (5-086-4).
3. Mount bearing seal (5-177-3) in bearing cover (5-018-3). Replace gasket (5-409-3). Bolt bearing cover to pedestal (5-083-0).
4. Assemble shaft, bearings and bearing housing into pedestal making sure that deflector (5-024-3), seal cage (6-013-0) and waterseal bushing (6-519-0) are located on shaft between stuffing box and bearing cover during assembly. Fit adjusting bolts and nuts at outboard end to bearing housing and pedestal.
5. Assemble shaft sleeve (spacer) (1-009-1) and shaft sleeve (stuffing box) (1-009-0) with O-rings, on the shaft. Locate deflector (5-024-3) on shaft sleeve (spacer). Make sure that deflector does not rub against bearing cover.
6. Install waterseal busing (6-519-0) and half seal cage (6-013-0) into stuffing box. Replace packing (6-924-0) and gland (6-014-0). Check if waterseal bushing is concentric with sleeve.
7. Replace gland side liner (2-174-0). Do not use excessive force on liner stud nuts.
8. Locate sleeve washer and O-ring on shaft at shaft sleeve (1-009-0) and then screw on impeller (4-002-0).
9. Replace suction side liner (2-174-5). Do not use excessive force on liner stud nuts. Bolt two half casings together. Check liner stud nuts for tightness.
10. *See impeller clearance adjustment.* After clearance is established secure locking nuts.
11. Fill pedestal reservoir with oil to proper level and pack bearing cover and bearing housing seals with high temperature grease through connections provided. See LUBRICATION page 2.
12. Reconnect suction and discharge piping.

ASSEMBLY PROCEDURE

IMPORTANT - It is essential that all parts be thoroughly cleaned before reassembly. When handling rotating element and bearings, maintain a clean and dust free environment. Do not unwrap new bearings prior to their installation. New bearings are coated with a rust preventative having good lubricating qualities. This coating should not be removed unless the bearings have become dirty while in storage.

IMPELLER CLEARANCE ADJUSTMENT

1. Adjust impeller clearance by means of adjusting bolt and nut located at outboard end.
2. Move the bearing assembly forward until the impeller touches the suction side liner. This is tested by rotating the shaft by hand.
3. The bearing assembly should then be brought back 1/16" so that the impeller will not rub on suction liner.
4. Check the rotating element by hand for freedom of rotation.
5. Tighten locking nut on adjusting bolt. By making this adjustment periodically (depending on the rate of wear) original pump efficiency can be maintained.

SECTIONAL ASSEMBLY and PARTS LIST 3x3x10, 5x5x14, 6x6x15 SRL & 3x3x10 & 5x4x14 SRL-C

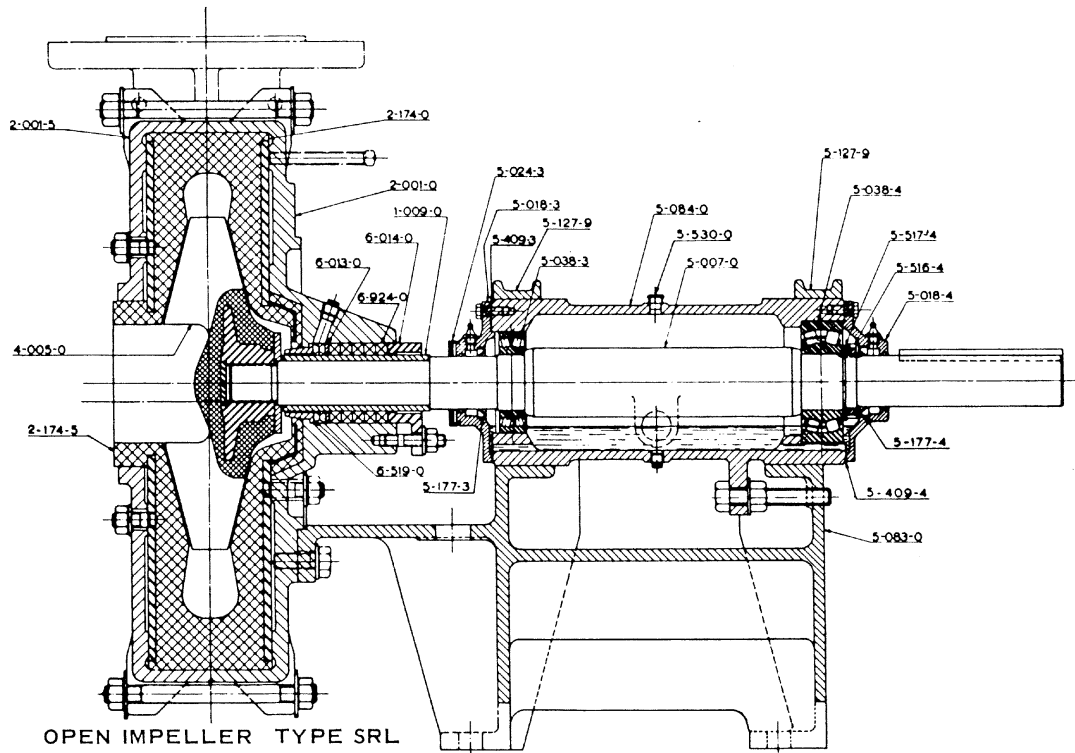

OPEN IMPELLER TYPE SRL

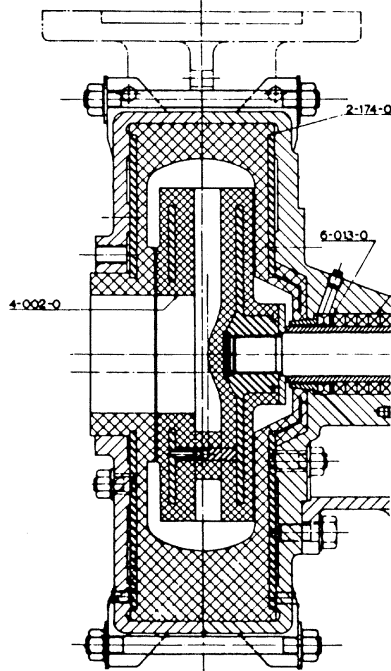

CLOSED IMPELLER
TYPE SRL-C

<i>Cat No.</i>	<i>Description</i>	<i>Cat No.</i>	<i>Description</i>
1-009-0	Shaft Sleeve	5-084-0	Bearing Cylinder
2-001-0	Gland Half Casing	5-127-9	Bearing Cylinder Strap
2-001-5	Suction Half Casing	5-177-3	Bearing Seal (Inb.)
2-174-0	Gland Side Liner	5-177-4	Bearing Seal (Outb.)
2-174-5	Suction Side Liner	5-409-3	Brg. Cov. Gasket (Inb.)
4-002-0	Impeller (Closed)	5-409-4	Brg. Cov. Gasket (Outb.)
4-005-0	Impeller (Open)	5-516-4	Bearing Locknut
5-007-0	Shaft	5-517-4	Bearing Lockwasher
5-018-3	Bearing Cover (Inb.)	5-530-0	Oil Filler Cap With Vent
5-018-4	Bearing Cover (Outb.)	6-013-0	Half Seal Cage
5-024-3	Deflector	6-014-0	Gland
5-038-3	Roller Bearing (Inb.)	6-519-0	Waterseal Bushing
5-038-4	Roller Bearing (Outb.)	6-924-0	Packing
5-083-0	Pedestal		

3x3x10, 5x5x14, 6x6x15 SRL 3x3x10 & 5x4x14 SRL-C

DISMANTLING PROCEDURE

1. Open casing by removing a section of the suction pipe, breaking discharge pipe connection, supporting discharge pipe and loosening and removing the bolts holding the casing halves together while making sure suction side casing is properly supported from dropping. Suction half casing (2-001-5) can then be removed. The suction side liner (rubber-lined 2-174-5) may be removed by using jackscrews provided for that purpose.
2. Impeller (4-002-0 or 4-005-0) is mounted with a right hand thread. Rotation is clockwise when viewed from the pump drive end. To remove the impeller, hold the shaft to keep it from rotating and pound on a hardwood block held against the impeller vane at the periphery in the counterclockwise direction when viewed from the impeller end. Remove sleeve washer at the impeller hub.
3. Remove gland side liner (rubber-lined 2-174-0) from the casing.
4. Remove gland (6-014-0). Remove shaft sleeve (1-009-0) by prying it loose at stuffing box and sliding it off the shaft. Remove sleeve O-ring.
5. Remove both bearing cylinder straps (5-127-9).
6. Drain oil from bearing cylinder (5-084-0) by removing the bottom pipe plug.
7. Remove adjusting screw mechanism which includes cotter pin, castle nut and washer. Then rotate bearing cylinder assembly so that the cylinder lug does not foul pedestal (5-083-0) when removing the bearing cylinder assembly.
8. Place the bearing cylinder assembly on work bench and, if possible, hold the cylinder in a fixed position.
9. Remove packing (6-924-0), half seal cage (6-013-0) and waterseal bushing (6-6-519-0) from the casing. Note the order in which parts are removed in this arrangement. See page 2 for stuffing box arrangement A or B.
10. Remove deflector (5-024-3) from the shaft. Remove inboard bearing cover (5-018-3) and accompanying gasket (5-409-3). Now bearing seal (5-177-3) may be inspected and removed if necessary.
11. With sheave and key removed from the shaft, the outboard bearing cover (5-018-4) will slide off the shaft after removal of bolts. Clean shaft before removing bearing cover. Remove accompanying gasket (5-409-4). Now bearing seal (5-177-4) may be inspected and removed if necessary.
12. Remove shaft (5-007-0) and bearing (5-038-3 and 5-038-4) from the bearing cylinder using a drift pin and hammer or a hydraulic press if available.
13. Remove bearing locknut (5-516-4) and lockwasher (5-517-4). Remove bearings by using a hydraulic press or suitable bearing puller.
1. Mount bearings (5-038-3 and 5-038-4) on shaft (shrink fit) by first heating them in hot oil at approximately 150° F (66° C) for sufficient expansion. In mounting inner race of bearings must contact shaft shoulder. Dry cool bearings to room temperature.
2. Assemble locknut (5-516-4) and lockwasher (5-517-4).
3. Assemble shaft and bearings into cylinder or frame liner (5-084-0). This can be done either horizontally or vertically. In each case inboard bearing (5-038-3) outer race must be parallel and square to shaft when assembling. Shaft must be held securely when guiding into cylinder while taking care not to damage shaft surfaces.
4. Mount seals (5-177-4 and 5-177-3) in bearing covers (5-018-4 and 5-018-3). Replace gaskets (5-409-4 and 5-409-3). Install deflector (5-024-3).
5. Install water seal bushing (6-519-0) and half seal cage (6-013-0) into stuffing box.
6. Place bearing cylinder or frame liner on pedestal (5-083-0) and bolt bearing cylinder straps (5-127-9) into place. Leave bolts slightly loose for later adjustment, step 11. Reassemble adjusting screw mechanism.
7. Mount shaft sleeve (1-009-0). Replace packing (6-924-0) and gland (6-014-0). Check if waterseal bushing (5-519-0) is concentric with sleeve.
8. Replace gland side liner (2-174-0). Do not use excessive force on liner stud nuts.
9. Locate sleeve washer and O-ring on shaft at shaft sleeve (1-009-0) and then screw on impeller (4-002-0 or 4-005-0).
10. Replace suction side liner (2-174-5). Do not use excessive force on liner stud nuts. Bolt two half casings together. Check liner stud nuts for tightness.
11. *See impeller clearance adjustment.* After clearance is established secure all bolts on bearing cylinder straps.
12. Reconnect suction and discharge piping.
13. Fill cylinder or frame liner with oil to proper level and pack both bearing cover seals with high temperature grease through grease connections provided. See LUBRICATION, page 2.

ASSEMBLY PROCEDURE

IMPORTANT - It is essential that all parts be thoroughly cleaned before reassembly. When handling rotating element and bearings, maintain a clean and dust-free environment. Do not unwrap new bearings prior to their installation. New bearings are coated with a rust preventative having good lubricating qualities. This coating should not be removed unless the bearings have become dirty while in storage.

IMPELLER CLEARANCE ADJUSTMENT

1. Loosen the bolts clamping down the bearing cylinder or frame liner straps.
2. By means of the adjusting screw, move the bearing cylinder forward until the impeller touches the suction side liner. This is tested by rotating the shaft by hand.
3. The bearing cylinder or frame liner should then be brought back 1/16" so that the impeller will not rub on suction liner.
4. Check the rotating element by hand for freedom of rotation.
5. Retighten bearing cylinder straps. By making this adjustment periodically (depending on the rate of wear) original pump efficiency can be maintained.

SECTIONAL ASSEMBLY and PARTS LIST 8x6x18 and 10x8x21 SRL-C

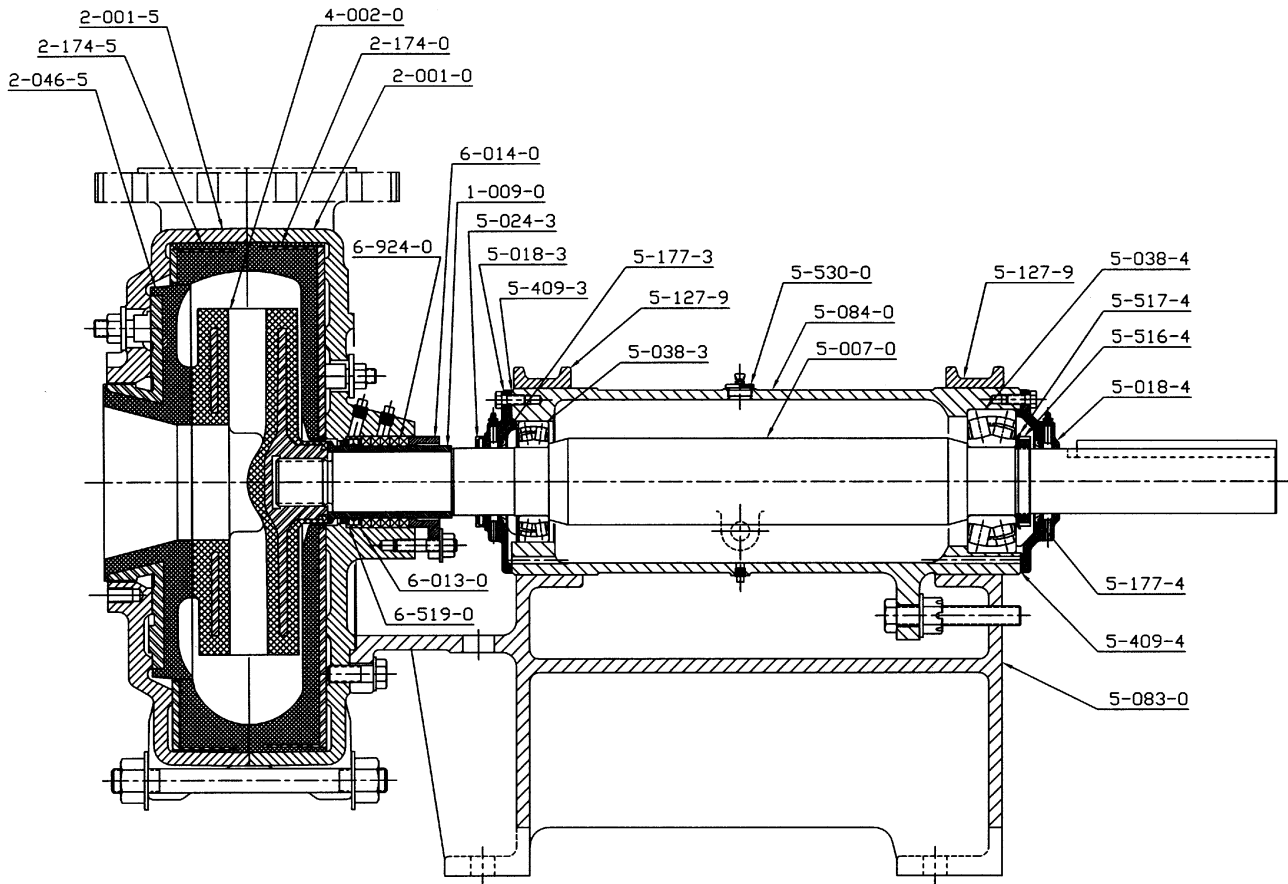

Cat No.	Description	Cat No.	Description	Cat No.	Description
1-009-0	Shaft Sleeve	5-018-4	Bearing Cover (Outb.)	5-409-3	Bearing Cover Gasket (Inb.)
2-001-0	Gland Half Casing	5-024-3	Deflector	5-409-4	Bearing Cover Gasket (Outb.)
2-001-5	Suction Half Casing	5-038-3	Roller Bearing (Inb.)	5-516-4	Bearing Locknut
2-046-5	Casing Sideplate	5-038-4	Roller Bearing (Outb.)	5-517-4	Bearing Lockwasher
2-174-0	Gland Side Liner	5-083-0	Pedestal	5-530-0	Oil Filler Cap With Vent
2-174-5	Suction Side Liner	5-084-0	Bearing Cylinder	6-013-0	Half Seal Cage
4-002-0	Impeller	5-127-9	Bearing Cylinder Strap	6-014-0	Gland
5-007-0	Shaft	5-177-3	Bearing Seal (Inb.)	6-519-0	Waterseal Bushing
5-018-3	Bearing Cover (Inb.)	5-177-4	Bearing Seal (Outb.)	6-924-0	Packing

8x6x18 and 10x8x21 SRL-C

DISMANTLING PROCEDURE

1. Open casing by removing a section of the suction pipe, breaking discharge pipe connection, supporting discharge pipe and loosening and removing the bolts holding the casing halves together while making sure suction side casing is properly supported from dropping. Suction half casing (2-001-5) can then be removed. Remove casing sideplate (2-046-5). The suction side liner (rubber-lined 2-174-5) may be removed by using jackscrews provided for that purpose.
2. Impeller (4-002-0) is mounted with a right hand thread. Rotation is clockwise when viewed from the pump drive end. To remove the impeller, hold the shaft to keep it from rotating and pound on a hardwood block held against the impeller vane at the periphery in the counterclockwise direction when viewed from the impeller end.
3. Remove gland side liner (rubber-lined 2-174-0) from the casing.
4. Remove gland (6-014-0). Remove shaft sleeve (1-009-0) by prying it loose at stuffing box and sliding it off the shaft. Remove sleeve O-ring.
5. Remove both bearing cylinder straps (5-127-9).
6. Drain oil from bearing cylinder (5-084-0) by removing the bottom pipe plug.
7. Remove adjusting screw mechanism which includes cotter pin, castle nut and washer. Then rotate bearing cylinder assembly so that the cylinder lug does not foul pedestal (5-083-0) when removing the bearing cylinder assembly.
8. Place the bearing cylinder assembly on work bench and, if possible, hold the cylinder in a fixed position.
9. Remove packing (6-924-0), half seal cage (6-013-0) and waterseal bushing (6-519-0) from the casing. Note the order in which parts are removed in this arrangement. See page 2 for stuffing box arrangement A or B.
10. Remove deflector (5-024-3) from the shaft. Remove inboard bearing cover (5-018-3) and accompanying gasket (5-409-3). Now bearing seal (5-177-3) may be inspected and removed if necessary.
11. With sheave and key removed from the shaft, the outboard bearing cover (5-018-4) will slide off the shaft after removal of bolts. Clean shaft before removing bearing cover. Remove accompanying gasket (5-409-4). Now bearing seal (5-177-4) may be inspected and removed if necessary.
12. Remove shaft (5-007-0) and bearings (5-038-3 and 5-038-4) from the bearing cylinder using a drift pin and hammer or a hydraulic press if available.
13. Remove bearing lockout (5-516-4) and lockwasher (5-517-4). Remove bearings by using a hydraulic press or suitable bearing puller.

ASSEMBLY PROCEDURE

IMPORTANT - It is essential that all parts be thoroughly cleaned before reassembly. When handling rotating element and bearings, maintain a clean and dust-free environment. Do not unwrap new bearings prior to their installation. New bearings are coated with a rust preventative having good lubricating qualities. This coating should not be removed unless the bearings have become dirty while in storage.

1. Mount bearings (5-038-3 and 5-038-4) on shaft (shrink fit) by first heating them in hot oil at approximately 150° F (66° C) for sufficient expansion. In mounting inner race of bearings must contact shaft shoulder. Dry cool bearings to room temperature.
 2. Assemble locknut (5-516-4) and lockwasher (5-517-4).
 3. Assemble shaft and bearings into cylinder or frame liner (5-084-0). This can be done either horizontally or vertically. In each case inboard bearing (5-038-3) outer race must be parallel and square to shaft when assembling. Shaft must be held securely when guiding into cylinder while taking care not to damage shaft surfaces.
 4. Mount seals (5-177-4 and 5-177-3) in bearing covers (5-018-4 and 5-018-3). Replace gaskets (5-409-4 and 5-409-3). Install deflector (5-024-3).
 5. Install waterseal bushing (6-519-0) and half seal cage (6-013-0) into stuffing box.
 6. Place bearing cylinder or frame liner on pedestal (5-083-0) and bolt bearing cylinder straps (5-127-9) into place. Leave bolts slightly loose for later adjustment, step 11.
- Reassemble adjusting screw mechanism.
7. Mount shaft sleeve (1-009-0). Replace packing (6-924-0) and gland (6-014-0). Check if waterseal bushing (6-519-0) is concentric with sleeve.
 8. Replace gland side liner (2-174-0). Do not use excessive force on liner stud nuts.
 9. Screw on impeller (4-002-0).
 10. Replace suction side liner (2-174-5). Replace casing sideplate (2-046-5). Do not use excessive force on casing sideplate stud nuts. Bolt two half casings together. Check casing sideplate stud nuts for tightness.
 11. *See impeller clearance adjustment.* After clearance is established, secure all bolts on bearing cylinder straps.
 12. Reconnect suction and discharge piping.
 13. Fill cylinder or frame liner with oil to proper level and pack both bearing cover seals with high temperature grease through connections provided. See LUBRICATION, page 2.

IMPELLER CLEARANCE ADJUSTMENT

1. Loosen the bolts clamping down the bearing cylinder or frame liner straps.
2. By means of the adjusting screw, move the bearing cylinder forward until the impeller touches the suction side liner. This is tested by rotating the shaft by hand.
3. The bearing cylinder or frame liner should then be brought back 1/16" so that the impeller will not rub on suction liner.
4. Check the rotating element by hand for freedom of rotation.
5. Retighten bearing cylinder straps. By making this adjustment periodically (depending on the rate of wear) original pump efficiency can be maintained.

SECTIONAL ASSEMBLY and PARTS LIST 12x10x25 SRL-C

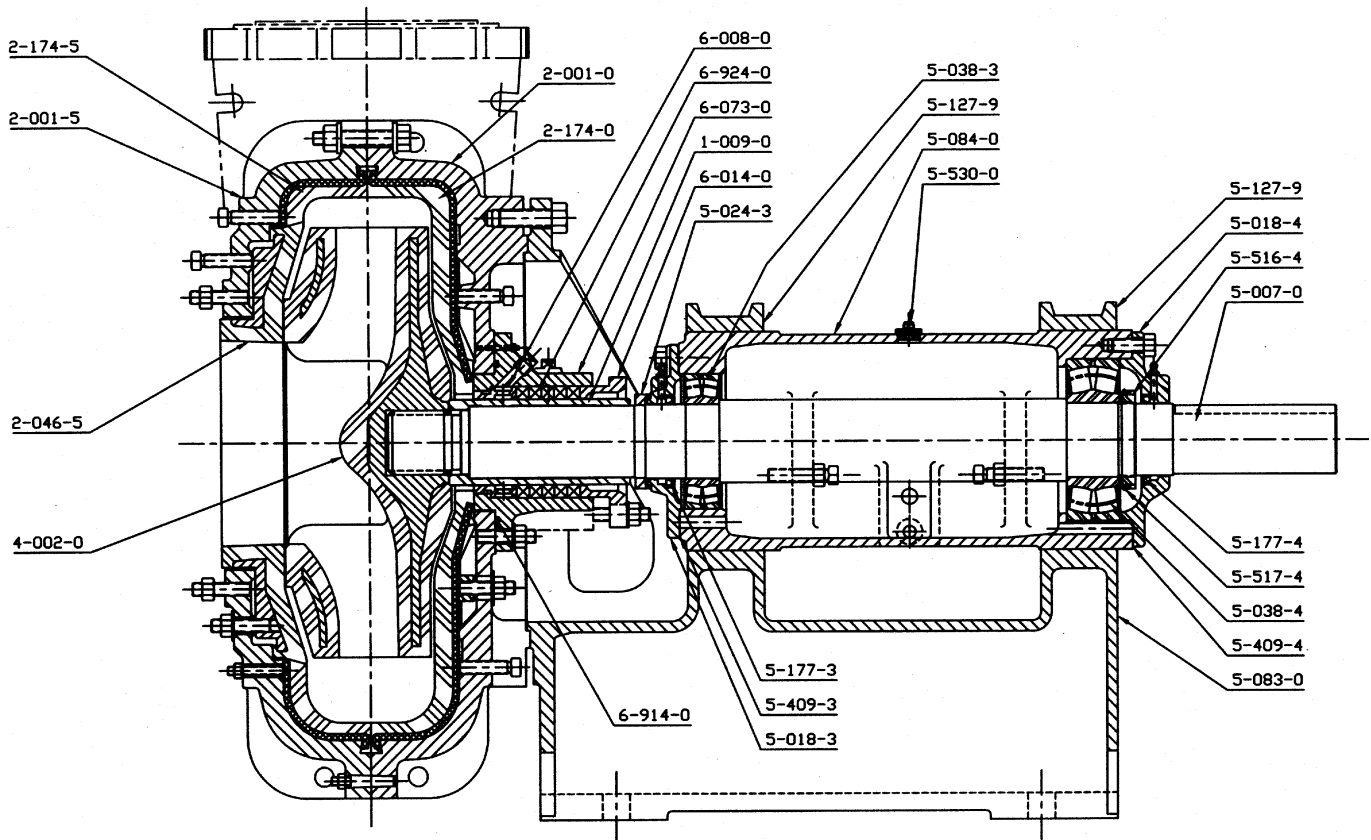

Cat No.	Description	Cat No.	Description	Cat No.	Description
1-009-0	Shaft Sleeve	5-024-3	Water Slinger	5-409-4	Gasket Brg. Cov. (Outb.)
2-001-0	Gland Half Casing	5-038-3	Roller Bearing (Inb.)	5-516-4	Bearing Locknut
2-001-5	Suction Half Casing	5-038-4	Roller Bearing (Outb.)	5-517-4	Bearing Lockwasher
2-046-5	Casing Sideplate	5-083-0	Pedestal	5-530-0	Oil Filler Cap With Vent
2-174-0	Gland Side Liner	5-084-0	Bearing Cylinder	6-008-0	Waterseal Bushing
2-174-5	Suction Side Liner	5-127-0	Bearing Cylinder Strap	6-014-0	Gland
4-002-0	Impeller	5-177-3	Bearing Seal (Inb.)	6-073-0	Stuffing Box
5-007-0	Shaft	5-177-4	Bearing Seal (Outb.)	6-914-0	O-ring Stuffing Box
5-018-3	Bearing Cover (Inb.)	5-409-3	Gasket Brg. Cover (Inb.)	6-924-0	Packing
5-018-4	Bearing Cover (Outb.)				

12x10x25 SRL-C

DISMANTLING PROCEDURE

1. Open casing by removing a section of the suction pipe, breaking discharge pipe connection, supporting discharge pipe and loosening and removing the bolts holding the casing halves together while making sure suction side casing is properly supported from dropping. Suction half casing (2-001-5) can then be removed. Remove suction sideplate (2-046-5) by using jackscrews provided for that purpose. The suction side liner (2-174-5) may be removed by using jackscrews provided for that purpose.
2. Impeller (4-002-0) is mounted with a right hand thread. Rotation is clockwise when viewed from the pump drive end. To remove the impeller, hold the shaft to keep it from rotating and apply an adequate shock load on impeller in a counterclockwise direction (viewed from impeller end) to unscrew it.
3. Remove gland (6-014-0). Remove shaft sleeve (1-009-0) by sliding it off the shaft.
4. Remove gland side liner (2-174-0) by using jackscrews provided for that purpose.
5. Remove both bearing cylinder straps (5-127-0).
6. Drain oil from bearing cylinder (5-084-0) by removing side pipe plug.
7. Loosen adjusting screws. Then rotate bearing cylinder assembly so that the cylinder lugs do not foul pedestal (5-083-0) when removing the bearing cylinder assembly.
8. Place the bearing cylinder assembly on work bench and, if possible, hold it in a fixed position.
9. Remove packing (6-924-0) and water seal bushing (6-008-0) from the casing. Note the order in which parts are removed in this arrangement. See page 2 for stuffing box arrangement A or B.
10. The stuffing box (6-073-0) normally would not be removed. If necessary, it can be removed by unscrewing retaining nuts and removing the tapered dowel pins. Remove O-ring (6-914-0).
11. Remove water slinger (5-024-3). Remove inboard bearing cover (5-018-3) and accompanying gasket (5-409-3). Remove cover carefully so as not to damage bearing seal. Now bearing seal (5-177-3) may be inspected and removed if necessary.
12. With key removed from the shaft, the outboard bearing cover (5-018-4) will slide off the shaft after removal of bolts. Clean shaft before removing bearing cover. Remove accompanying gasket (5-409-4). Now bearing cover seal (5-177-4) may be inspected and removed if necessary.
13. Remove shaft (5-007-0) and bearings (5-038-3 and 5-038-4) from the bearing cylinder by supporting shaft and pushing or pulling it out from the cylinder. Take care not to damage shaft surfaces.
14. Remove inboard roller bearing (5-038-3) by using a suitable bearing puller. Remove locknut (5-516-4) and lockwasher (5-517-4). Remove outboard roller bearing (5-038-4) by using a suitable bearing puller.
1. Mount bearings (5-038-3 and 5-038-4) on shaft (shrink fit) by first heating them in hot oil at approximately 150° F (66° C) for sufficient expansion. In mounting inner race of bearings must contact shaft shoulder. Dry cool bearings to room temperature.
2. Assemble locknut (5-516-4) and lockwasher (5-517-4).
3. Assemble shaft and bearings into cylinder or frame liner (5-084-0). This can be done either horizontally or vertically. In each case inboard bearing (5-038-3) outer race must be parallel and square to shaft when assembling. Shaft must be held securely when guiding into cylinder while taking care not to damage shaft surfaces.
4. Mount seals (5-177-4 and 5-177-3) in bearing covers (5-018-4 and 5-018-3). Replace gaskets (5-409-4 and 5-409-3). Install deflector (5-024-3).
5. If required, install stuffing box (6-073-0) with O-ring (6-914-0) at this time. Replace taper dowels. Install water seal bushing (6-008-0).
6. Place bearing cylinder (5-084-0) on pedestal (5-083-0) and bolt straps (5-127-0) into place. Leave bolts slightly loose for later adjustment, step 10.
7. Install gland side liner (2-174-0). Mount shaft sleeve (1-009-0). Replace packing (6-924-0) and gland (6-014-0).
8. Screw on impeller (4-002-0).
9. Replace suction side liner (2-174-5) and then suction sideplate (2-046-5). Bolt two half casings together. Check sideplate stud nuts for tightness.
10. *See impeller clearance adjustment.* After clearance is established secure all bolts on bearing cylinder straps. Secure adjusting screws.
11. Reconnect suction and discharge piping.
12. Fill bearing cylinder with oil using oil cap (5-530-0) to proper level (see sight glass). Cylinder must be horizontal and level so that both sight glass oil readings are identical. Pack both bearing cover seals with high temperature grease through grease fittings. See LUBRICATION, page 2.

IMPELLER CLEARANCE ADJUSTMENT

1. Loosen the bolts clamping down the bearing cylinder or frame liner straps.
2. By means of the adjusting screw, move the bearing cylinder forward until the impeller touches the suction side liner. This is tested by rotating the shaft by hand.
3. The bearing cylinder or frame liner should then be brought back .040" so that the impeller will not rub on suction liner.
4. Check the rotating element by hand for freedom of rotation.
5. Retighten bearing cylinder straps. By making this adjustment periodically (depending on the rate of wear) original pump efficiency can be maintained.

ASSEMBLY PROCEDURE

IMPORTANT - It is essential that all parts be thoroughly cleaned before reassembly. When handling rotating element and bearings, maintain a clean and dust-free environment. Do not unwrap new bearings prior to their installation. New bearings are coated with a rust preventative having good lubricating qualities. This coating should not be removed unless the bearings have become dirty while in storage.

SECTIONAL ASSEMBLY and PARTS LIST 14x12x29 SRL-C

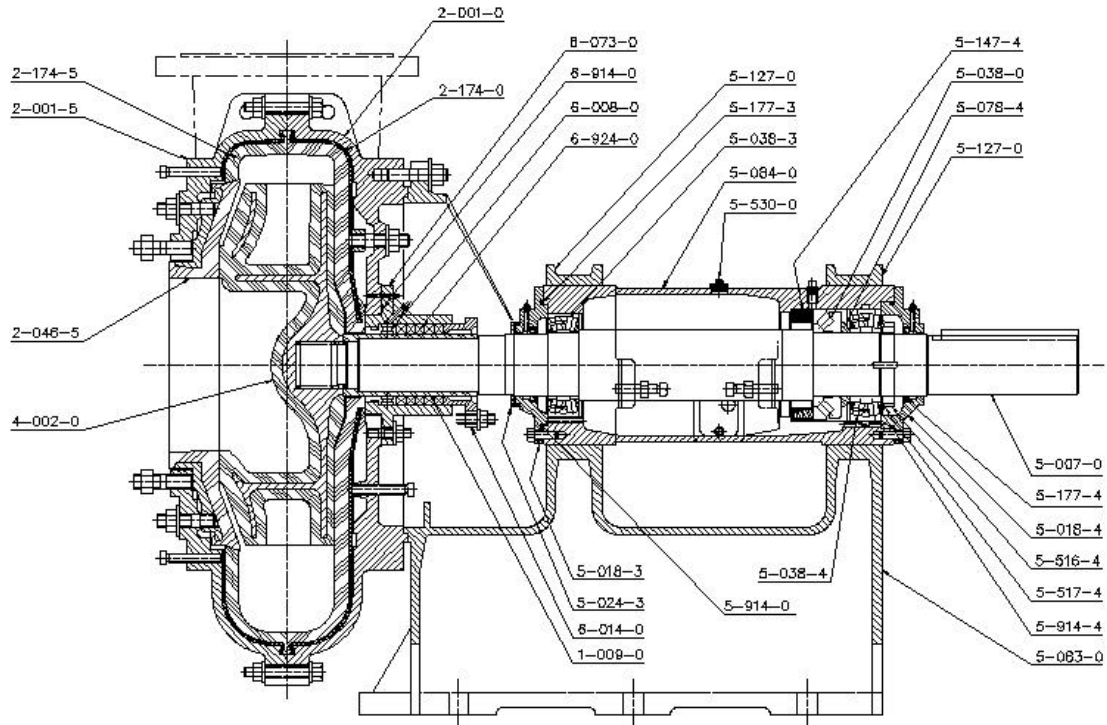

14x12x29 SRL-C
MAY 12/99

Cat No.	Description	Cat No.	Description	Cat No.	Description
1-009-0	Shaft Sleeve	5-038-0	Thrust Bearing	5-516-4	Bearing Locknut
2-001-0	Gland Half Casing	5-038-3	Roller Bearing (Inb.)	5-517-4	Bearing Lockwasher
2-001-5	Suction Half Casing	5-038-4	Roller Bearing (Inb.)	5-530-0	Oil Filler Cap With Vent
2-046-5	Casing Sideplate	5-078-4	Bearing Spacer	5-914-3	O-ring Bearing Cover
2-174-0	Gland Side Liner	5-083-0	Pedestal	5-914-4	O-ring Bearing Cover
2-174-5	Suction Side Liner	5-084-0	Bearing Cylinder	6-008-0	Water Seal Bushing
4-002-0	Impeller	5-127-0	Bearing Cylinder Strap	6-014-0	Gland
5-007-0	Shaft	5-147-4	Spacer	6-073-0	Stuffing Box
5-018-3	Bearing Cover (Inb.)	5-177-3	Bearing Seal (Inb.)	6-914-9	O-ring Stuffing Box
5-018-4	Bearing Cover (Outb.)	5-177-4	Bearing Seal (Outb.)	6-924-0	Packing
5-024-3	Water Slinger				

14x12x29 SRL-C

DISMANTLING PROCEDURE

1. Open casing by removing a section of the suction pipe, breaking discharge pipe connection, supporting discharge pipe and loosening and removing the bolts holding the casing halves together while making sure suction side casing is properly supported from dropping. Suction half casing (2-001-5) can then be removed. Remove suction sideplate (2-046-5) by using jackscrews provided for that purpose. The suction side liner (2-174-5) may be removed.
 2. Impeller (4-002-0) is mounted with a right hand thread. Rotation is clockwise when viewed from the pump drive end. To remove the impeller, hold the shaft to keep it from rotating and apply an adequate shock load on impeller in a counterclockwise direction (viewed from impeller end) to unscrew it.
 3. Remove gland (6-014-0). Remove shaft sleeve (1-009-0) by sliding it off the shaft.
 4. Remove gland side liner (2-174-0).
 5. Remove both bearing cylinder straps (5-127-0).
 6. Drain oil from bearing cylinder (5-084-0) by removing side pipe plug.
 7. Loosen adjusting screws. Then rotate bearing cylinder assembly so that the cylinder lugs do not foul pedestal (5-083-0) when removing the bearing cylinder assembly.
 8. Place the bearing cylinder assembly on work bench and, if possible, hold it in a fixed position.
 9. Remove packing (6-924-0) and water seal bushing (6-008-0) from the casing. Note the order in which parts are removed in this arrangement. See page 2 for stuffing box arrangement A or B.
 10. The stuffing box (6-073-0) normally would not be removed. If necessary, it can be removed by unscrewing retaining nuts and removing the tapered dowel pins. Remove O-ring (6-914-0).
 11. Remove water slinger (5-024-3). Remove inboard bearing cover (5-018-3) and accompanying O-ring (5-914-3). Remove cover carefully so as not to damage bearing seal. Now bearing seal (5-177-3) may be inspected and removed if necessary.
 12. With key removed from the shaft, the outboard bearing cover (5-018-4) will slide off the shaft after removal of bolts. Clean shaft before removing bearing cover. Remove accompanying O-ring (5-914-4). Now bearing cover seal (5-177-4) may be inspected and removed if necessary.
 13. Remove shaft (5-007-0) and bearing assemblies from the bearing cylinder by supporting shaft and pushing or pulling it out from the cylinder. Take care not to damage shaft surfaces.
 14. Remove inboard roller bearing (5-038-3) by using a suitable bearing puller. Remove locknut (5-516-4) and lockwasher (5-517-4). Remove outboard roller bearing (5-038-4) by using a suitable bearing puller. Remove bearing spacer (5-078-4). Remove thrust bearing (5-038-0) by using a suitable bearing puller. Now remove spring retainer (5-147-4) and accompanying springs.
1. Mount inboard roller bearing (5-038-3) on shaft (shrink fit) by first heating it in hot oil at approximately 150° F (66° C) for sufficient expansion. In mounting, inner race of bearing must contact shaft shoulder. Dry cool bearing to room temperature.
 2. Place spring retainer (5-147-4) on shaft. Mount thrust bearing spacer ring on shaft (5-007-0) so as to contact shoulder. Mount thrust bearing (5-038-0) on shaft (shrink fit) by first heating it in hot oil at approximately 150° F (66° C) for sufficient expansion. In mounting, inner race of bearing must contact spacer ring. Dry cool bearing to room temperature.
 3. Mount bearing spacer (5-078-4) with largest diameter adjacent to thrust bearing. Mount outboard roller bearing (5-038-4) using the same method as the thrust bearing (5-038-0). Inner race of bearing must contact spacer.
 4. Mount lockwasher (5-517-4) and locknut (5-516-4). During assembly of shaft and bearings into cylinder (5-084-0) place springs into spring retainer (5-147-4) and align retainer with outer race of thrust bearing (5-038-0) so that both will enter bearing cylinder bore during assembly sequence. Also ensure that inboard bearing (5-038-3) outer race is parallel and square to shaft at assembly. Put shaft and bearings into cylinder.
 5. Assemble bearing seal (5-177-4) and O-ring (5-914-4) in cover (5-018-4) and mount to bearing cylinder (5-084-0). After tightening screws an axial clearance of .004" - .015" between outer race of thrust bearing (5-038-0) and spring retainer (5-147-4) should exist. Check this clearance by using hole on top of bearing cylinder.
 6. Mount bearing seal (5-177-3) and O-ring (5-914-3) in cover (5-018-3) and bolt to bearing cylinder. Mount water slinger (5-024-3).
 7. If required, install stuffing box (6-073-0) with O-ring (6-914-0) at this time. Replace taper dowels. Install water seal bushing (6-008-0).
 8. Place bearing cylinder (5-084-0) on pedestal (5-083-0) and bolt straps (5-127-0) into place. Leave bolts slightly loose for later adjustment, step 12.
 9. Install gland side liner (2-174-0). Mount shaft sleeve (1-009-0). Replace packing (6-924-0) and gland (6-014-0).
 10. Screw on impellers (4-002-0).
 11. Replace suction side liner (2-174-5) and then suction sideplate (2-046-5). Bolt two half casings together. Check sideplate stud nuts for tightness.
 12. *See impeller clearance adjustment.* After clearance is established secure all bolts on bearing cylinder straps. Secure adjusting screws.
 13. Reconnect suction and discharge piping.
 14. Fill bearing cylinder with oil using oil cap (5-030-0) to proper level (see sight glass). Cylinder must be horizontal and level so that both sight glass oil readings are identical. Pack both bearing cover seals with high temperature grease through grease fittings. See LUBRICATION, page 2.

ASSEMBLY PROCEDURE

IMPORTANT - It is essential that all parts be thoroughly cleaned before assembly. When handling rotating element and bearings, maintain a clean and dust-free environment. Do not unwrap new bearings prior to their installation. New bearings are coated with a rust preventive having good lubricating qualities. This coating should not be removed unless the bearings have become dirty while in storage.

IMPELLER CLEARANCE ADJUSTMENT

1. Loosen the bolts clamping down the bearing cylinder or frame liner straps.
2. By means of the adjusting screw, move the bearing cylinder forward until the impeller touches the suction side liner. This is tested by rotating the shaft by hand.
3. The bearing cylinder or frame liner should then be brought back .040" so that the impeller will not rub on suction liner.
4. Check the rotating element by hand for freedom of rotation.
5. Retighten bearing cylinder straps. By making this adjustment periodically (depending on the rate of wear) original pump efficiency can be maintained.

SECTIONAL ASSEMBLY and PARTS LIST 16x14x34 SRL-C

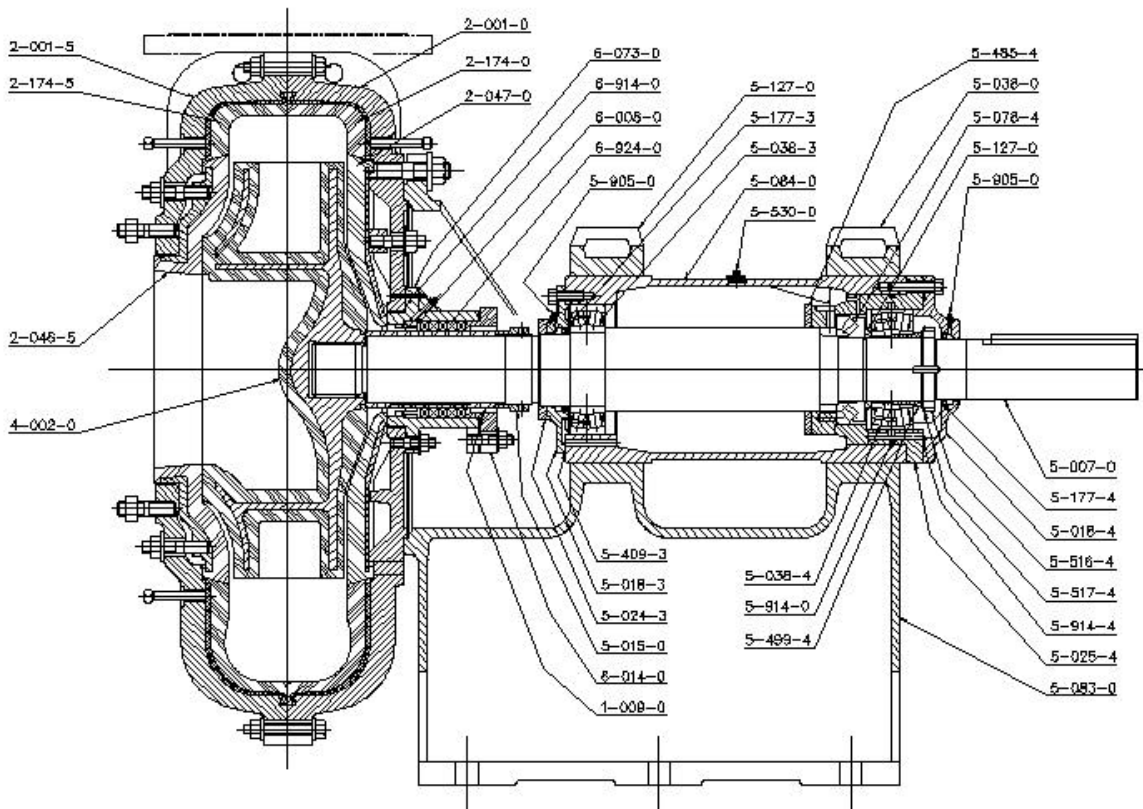

16x14x34 SRL-C
MAY 7/88

Cat No.	Description	Cat No.	Description	Cat No.	Description
1-009-0	Shaft Sleeve	5-025-4	Bearing Housing	5-516-4	Bearing Locknut
2-001-0	Gland Half Casing	5-038-0	Thrust Bearing	5-517-4	Bearing Lockwasher
2-001-5	Suction Half Casing	5-038-3	Roller Bearing (Inb.)	5-530-0	Oil Filler Cap With Vent
2-047-5	Rear Sideplate	5-038-4	Roller Bearing (Outb.)	5-914-0	O-ring Brg. Cover
2-046-5	Suction Sideplate	5-078-4	Bearing Spacer	5-914-4	O-ring Brg. Cover
2-174-0	Gland Side Liner	5-083-0	Pedestal	5-905-0	Grease Fitting
2-174-5	Suction Side Liner	5-084-0	Bearing Cylinder	6-008-0	Water Seal Bushing
4-002-0	Impeller	5-127-0	Bearing Cylinder Strap	6-014-0	Gland
5-007-0	Shaft	5-177-3	Bearing Seal (Inb.)	6-073-0	Stuffing Box
5-015-0	Shaft Sleeve Nut	5-177-4	Bearing Seal (Outb.)	6-914-9	O-ring Stuffing Box
5-018-3	Bearing Cover (Inb.)	5-409-3	Gasket Brg, Cov. (Inb.)	6-924-0	Packing
5-018-4	Bearing Cover (Outb.)	5-485-4	Oil Slinger		
5-024-3	Water Slinger	5-499-4	Bearing Sleeve		

16x14x34 SRL-C

DISMANTLING PROCEDURE

1. Open casing by removing a section of the suction pipe, breaking discharge pipe connection, supporting discharge pipe and loosening and removing the bolts holding the casing halves together while making sure suction side casing is properly supported from dropping. Suction half casing (2-001-5) can then be removed. Remove suction sideplate (2-046-5) by using jackscrews provided for that purpose. The suction side liner (2-174-5) may be removed.
2. Impeller (4-002-0) is mounted with a right hand thread. Rotation is clockwise when viewed from the pump drive end. To remove the impeller, hold the shaft to keep it from rotating and apply an adequate shock load on impeller in a counterclockwise direction (viewed from impeller end) to unscrew it.
3. Remove gland (6-014-0). Remove shaft sleeve (1-009-0) by sliding it off the shaft.
4. Remove rear sideplate (2-047-0) by using jackscrews provided for that purpose. Remove gland side liner (2-174-0).
5. Remove both bearing cylinder straps (5-127-0).
6. Drain oil from bearing cylinder (5-084-0) by removing side pipe plug.
7. Loosen adjusting screws. Then rotate bearing cylinder assembly so that the cylinder lugs do not foul pedestal (5-083-0) when removing the bearing cylinder assembly.
8. Place the bearing cylinder assembly on work bench and, if possible, hold it in a fixed position.
9. Remove packing (6-924-0) and water seal bushing (6-008-0) from the casing. Note the order in which parts are removed in this arrangement. See page 2 for stuffing box arrangement A or B.
10. The stuffing box (6-073-0) normally would not be removed. If necessary, it can be removed by unscrewing retaining nuts and removing the tapered dowel pins. Remove O-ring (6-914-0).
11. Remove shaft sleeve nut (5-015-0). Remove water slinger (5-024-3). Remove inboard bearing cover (5-018-3) and accompanying gasket (5-409-3). Remove cover carefully so as not to damage bearing seal. Now bearing cover seal (5-177-3) may be inspected and removed if necessary.
12. With key removed from the shaft, the outboard bearing cover (5-018-4) will slide off the shaft after removal of bolts. Clean shaft before removing bearing cover. Remove accompanying O-ring (5-914-4). Now bearing cover seal (5-177-4) may be inspected and removed if necessary.
13. Remove shaft (5-007-0) and bearing assemblies from the bearing cylinder by supporting shaft and using bearing housing (5-025-4) tap holes, jack the rotating element out of the bearing cylinder. Remove bearing housing O-ring (5-914-0).
14. Remove inboard roller bearing (5-038-3) by using a suitable bearing puller. Remove oil slinger (5-485-4). Now push or slide bearing housing (5-025-4) off toward the impeller end of shaft. Remove springs in bearing housing. Remove bearing locknut (5-516-4) and lockwasher (5-517-4). Using SKF KM—31 withdrawal nut, remove outboard roller bearing (5-038-4) and bearing spacer (5-078-4). Remove thrust bearing (5-038-0) by using a suitable bearing puller.

ASSEMBLY PROCEDURE

IMPORTANT - It is essential that all parts be thoroughly cleaned before reassembly. When handling rotating element and bearings, maintain a clean and dust-free environment. Do not unwrap new bearings prior to their installation. New bearings are coated with a rust preventative having good lubricating qualities. This coating should not be removed unless the bearings have become dirty while in storage.

1. Mount thrust bearing spacer ring on shaft (5-007-0) and contact shoulder. Mount thrust bearing (5-038-0) on shaft (shrink fit) by first heating it in hot oil at approximately 150° F (66° C) for sufficient expansion. In mounting, inner race of bearing must contact spacer ring. Dry cool bearing to room temperature.
2. Mount bearing spacer with largest diameter adjacent to thrust bearing. Withdrawal sleeve (5-078-4) together with outboard roller bearing (5-038-4) are placed on shaft. Inner race of bearing must contact spacer. Mount lockwasher (5-517-4) and locknut (5-516-4). Using locknut, drive withdrawal sleeve in outboard roller bearing so that thrust bearing total clearance between rollers and outer race is set at .005-.007". **Note** withdrawal sleeve movement of .015" reduces radial clearance of thrust bearing by .001" approximately. Lock in proper clearance position.
3. Place the four springs in bearing housing (5-025-4) and slide housing on shaft and over bearings. Assemble bearing seal (5-177-4) and O-ring (5-914-4) in cover (5-018-4) and mount to bearing housing using the three tapped holes in housing. After tightening screws an axial clearance of .005-.030" between outer race of thrust bearing and bearing housing should exist. Check this clearance by using the cored hole for oil return at bottom of housing. Mount oil slinger (5-485-4).
4. Mount inboard roller bearing (5-038-3) on shaft (shrink fit) by first heating it in hot oil at approximately 150° F (66° C) for sufficient expansion. In mounting, inner race of bearing must contact shaft shoulder. Dry cool bearing to room temperature.
5. Mount O-ring (5-914-0) on housing. Assemble shaft and bearings into bearing cylinder (5-084-0). This can be done either horizontally or vertically. In each case, inboard bearing (5-038-3) outer race must be parallel and square to shaft when assembling. Shaft must be held securely when guiding into cylinder while taking care not to damage shaft surfaces.
6. Bolt bearing housing and cover assembly (5-025-4) and (5-018-4) to bearing cylinder (5-084-0). Mount bearing seal (5-177-3) in cover (5-018-3) and using gasket (5-409-3) bolt bearing cover to bearing cylinder. Mount water slinger (5-024-3). Install shaft sleeve nut (5-015-0).
7. If required, install stuffing box (6-073-0) with O-ring (6-914-0) at this time. Replace taper dowels. Install water seal bushing (6-008-0).
8. Place bearing cylinder (5-084-0) on pedestal (5-083-0) and bolt straps (5-127-0) into place. Leave bolts slightly loose for later adjustment, step 12.
9. Install gland side liner (2-174-0), and then rear sideplate (2-047-0). Mount shaft sleeve (1-009-0). Replace packing (6-924-0) and gland (6-014-0).
10. Screw on impeller (4-002-0). After seating on shaft shoulder, tighten shaft sleeve nut (5-015-0).
11. Replace suction side liner (2-074-5) and then suction sideplate (2-046-5). Bolt two half casings together. Check sideplate stud nuts for tightness.
12. *See impeller clearance adjustment.* After clearance is established secure all bolts on bearing cylinder straps. Secure adjusting screws.
13. Reconnect suction and discharge piping.
14. Fill bearing cylinder with oil using oil cap (5-530-0) to proper level (see sight glass). Cylinder must be horizontal and level so that both sight glass oil readings are identical. Pack both bearing cover seals with high temperature grease through grease fittings (5-905-0). See LUBRICATION, page 2.

IMPELLER CLEARANCE ADJUSTMENT

1. Loosen the bolts clamping down the bearing cylinder or frame liner straps.
2. By means of the adjusting screw, move the bearing cylinder forward until the impeller touches the suction side liner. This is tested by rotating the shaft by hand.
3. The bearing cylinder or frame liner should then be brought back .040" so that the impeller will not rub on suction liner.
4. Check the rotating element by hand for freedom of rotation.
5. Retighten bearing cylinder straps. By making this adjustment periodically (depending on the rate of wear) original pump efficiency can be maintained.

SECTIONAL ASSEMBLY 20x18x40 SRL-C

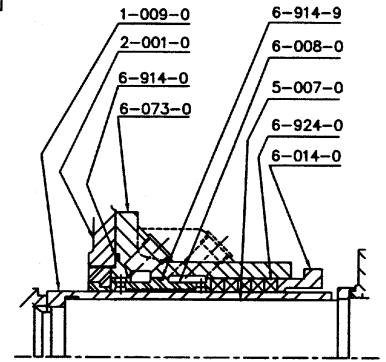
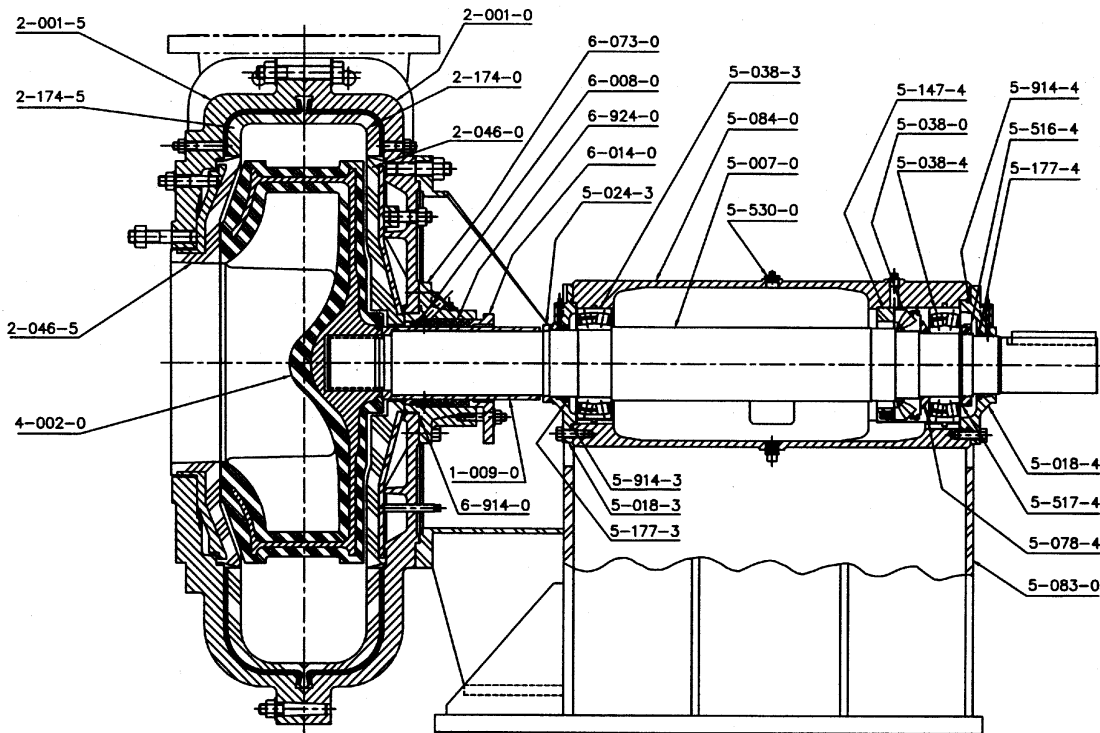

HIGH PRESSURE ARRANGEMENT - 400 PSI

<i>Cat No.</i>	<i>Description</i>	<i>Cat No.</i>	<i>Description</i>	<i>Cat No.</i>	<i>Description</i>
1-009-0	Shaft Sleeve	5-018-4	Bearing Cover (Outb.)	5-516-4	Bearing Locknut
1-248	Suct. Casing Support	5-024-3	Water Slinger	5-517-4	Bearing Lockwasher
2-001-0	Gland Half Casing	5-038-0	Thrust Bearing	5-530-0	Oil Filler Cap With Vent
2-001-5	Suction Half Casing	5-038-3	Roller Bearing (Inb.)	5-914-3	O-ring Bearing Cover
2-047-0	Rear Sideplate	5-038-4	Roller Bearing (Outb.)	5-914-4	O-ring Bearing Cover
2-046-5	Suction Sideplate	5-078-4	Bearing Spacer	6-008-0	Water Seal Bushing
2-174-0	Gland Side Liner	5-083-0	Pedestal	6-014-0	Gland
2-174-5	Suction Side Liner	5-084-0	Bearing Cylinder	6-073-0	Stuffing Box
4-002-0	Impeller	5-147-4	Spacer	6-914-0	O-ring Stuffing Box
5-007-0	Shaft	5-177-3	Bearing Seal (Inb.)	6-914-9	O-ring Labyrinth Bush
5-018-3	Bearing Cover (Inb.)	5-177-4	Bearing Seal (Outb.)	6-924-0	Packing

20x18x40 SRL-C

DISMANTLING PROCEDURE

1. Open casing by removing a section of the suction pipe, breaking discharge pipe connection, supporting discharge pipe and loosening and removing the bolts holding the casing halves together while making sure suction side casing is properly supported from dropping. Suction half casing (2-001-5) can then be removed. Remove suction sideplate (2-046-5) by using jackscrews provided for that purpose. The suction side liner (2-174-5) may be removed by using jackscrews provided for that purpose.
2. Impeller (4-002-0) is mounted with a right hand thread. Rotation is clockwise when viewed from the pump drive end. To remove the impeller, hold the shaft to keep it from rotating and apply an adequate shock load on impeller in a counterclockwise direction (viewed from impeller end) to unscrew it.
3. Remove gland (6-014-0). Remove Shaft sleeve (1-009-0) by sliding it off the shaft.
4. Remove rear sideplate (2-047-0) by using jackscrews provided for that purpose. Remove gland side liner (2-174-0) by using jackscrews provided for that purpose.
5. Remove bolts holding down bearing cylinder (5-084-0).
6. Drain oil from bearing cylinder (5-084-0) by removing the bottom pipe plug.
7. Loosen adjusting screws. Remove bearing cylinder assembly out from casing and off the pedestal (5-083-0).
8. Place the bearing cylinder assembly on work bench and, if possible, hold it in a fixed position.
9. Remove packing (6-924-0) and water seal bushing (6-008-0) from the casing. Note the order in which parts are removed in this arrangement. See page 2 for standard stuffing box arrangement or see sectional arrangement for heavy duty stuffing box..
10. The stuffing box (6-073-0) normally would not be removed. If necessary it can be removed by unscrewing retaining nuts and removing the tapered dowel pins. Remove O-ring (6-914-0).
11. Remove water slinger (5-024-3). Remove inboard bearing cover (5-018-3) and accompanying O-ring (5-914-3). Remove cover carefully so as not to damage bearing seal (5-177-3). Now bearing seal may be inspected and removed if necessary.
12. With key removed from the shaft, the outboard bearing cover (5-018-4) will slide off the shaft after removal of bolts. Clean shaft before removing bearing cover. Remove accompanying O-ring (5-914-4). Now bearing cover seal (5-177-4) may be inspected and removed if necessary.
13. To remove shaft and bearings, hold bearing cylinder in a vertical position using cylinder body pads. Place shoulder type eyebolt in end of shaft (5-007-0) and pull out from cylinder.
14. Remove inboard roller bearing (5-038-3) by using a suitable bearing puller. Remove spring retainer (5-147-4) and springs. Remove bearing locknut (5-516-4) and lockwasher (5-517-4). Remove outboard roller bearing (5-038-4) by using a suitable bearing puller. Remove bearing spacer (5-078-4). Remove thrust bearing (5-038-0) by using a suitable bearing puller. Slide thrust bearing spacer ring off the shaft.

ASSEMBLY PROCEDURE

IMPORTANT - It is essential that all parts be thoroughly cleaned before reassembly. When handling rotating element and bearings, maintain a clean and dust-free environment. Do not unwrap new bearings prior to their installation. New bearings are coated with a rust preventative having good lubricating qualities. This coating should not be removed unless the bearings have become dirty while in storage.

1. Mount inboard roller bearing (5-038-3) on shaft (shrink fit) by first heating them in hot oil at approximately 150° F (66° C) for sufficient expansion. In mounting, inner race of bearing must contact shaft shoulder. Dry cool bearing to room temperature.
2. Place spring retainer (5-147-4) on shaft and also outer race of thrust bearing. Mount thrust bearing spacer ring on shaft (5-007-0) to contact shoulder. Mount thrust bearing (5-038-0) on shaft (shrink fit) by first heating it in hot oil at approximately 150° F (66° C) for sufficient expansion. In mounting, inner race of bearing must contact spacer ring. Dry cool bearing to room temperature.
3. Mount bearing spacer (5-078-4) with largest diameter adjacent to thrust bearing (5-038-0). Mount outboard roller bearing (5-038-4) on shaft using the same method as thrust bearing (5-038-0). Inner race of bearing must contact spacer. Mount lockwasher (5-517-4) and locknut (5-516-4) and tighten.
4. With bearing cylinder and shaft held securely in a vertical position begin to lower shaft in cylinder making sure that inboard bearing (5-038-3) outer race is parallel and square to shaft during assembly. At this time, place springs in spring retainer (5-147-4) and fit into cylinder bore while making sure that the outer race of thrust bearing (5-038-0) is adjacent to retainer. Put shaft and bearings into cylinder.
5. Assemble bearing seal (5-177-4) and O-ring (5-914-4) in cover (5-018-4) and mount to bearing cylinder (5-084-0). After tightening screws, an axial clearance of .004"-.015" between outer race of thrust bearing (5-038-0) and spring retainer (5-147-4) should exist. Check this clearance by using pipe tap hole on top of bearing cylinder.
6. Mount bearing seal (5-177-3) and O-ring (5-914-3) in cover (5-018-3) and bolt to bearing cylinder. Mount water slinger (5-024-3).
7. If required, install stuffing box (6-073-0) with O-ring (6-914-0) at this time. Replace taper dowels. Install water seal bushing (6-008-0).
8. Place assembled bearing cylinder on pedestal (5-083-0) and bolt into place.
9. Install gland side liner (2-174-0) and then rear sideplate (2-047-0). Mount shaft sleeve (1-009-0). Replace packing (6-924-0) and gland (6-014-0).
10. Screw on impeller (4-002-0).
11. Replace suction side liner (2-174-5) and then suction sideplate (2-046-5). Bolt two half casings together. Now check all sideplate stud nuts for tightness.
12. *See impeller clearance adjustment.* After clearance is established lock adjusting screws.
13. Fill bearing cylinder with oil using oil cap (5-530-0) to proper level (see sight glass). Cylinder must be horizontal and level so that both sight glass oil readings are identical. Pack both bearing cover seals with high temperature grease through grease fittings. See LUBRICATION page 2.
14. Reconnect suction and discharge piping.

IMPELLER CLEARANCE ADJUSTMENT

1. Loosen the bolts clamping down the bearing cylinder or frame liner straps.
2. By means of the adjusting screw, move the bearing cylinder forward until the impeller touches the suction side liner. This is tested by rotating the shaft by hand.
3. The bearing cylinder or frame liner should then be brought back .040" so that the impeller will not rub on suction liner.
4. Check the rotating element by hand for freedom of rotation.
5. Retighten bearing cylinder straps. By making this adjustment periodically (depending on the rate of wear) original pump efficiency can be maintained.

SECTIONAL ASSEMBLY and PARTS LIST 6x6x21 SRL-XT

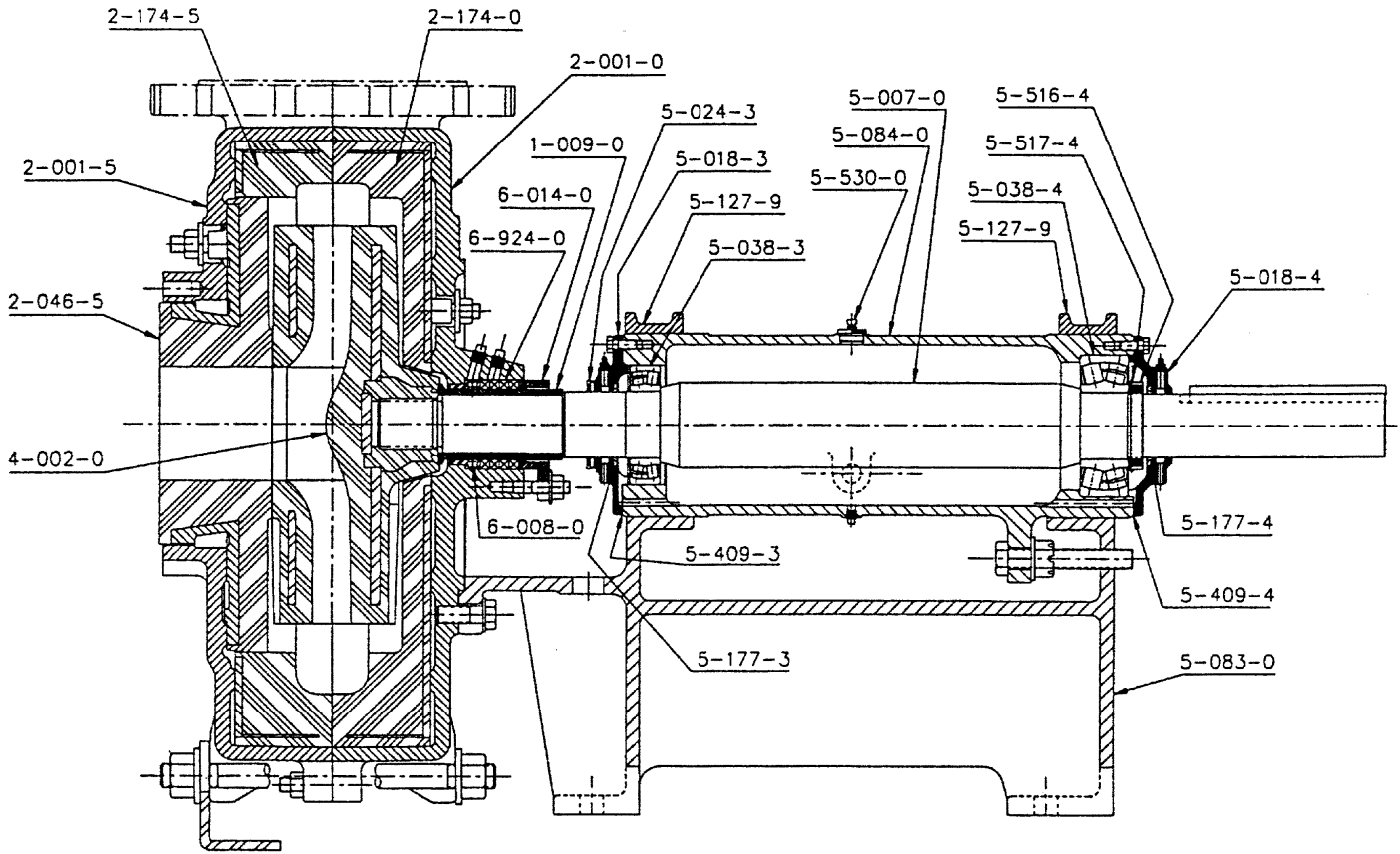

<i>Cat No.</i>	<i>Description</i>	<i>Cat No.</i>	<i>Description</i>	<i>Cat No.</i>	<i>Description</i>
1-009-0	Shaft Sleeve	5-018-4	Bearing Cover (Outb.)	5-409-3	Brg. Cover Gasket (Inb.)
2-001-0	Gland Half Casing	5-024-3	Deflector	5-409-4	Brg. Cover Gasket (Outb.)
2-001-5	Suction Half Casing	5-038-3	Roller Bearing (Inb.)	5-516-4	Bearing Locknut
2-046-5	Casing Sideplate	5-038-4	Roller Bearing (Outb.)	5-517-4	Bearing Lockwasher
2-174-0	Gland Side Liner	5-083-0	Pedestal	5-530-0	Oil Filler Cap With Vent
2-174-5	Suction Side Liner	5-084-0	Bearing Cylinder	6-008-0	Waterseal Bushing
4-002-0	Impeller	5-127-0	Bearing Cylinder Strap	6-014-0	Gland
5-007-0	Shaft	5-177-3	Bearing Seal (Inb.)	6-924-0	Packing
5-018-3	Bearing Cover (Inb.)	5-177-4	Bearing Seal (Outb.)		

6x6x21 SRL-XT

DISMANTLING PROCEDURE

1. Open casing by removing a section of the suction pipe, breaking discharge pipe connection, supporting discharge pipe and loosening and removing the bolts holding the casing halves together while making sure suction side casing is properly supported from dropping. Suction half casing (2-001-5) can then be removed. Remove casing sideplate (2-046-5). The suction side liner (rubber-lined 2-174-5) may be removed by using jackscrews provided for that purpose.
2. Impeller (4-002-0) is mounted with a right hand thread. Rotation is clockwise when viewed from the pump drive end. To remove the impeller, hold the shaft to keep it from rotating and pound on a hardwood block held against the impeller vane at the periphery in the counterclockwise direction when viewed from the impeller end.
3. Remove gland side liner (rubber-lined 2-174-0) from the casing.
4. Remove gland (6-014-0). Remove shaft sleeve (1-009-0) by prying it loose at stuffing box and sliding it off the shaft.
5. Remove both bearing cylinder straps (5-127-9).
6. Drain oil from bearing cylinder (5-084-0) by removing the bottom pipe plug.
7. Remove adjusting screw mechanism which includes cotter pin, castle nut and washer. Then rotate bearing cylinder assembly so that the cylinder lug does not foul pedestal (5-083-0) when removing the bearing cylinder assembly.
8. Place the bearing cylinder assembly on work bench and, if possible, hold the cylinder in a fixed position.
9. Remove packing (6-924-0) and bushing (6-008-0) from the casing. Note the order in which parts are removed in this arrangement. See page 2 for stuffing box arrangement A or B.
10. Remove deflector (5-024-3) from the shaft. Remove inboard bearing cover (5-018-3) and accompanying gasket (5-409-3). Now bearing seal (5-177-3) may be inspected and removed if necessary.
11. With sheave and key removed from the shaft, the outboard bearing cover (5-018-4) will slide off the shaft after removal of bolts. Clean shaft before removing bearing cover. Remove accompanying gasket (5-409-4). Now bearing seal (5-177-4) may be inspected and removed if necessary.
12. Remove shaft (5-007-0) and bearings (5-038-3 and 5-038-4) from the bearing cylinder using a drift pin and hammer or a hydraulic press if available.
13. Remove bearing locknut (5-516-4) and lockwasher (5-517-4). Remove bearings by using a hydraulic press or suitable bearing puller.

ASSEMBLY PROCEDURE

IMPORTANT - It is essential that all parts be thoroughly cleaned before reassembly. When handling rotating elements and bearings, maintain a clean and dust-free environment. Do not unwrap new bearings prior to their installation. New bearings are coated with a rust preventative having good lubricating qualities. This coating should not be removed unless the bearings have become dirty while in storage.

1. Mount bearings (5-038-3 and 5-038-4) on shaft (shrink fit) by first heating them in hot oil at approximately 150° F (66° C) for sufficient expansion. In mounting, inner race of bearings must contact shaft shoulder. Dry cool bearings to room temperature.
 2. Assemble lockwasher (5-517-0) and locknut (5-516-4).
 3. Assemble shaft and bearings into cylinder or frame liner (5-084-0). This can be done either horizontally or vertically. In each case inboard bearing (5-038-3) outer race must be parallel and square to shaft when assembling. Shaft must be held securely when guiding into cylinder while taking care not to damage shaft surfaces.
 4. Mount seals (5-177-4 and 5-177-3) in bearing covers (5-018-4 and 5-018-3). Replace gaskets (5-409-4 and 5-409-3). Install deflector (5-040-3).
 5. Install waterseal bushing (6-008-0).
 6. Place bearing cylinder or frame liner on pedestal (5-083-0) and bolt bearing cylinder straps (5-127-9) into place. Leave bolts slightly loose for later adjustment, step 11.
- Reassemble adjusting screw mechanism.
7. Mount shaft sleeve (1-009-0). Replace packing (6-924-0) and gland (6-014-0). Check if waterseal bushing (6-008-0) is concentric with sleeve.
 8. Replace gland side liner (2-174-0). Do not use excessive force on liner stud nuts.
 9. Screw on impeller (4-002-0).
 10. Replace suction side liner (2-714-5). Replace casing (2-046-5). Do not use excessive force on casing sideplate stud nuts. Bolt two half casings together. Check casing sideplate stud nuts for tightness.
 11. *See impeller clearance adjustment.* After clearance is established, secure all bolts on bearing cylinder straps.
 12. Reconnect suction and discharge piping.
 13. Fill cylinder or frame liner with oil to proper level and pack both bearing cover seals with high temperature grease through connections provided. See LUBRICATION page 2.

IMPELLER CLEARANCE ADJUSTMENT

1. Loosen the bolts clamping down the bearing cylinder or frame liner straps.
2. By means of the adjusting screw, move the bearing cylinder forward until the impeller touches the suction sideplate. This is tested by rotating the shaft by hand.
3. The bearing cylinder or frame liner should then be brought back 1/16" so that the impeller will not rub on casing sideplate.
4. Check the rotating element by hand for freedom of rotation.
5. Retighten bearing cylinder straps. By making this adjustment periodically (depending on the rate of wear) original pump efficiency can be maintained.

SECTIONAL ASSEMBLY and PARTS LIST 8x8x25 SRL-XT

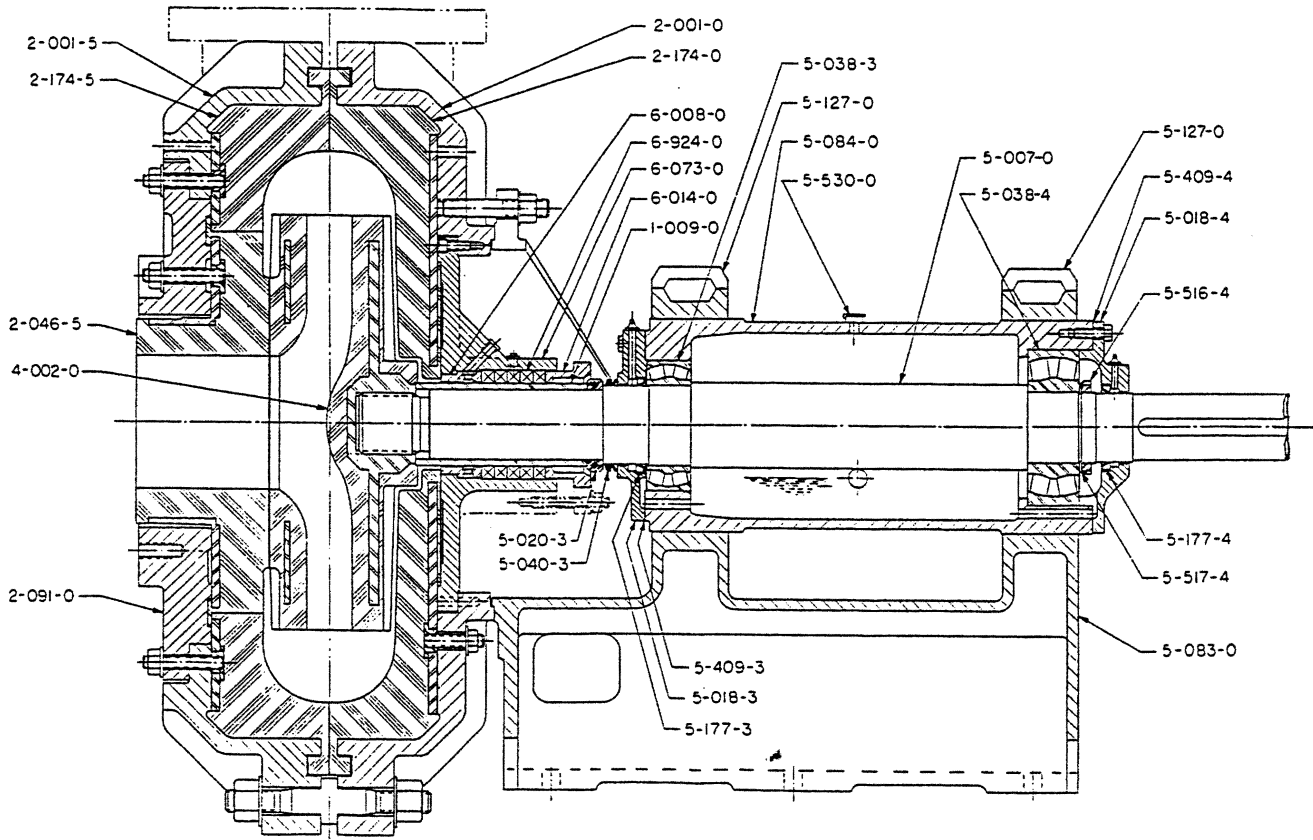

Cat No.	Description	Cat No.	Description	Cat No.	Description
1-009-0	Shaft Sleeve	5-018-4	Bearing Cover (Outb.)	5-409-3	Brg. Cover Gasket (Inb.)
2-001-0	Gland Half Casing	5-020-3	Release Collar	5-409-4	Brg. Cover Gasket (Outb.)t
2-001-5	Suction Half Casing	5-038-3	Roller Bearing (Inb.)	5-516-4	Bearing Locknut
2-046-5	Suction Sideplate	5-038-4	Roller Bearing (Outb.)	5-517-4	Bearing Lockwasher
2-091-0	Suction Cover	5-040-3	Deflector	5-530-0	Oil Filler Cap With Vent
2-174-0	Gland Side Liner	5-083-0	Pedestal	6-008-0	Water Seal Bushing
2-174-5	Suction Side Liner	5-084-0	Bearing Cylinder	6-014-0	Gland
4-002-0	Impeller	5-127-0	Bearing Cylinder Strap	6-073-0	Stuffing Box
5-007-0	Shaft	5-177-3	Bearing Seal (Inb.)	6-924-0	Packing
5-018-3	Bearing Cover (Inb.)	5-177-4	Bearing Seal (Outb.)		

8x8x25 SRL-XT

DISMANTLING PROCEDURE

1. Remove section of suction pipe adjacent to suction casing (2-001-5). Casing is provided with removable cover (2-091-0) with suction (2-046-5) attached. Cover is held to casing by (12) studs and retaining nuts of which (4) hold suction side liner (2-174-5) in place. Remove cover and attached suction sideplate by means of jackscrews provided. If necessary, remove suction sideplate from cover attached by (4) retaining studs and nuts. Break discharge connection, support discharge pipe, loosen and remove bolts holding casing halves. Make sure suction casing is supported from dropping. After suction casing is removed, suction side liner (2-174-5) can be removed with jackscrews provided.
2. Impeller (4-002-0) is mounted with a right hand thread. Rotation is clockwise viewed from the pump drive end. To remove the impeller, first remove the shaft sleeve nut (5-020-3). This is done by removing the two (2) Socket Head. Then using one as jackscrew in tapped hole at crown of nut, force joints apart sufficiently to lever one nut half clear from shaft shoulder. Other half may then be removed by hitting nut with wooden mallet or of similar soft material to prevent damage to nut half. With nut off, impeller can be easily removed from shaft by the application of shock load counterclockwise (viewed from impeller end) while holding shaft from rotating.
3. Remove gland (6-014-0). Remove shaft sleeve (1-009-0) by sliding it off the shaft.
4. Remove gland side liner (2-174-0) by means of jackscrews provided.
5. Remove both bearing cylinder straps (5-127-0).
6. Drain oil from bearing cylinder (5-084-0) by removing side pipe plug.
7. Loosen adjusting screws. Then rotate bearing cylinder assembly so that the cylinder lugs do not foul pedestal (5-083-0) when removing the bearing cylinder assembly.
8. Place the bearing cylinder assembly on work bench and, if possible, hold it in a fixed position.
9. Remove packing (6-924-0) and waterseal bushing (6-008-0) from the stuffing box. Note the order in which parts are removed in this arrangement. See page 2 for stuffing box arrangement A or B.
10. Stuffing box (6-073-0) normally would not be removed unless waterseal bushing (6-008-0) needs replacement. If required, unscrew (4) retaining socket capscrews. Then using two (2) jackscrews in tapped holes remove stuffing box from casing.
11. Remove deflector (5-040-3). Remove inboard bearing cover (5-018-3) and accompanying gasket (5-409-3). Remove cover carefully so as not to damage bearing seal. Now bearing seal (5-177-3) may be inspected and removed, if necessary.
12. With key removed from shaft, the outboard bearing cover (5-018-4) will slide off the shaft after removal of bolts. Clean shaft before removing bearing cover. Remove accompanying gasket (5-409-4). Now bearing cover seal (5-177-4) may be inspected and removed, if necessary.
13. Remove shaft (5-007-0) and bearings (5-038-3) and (5-038-4) from the bearing cylinder by supporting shaft and pushing or pulling it out from the cylinder. Take care not to damage shaft surfaces.
14. Remove inboard roller bearing (5-038-3) by using a suitable bearing puller. Remove locknut (5-516-4) and lockwasher (5-517-4). Remove outboard roller bearing (5-038-4) by using a suitable bearing puller.

ASSEMBLY PROCEDURE

IMPORTANT- It is essential that all parts be thoroughly cleaned before reassembly. When handling rotating elements and bearings, maintain a clean and dust-free environment. Do not unwrap new bearings prior to their installation. New bearings are coated with a rust preventative having good lubricating qualities. This coating should not be removed unless the bearings have become dirty while in storage.

1. Mount bearings (5-038-3 and 5-038-4) on shaft (shrink fit) by first heating them in hot oil at approximately 150° F (66° C) for sufficient expansion. In mounting, inner race of bearings must contact shaft shoulder. Dry cool bearings to room temperature.
2. Assemble lockwasher (5-517-4) and locknut (5-516-4).
3. Assemble shaft and bearings into cylinder or frame liner (5-084-0). This can be done either horizontally or vertically. In each case inboard bearing (5-038-3) outer race must be parallel and square to shaft when assembling. Shaft must be held securely when guiding into cylinder while taking care not to damage shaft surfaces.
4. Mount seals (5-177-4 and 5-177-3) in bearing covers (5-018-4 and 5-018-3). Replace gaskets (5-409-4 and 5-409-3). Bolt covers to bearing cylinder (5-084-0). Install deflector (5-040-3).
5. If removed from casing, re-install stuffing box (6-073-0) at this time. Install water seal bushing (6-008-0) and mount stuffing box in gland half casing (2-001-0), using two straight dowels to locate the stuffing box.
6. Place bearing cylinder (5-084-0) on pedestal (5-083-0) and bolt straps (5-127-0) into place. Leave bolts slightly loose for later adjustment, step 10.
7. Install gland side liner (2-174-0). Re-assemble sleeve nut (5-020-3) and mount against shaft shoulder. Mount sleeve (1-009-0). Replace packing (6-924-0) and gland (6-014-0).
8. Screw on impeller (4-002-0).
9. Replace suction side liner (2-714-5) and replace retaining studs finger tight. Replace suction cover (2-091-0) complete with suction sideplate (2-046-5). Secure cover to casing and tighten side liner and sideplate retaining stud nuts. Bolt casing halves together and then recheck above-mentioned nuts for tightness.
10. *See impeller clearance adjustment.* After clearance is established secure all bolts on bearing cylinder straps. Secure adjusting screws.
11. Reconnect suction and discharge piping. 12. Fill bearing cylinder with oil using oil cap (5-030-0) to proper level (see sight glass). Cylinder must be horizontal and level so that both sight glass oil readings are identical. Pack both bearing cover seals with high temperature grease through grease fittings on covers. See LUBRICATION page 2.

IMPELLER CLEARANCE ADJUSTMENT

1. Loosen the bolts clamping down the bearing cylinder or frame liner straps.
2. By means of the adjusting screw, move the bearing cylinder forward until the impeller touches the suction sideplate. This is tested by rotating the shaft by hand.
3. The bearing cylinder or frame liner should then be brought back 1/16" so that the impeller will not rub on suction sideplate.
4. Check the rotating element by hand for freedom of rotation.
5. Retighten bearing cylinder straps. By making this adjustment periodically (depending on the rate of wear) original pump efficiency can be maintained.

SECTIONAL ASSEMBLY and PARTS LIST 10x10x28 SRL-XT

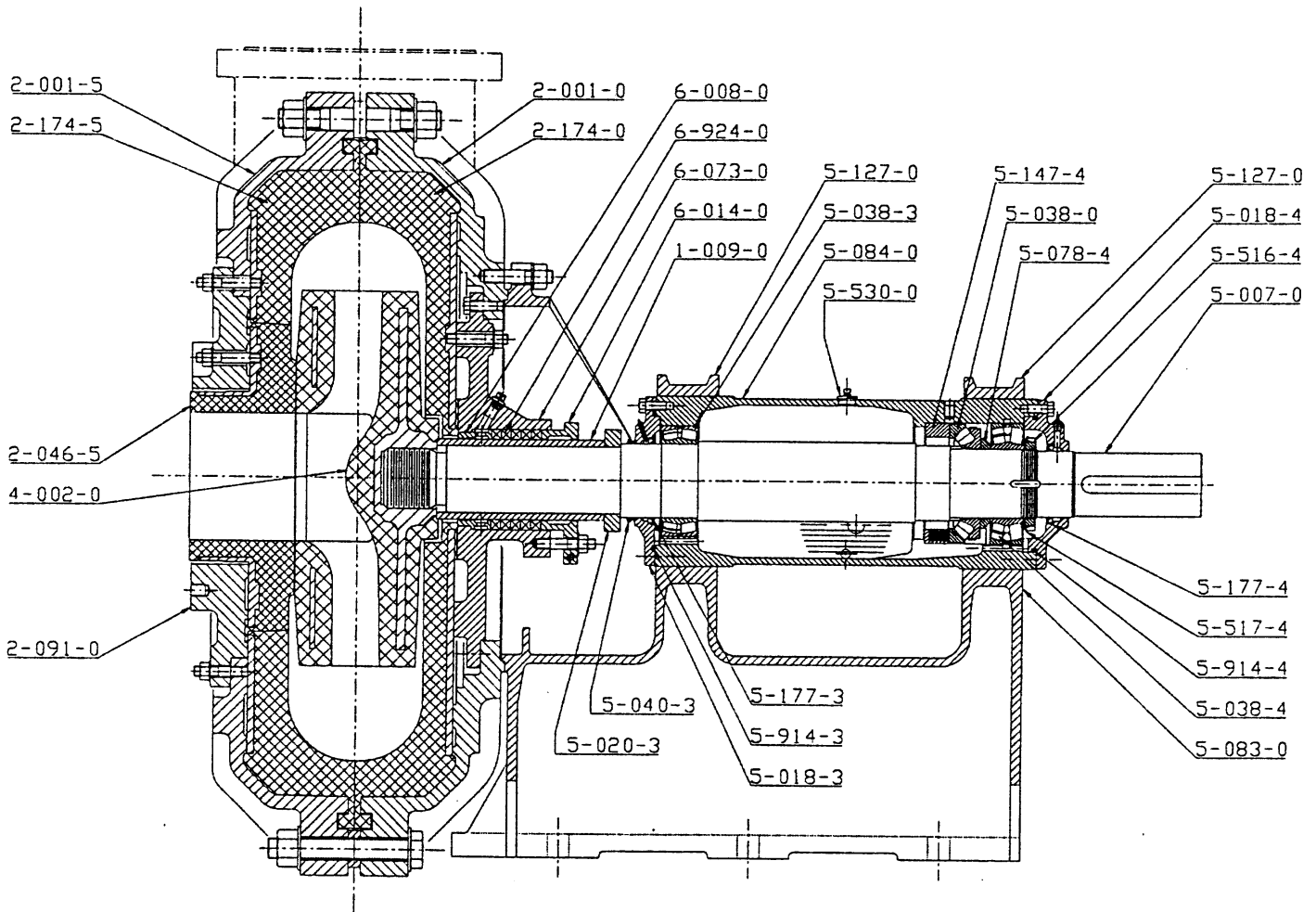

Cat No.	Description	Cat No.	Description	Cat No.	Description
1-009-0	Shaft Sleeve	5-038-0	Thrust Bearing	5-409-4	Brg. Cov. Gasket (Outb.)
2-001-0	Gland Half Casing	5-038-3	Roller Bearing (Inb.)	5-516-4	Bearing Locknut
2-001-5	Suction Half Casing	5-038-4	Roller Bearing (Outb.)	5-517-4	Bearing Lockwasher
2-046-5	Suction Sideplate	5-040-3	Deflector	5-530-0	Oil Filler Cap With Vent
2-091-0	Suction Cover	5-078-4	Bearing Spacer	5-914-3	O-ring Brg. Cover (Inb.)
2-174-0	Gland Side Liner	5-083-0	Pedestal	5-914-4	O-ring Brg. Cover (Outb.)
2-174-5	Suction Side Liner	5-084-0	Bearing Cylinder	6-008-0	Water Seal Bushing
4-002-0	Impeller	5-127-0	Bearing Cylinder Strap	6-014-0	Gland
5-007-0	Shaft	5-147-4	Spacer	6-073-0	Stuffing Box
5-018-3	Bearing Cover (Inb.)	5-177-3	Bearing Seal Inboard	6-924-0	Packing
5-018-4	Bearing Cover (Outb.)	5-177-4	Bearing Seal Outboard		
5-020-3	Release Collar	5-409-3	Brg. Cov. Gasket (Inb.)		

10x10x28 SRL-XT

DISMANTLING PROCEDURE

1. Remove section of suction pipe adjacent to suction casing (2-001-5). Casing is provided with removable cover (2-091-0) with suction sideplate (2-046-5) attached. Cover is held to casing by (12) studs and retaining nuts of which (4) hold suction side liner (2-174-5) in place. Remove cover and attached suction sideplate by means of jackscrews provided. If necessary, remove suction sideplate from cover attached by (4) retaining studs and nuts.

Break discharge connection, support discharge pipe, loosen and remove bolts holding casing halves. Make sure suction casing is supported from dropping. After suction casing is removed, suction side liner (2-174-5) can be removed with jackscrews provided.

2. Impeller (4-002-0) is mounted with a right hand thread. Rotation is clockwise viewed from the pump drive end. To remove the impeller, first remove the shaft sleeve nut (5-020-3). This is done by removing the two (2) Socket Head. Then using one as jackscrew in tapped hole at crown of nut, force joints apart sufficiently to lever one nut half clear from shaft shoulder. Other half may then be removed by hitting nut with wooden mallet or of similar soft material to prevent damage to nut half. With nut off, impeller can be easily removed from shaft by the application of shock load counterclockwise (viewed from impeller end) while holding shaft from rotating.

3. Remove gland (6-014-0). Remove shaft sleeve (1-009-0) by sliding it off the shaft.

4. Remove gland side liner (2-174-0) by means of jackscrews provided.

5. Remove both bearing cylinder straps (5-127-0).

6. Drain oil from bearing cylinder (5-084-0) by removing side pipe plug.

7. Loosen adjusting screws. Then rotate bearing cylinder assembly so that the cylinder lugs do not foul pedestal (5-083-0) when removing the bearing cylinder assembly.

8. Place the bearing cylinder assembly on work bench and, if possible, hold it in a fixed position.

9. Remove packing (6-924-0) and water seal bushing (6-008-0) from the stuffing box. Note the order in which parts are removed in this arrangement. See page 2 for stuffing box arrangement A or B.

10. Stuffing box (6-073-0) normally would not be removed unless bushing (6-008-0) needs replacement. If required, unscrew (4) retaining socketcapscrews. Then using two (2) jackscrews in tapped holes remove stuffing box from casing.

11. Remove deflector (5-040-3). Remove inboard bearing cover (5-018-3) and accompanying O-ring (5-914-3). Remove cover carefully so as not to damage bearing seal. Now bearing seal (5-177-3) may be inspected and removed, if necessary.

12. With key removed from shaft, the outboard bearing cover (5-018-4) will slide off the shaft after removal of bolts. Clean shaft before removing bearing cover. Remove accompanying O-ring (5-194-4). Now bearing cover seal (5-177-4) may be inspected and removed, if necessary.

13. Remove shaft (5-007-0) and bearing assemblies from the bearing cylinder by supporting shaft and pushing or pulling it out from the cylinder. Take care not to damage shaft surfaces.

14. Remove inboard roller bearing (5-038-3) by using a suitable bearing puller. Remove locknut (5-516-4) and lockwasher (5-517-4). Remove outboard roller bearing (5-038-4) by using a suitable bearing puller. Remove bearing spacer (5-078-4). Remove thrust bearing (5-038-0) by using a suitable bearing puller. Now remove spring retainer (5-147-4) and accompanying springs.

ASSEMBLY PROCEDURE

IMPORTANT - It is essential that all parts be thoroughly cleaned before reassembly. When handling rotating elements and bearings, maintain a clean and dust-free environment. Do not unwrap new bearings prior to their installation. New bearings are coated with a rust preventative having good lubricating qualities. This coating should not be removed unless the bearings have become dirty while in storage.

1. Mount inboard roller bearing (5-038-3) on shaft (shrink fit) by first heating it in hot oil at approximately 150° F (66° C) for sufficient expansion. In mounting, inner race of bearing must contact shaft shoulder. Dry cool bearing to room temperature.

2. Place spring retainer (5-147-4) on shaft and also outer race of thrust bearing. Mount thrust bearing spacer ring on shaft (5-007-0) to contact shoulder. Mount thrust bearing (5-038-0) on shaft (shrink fit) by first heating it in hot oil at approximately 150° F (66° C) for sufficient expansion. In mounting, inner race of bearing must contact spacer ring. Dry cool bearing to room temperature.

3. Mount bearing spacer (5-078-4) with largest diameter adjacent to thrust bearing (5-038-0). Mount outboard roller bearing (5-038-4) on shaft using the same method as thrust bearing (5-038-0). Inner race of bearing must contact spacer.

4. Mount (5-517-4) and locknut (5-516-4). During assembly of shaft and bearings into cylinder (5-084-0) place springs into spring retainer (5-147-4) and align retainer with outer race of thrust bearing (5-038-0) so that both will enter bearing cylinder bore during assembly sequence. Also ensure that inboard bearing (5-038-3) outer race is parallel and square to shaft at assembly. Put shaft and bearings into cylinder.

5. Assemble bearing seal (5-177-4) and O-ring (5-914-4) in cover (5-018-4) and mount to bearing cylinder (5-084-0). After tightening screws, an axial clearance of .004" - .015" between outer race of thrust bearing (5-038-0) and spring retainer (5-147-4) should exist. Check this clearance by using hole on top of bearing cylinder.

6. Mount bearing seal (5-177-3) and O-ring (5-914-3) in cover (5-018-3) and bolt to bearing cylinder. Mount deflector (5-040-3).

7. If removed from casing, re-install stuffing box (6-073-0) at this time. Install water seal bushing (6-008-0) and mount stuffing box in gland half casing (2-001-0), using two straight dowels to locate the stuffing box.

8. Place bearing cylinder (5-084-0) on pedestal (5-083-0) and bolt straps (5-127-0) into place. Leave bolts slightly loose for later adjustment, step 12.

9. Install gland side liner (2-174-0). Re-assemble sleeve nut (5-020-3) and mount against shaft shoulder. Mount sleeve (1-009-0). Replace packing (6-924-0) and gland (6-014-0).

10. Screw on impeller (4-002-0).

11. Replace suction side liner (2-714-5) and replace retaining studs finger tight. Replace suction cover (2-091-0) complete with suction sideplate (2-046-5). Secure cover to casing and tighten side liner and sideplate retaining stud nuts. Bolt casing halves together and then recheck above-mentioned nuts for tightness.

12. *See impeller clearance adjustment.* After clearance is established secure all bolts on bearing cylinder straps. Secure adjusting screws.

13. Reconnect suction and discharge piping.

14. Fill bearing cylinder with oil using oil cap (5-530-0) to proper level (see sight glass). Cylinder must be horizontal and level so that both sight glass oil readings are identical. Pack both bearing cover seals with high temperature grease through grease fittings on covers. See LUBRICATION page 2.

IMPELLER CLEARANCE ADJUSTMENT

1. Loosen the bolts clamping down the bearing cylinder or frame liner straps.
2. By means of the adjusting screw, move the bearing cylinder forward until the impeller touches the suction sideplate. This is tested by rotating the shaft by hand.
3. The bearing cylinder or frame liner should then be brought back 1/16" so that the impeller will not rub on suction sideplate.
4. Check the rotating element by hand for freedom of rotation.
5. Retighten bearing cylinder straps. By making this adjustment periodically (depending on the rate of wear) original pump efficiency can be maintained.

SECTIONAL ASSEMBLY and PARTS LIST 14x12x36 SRL-XT

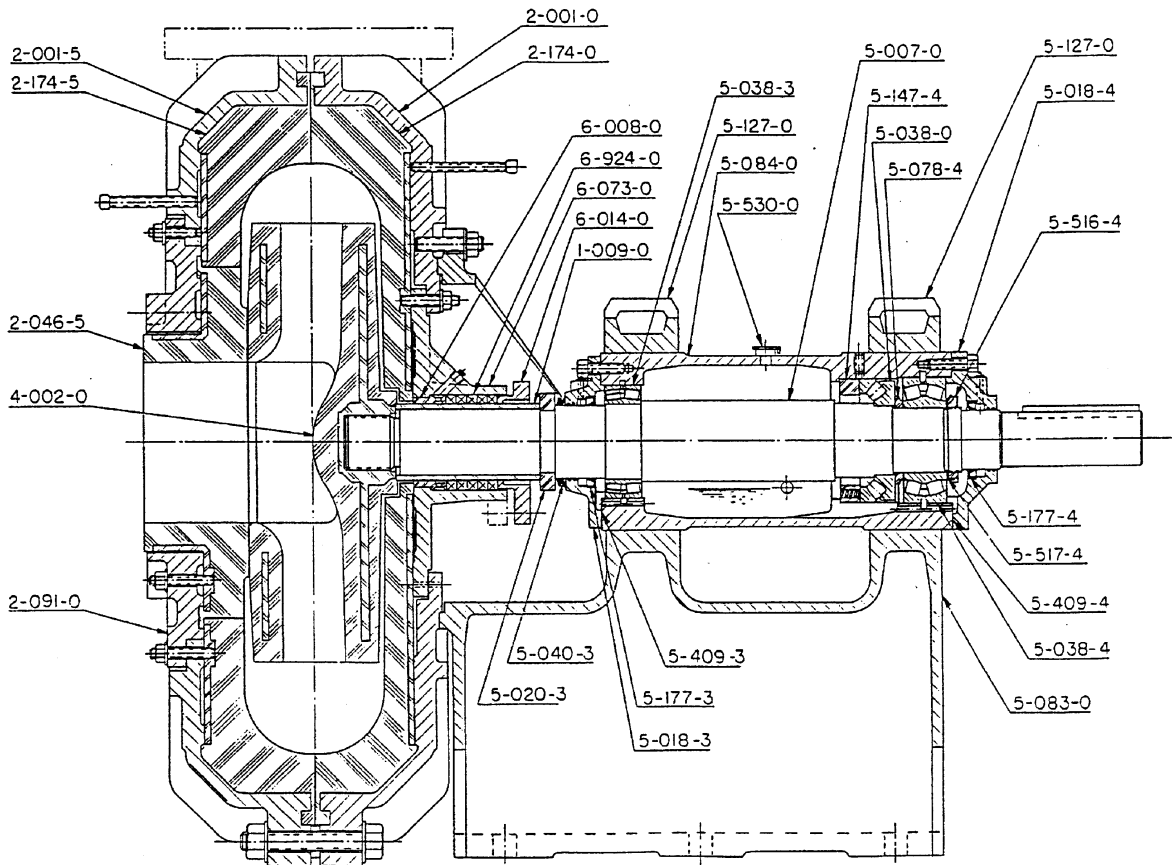

Cat No.	Description	Cat No.	Description	Cat No.	Description
1-009-0	Shaft Sleeve	5-020-3	Release Collar	5-177-4	Bearing Seal (Outb.)
2-001-0	Gland Half Casing	5-038-0	Thrust Bearing	5-516-4	Bearing Locknut
2-001-5	Suction Half Casing	5-038-3	Roller Bearing (Inb.)	5-517-4	Bearing Lockwasher
2-046-5	Suction Sideplate	5-038-4	Roller Bearing (Outb.)	5-530-0	Oil Filler Cap With Vent
2-091-0	Suction Cover	5-040-3	Deflector	5-914-3	O-ring Brg Cover (Inb.)
2-174-0	Gland Side Liner	5-078-4	Bearing Spacer	5-914-4	O-ring Brg Cover (Outb.)
2-174-5	Suction Side Liner	5-083-0	Pedestal	6-008-0	Water Seal Bushing
4-002-0	Impeller	5-084-0	Bearing Cylinder	6-014-0	Gland
5-007-0	Shaft	5-127-0	Bearing Cylinder Strap	6-073-0	Stuffing Box
5-018-3	Bearing Cover (Inb.)	5-147-4	Spring Retainer	6-924-0	Packing
5-018-4	Bearing Cover (Outb.)	5-177-3	Bearing Seal (Inb.)		

14x12x36 SRL-XT

DISMANTLING PROCEDURE

1. Remove section of suction pipe adjacent to suction casing (2-001-5). Casing is provided with removable cover (2-091-0) with suction sideplate (2-046-5) attached. Cover is held to casing by (12) studs and retaining nuts of which (4) hold suction sideliner (2-174-5) in place. Remove cover and attached suction side lockwasher (5-517-4) plate by means of jackscrews provided. If necessary, remove suction sideplate from cover attached by (4) retaining studs and nuts.

Break discharge connection, support discharge pipe, loosen and remove bolts holding casing halves. Make sure suction casing is supported from dropping. After suction casing is removed, suction side liner (2-174-5) can be removed with jackscrews provided.

2. Impeller (4-002-0) is mounted with a right hand thread. Rotation is clockwise viewed from the pump drive end. To remove the impeller, first remove the shaft sleeve nut (5-020-3). This is done by removing the two (2) Socket Head Capscrews. Then using one as jackscrew in tapped hole at crown of nut, force joints apart sufficiently to lever one nut half clear from shaft shoulder. Other half may then be removed by hitting nut with wooden mallet or of similar soft material to prevent damage to nut half. With cut off, impeller can be easily removed from shaft by the application of shock load counterclockwise (viewed from impeller end) while holding shaft from rotating.

3. Remove gland (6-014-0). Remove shaft sleeve (1-009-0) by sliding it off the shaft.

4. Remove gland side liner (2-174-0) by means of jackscrews provided.

5. Remove both bearing cylinder straps (5-127-0).

6. Drain oil from bearing cylinder (5-084-0) by removing side pipe plug.

7. Loosen adjusting screws. Then rotate bearing cylinder assembly so that the cylinder lugs do not foul pedestal (5-083-0) when removing the bearing cylinder assembly.

8. Place the bearing cylinder assembly on work bench and, if possible, hold it in a fixed position.

9. Remove packing (6-924-0) and water seal bushing (6-008-0) from the stuffing box. Note the order in which parts are removed in this arrangement. See page 2 for stuffing box arrangement A or B.

10. Stuffing box (6-073-0) normally would not be removed unless stuffing box bushing (6-008-0) needs replacement. If required, unscrew (4) retaining socket capscrews. Then using two (2) jackscrews in tapped holes remove stuffing box from casing.

11. Remove deflector (5-040-3). Remove inboard bearing cover (5-018-3) and accompanying O-ring (5-914-3). Remove cover carefully so as not to damage bearing seal. Now bearing seal (5-177-3) may be inspected and removed, if necessary.

12. With key removed from shaft, the outboard bearing cover (5-018-4) will slide off the shaft after removal of bolts. Clean shaft before removing bearing cover. Remove accompanying O-ring (5-194-4). Now bearing cover seal (5-177-4) may be inspected and removed if necessary.

13. Remove shaft (5-007-0) and bearing assemblies from the bearing cylinder by supporting shaft and pushing or pulling it out from the cylinder. Take care not to damage shaft surfaces.

14. Remove inboard roller bearing (5-038-3) by using a suitable bearing puller. Remove locknut (5-516-4) and lockwasher (5-517-4). Remove outboard roller bearing (5-038-4) by using a suitable bearing puller. Remove bearing spacer (5-078-4). Remove thrust bearing (5-038-0) by using a suitable bearing puller. Now remove spring retainer(5-147-4) and accompanying springs.

ASSEMBLY PROCEDURE

IMPORTANT - It is essential that all parts be thoroughly cleaned before reassembly. When handling rotating elements and bearings, maintain a clean and dust-free environment. Do not unwrap new bearings prior to their installation. New bearings are coated with a rust preventative having good lubricating qualities. This coating should not be removed unless the bearings have become dirty while in storage.

1. Mount inboard roller bearing (5-038-3) on shaft (shrink fit) by first heating it in hot oil at approximately 150° F (66° C) for sufficient expansion. In mounting, inner race offering must contact shaft shoulder. Dry cool bearing to room temperature.

2. Place spring retainer (5-147-4) on shaft and also outer race of thrust bearing. Mount thrust bearing spacer ring on shaft (5-007-0) to contact shoulder. Mount thrust bearing(5-038-0) on shaft (shrink fit) by first heating it in hot oil at approximately 150° F (66° C)for sufficient expansion. In mounting, inner race of bearing must contact spacer ring. Dry cool bearing to room temperature.

3. Mount bearing spacer (5-078-4) with largest diameter adjacent to thrust bearing (5-038-0). Mount outboard roller bearing (5-038-4) on shaft using the same method as thrust bearing (5-038-0). Inner race of bearing must contact spacer. Mount (5-517-4) and locknut (5-516-4) and tighten.

4. With bearing cylinder and shaft held securely in a vertical position begin to lower shaft in cylinder making sure that inboard bearing (5-308-3) outer race is parallel and square to shaft during assembly. At this time, place springs in spring retainer (5-147-4)and fit into cylinder bore while making sure that the outer race of thrust bearing(5-038-0) is adjacent to retainer. Put shaft and bearings into cylinder.

5. Assemble bearing seal (5-177-4) and O-rings (5-914-4) in cover (5-018-4) and mount to bearing cylinder (5-084-0). After tightening screws, an axial clearance of .004"-.015" between outer race of thrust bearing (5-038-0) and spring retainer (5-147-4)should exist. Check this clearance by using pipe tap hole on top of bearing cylinder.

6. Mount bearing seal (5-177-3) and O-rings (5-914-3) in cover (5-018-3) and bolt to bearing cylinder. Mount deflector (5-040-3).

7. If removed from casing, re-install stuffing box (6-073-0) at this time. Install water seal bushing (6-008-0) and mount stuffing box in gland half casing (2-001-0), using two straight dowels to locate the stuffing box.

8. Place bearing cylinder (5-084-0) on pedestal (5-083-0) and bolt straps (5-127-0) into place. Leave bolts slightly loose for later adjustment. Step 12.

9. Install gland side liner (2-174-0). Re-assemble sleeve nut (5-020-3) and mount against shaft shoulder. Mount sleeve (1-009-0). Replace packing (6-924-0) and gland (6-014-0).

10. Screw on impeller (4-002-0).

11. Replace suction side liner (2-714-5) and replace retaining studs finger tight. Replace suction cover (2-091-0) complete with suction sideplate (2-046-5). Secure cover to casing and tighten side liner and sideplate retaining stud nuts. Bolt casing halves together and then recheck above-mentioned nuts for tightness.

12. *See impeller clearance adjustment.* After clearance is established secure all bolts on bearing cylinder straps. Secure adjusting screws.

13. Reconnect suction and discharge piping.

14. Fill bearing cylinder with oil using oil cap (5-530-0) to proper level (see sight glass). Cylinder must be horizontal and level so that both sight glass oil readings are identical. Pack both bearing cover seals with high temperature grease through grease fittings on covers. See LUBRICATION page 2.

IMPELLER CLEARANCE ADJUSTMENT

1. Loosen the bolts clamping down the bearing cylinder or frame liner straps.
2. By means of the adjusting screw, move the bearing cylinder forward until the impeller touches the suction . This is tested by rotating the shaft by hand.
3. The bearing cylinder or frame liner should then be brought back 1/16" so that the impeller will not rub on suction sideplate.
4. Check the rotating element by hand for freedom of rotation.
5. Retighten bearing cylinder straps. By making this adjustment periodically (depending on the rate of wear) original pump efficiency can be maintained

**ASSEMBLY INSTRUCTIONS FOR RIGID RUBBER LINERS
12x10x25 SRL-C, 14x12x29 SRL-C, 16x14x34 SRL-C & 20x18x40 SRL-C**

Suction and gland side liners for pump sizes 12x10x25 SRL-C and larger (with the exception of the "SRL-XT") were redesigned in 1997 to be "rigid". These rigid liners do not require bonding as outlined in previous manuals. The fasteners holding the liners in have been eliminated with the exception of the gland side liners on the 12x10x25 SRL-C and 14x12x29 SRL-C which now require only 4 studs instead of 10 (Figure 1).

An anti-seize compound should be applied to these four studs on the gland side liners and torqued as specified in Figure 1. Sideplate torque specifications and a comparison of fasteners required on rigid liners versus previous design shown in Figures 2 and 3.

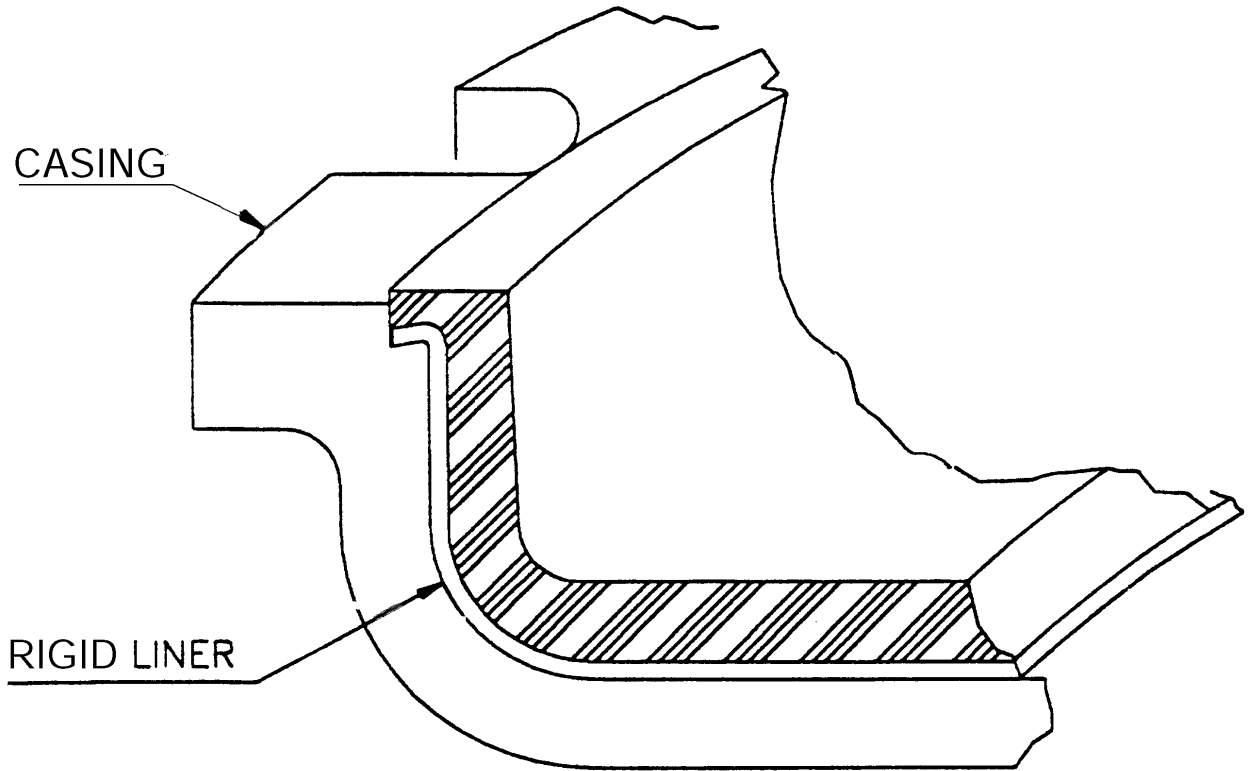
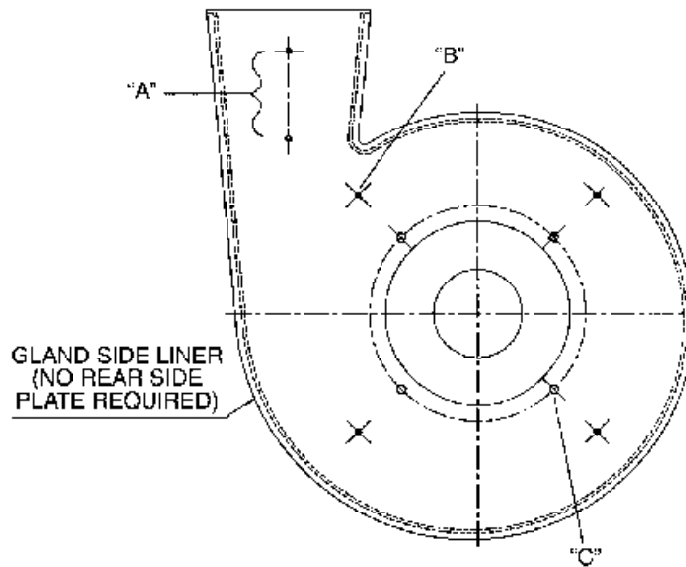

FIGURE 1



"A", "B" & "C" WERE STANDARD ON THESE LINERS BEFORE 1997. RIGID LINERS REQUIRE ONLY "C".

GLAND SIDE PUMP SIZE	"A"	"B"	"C"	TORQUE LIMIT
12x10x25 SRL-C	—	—	QTY 4 .750-10 UNC	30 FT. LBS.
14x12x29 SRL-C	—	—	QTY 4 .875-9 UNC	35 FT. LBS.
16x14x34 SRL-C	—	—	—	
20x18x40 SRL-C	—	—	—	

FIGURE 2

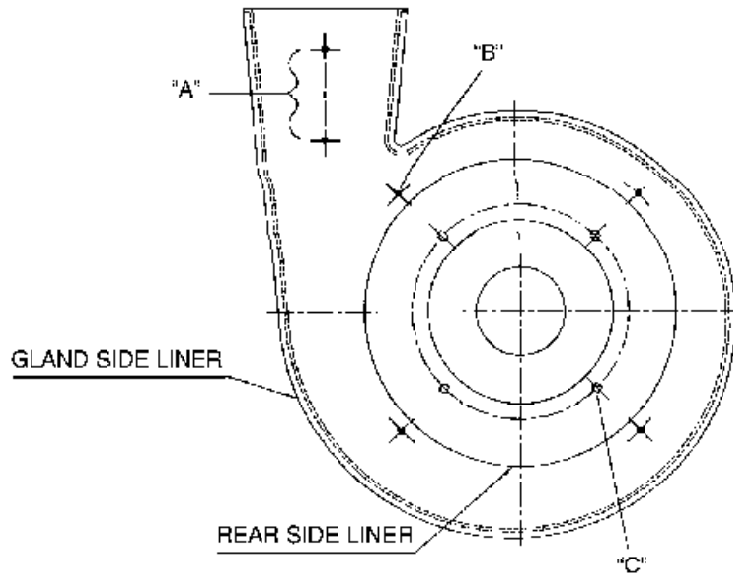

GLAND SIDE PUMP SIZE	"A"	QTY	"B"	"C"	TORQUE LIMIT
16x14x34 SRL-C	"A"	2	.500-13	UNC	30 FT. LBS.
	"B"	4	.500-13	UNC	30 FT. LBS.
	"C" REAR SIDE PLATE	4	1.000-8	UNC	175 FT. LBS.
20x18x40 SRL-C	"A"	2	.750-10	UNC	30 FT. LBS.
	"B"	8	.750-10	UNC	30 FT. LBS.
	"C" REAR SIDE PLATE	4	1.000-8	UNC	175 FT. LBS.

FIGURE 3

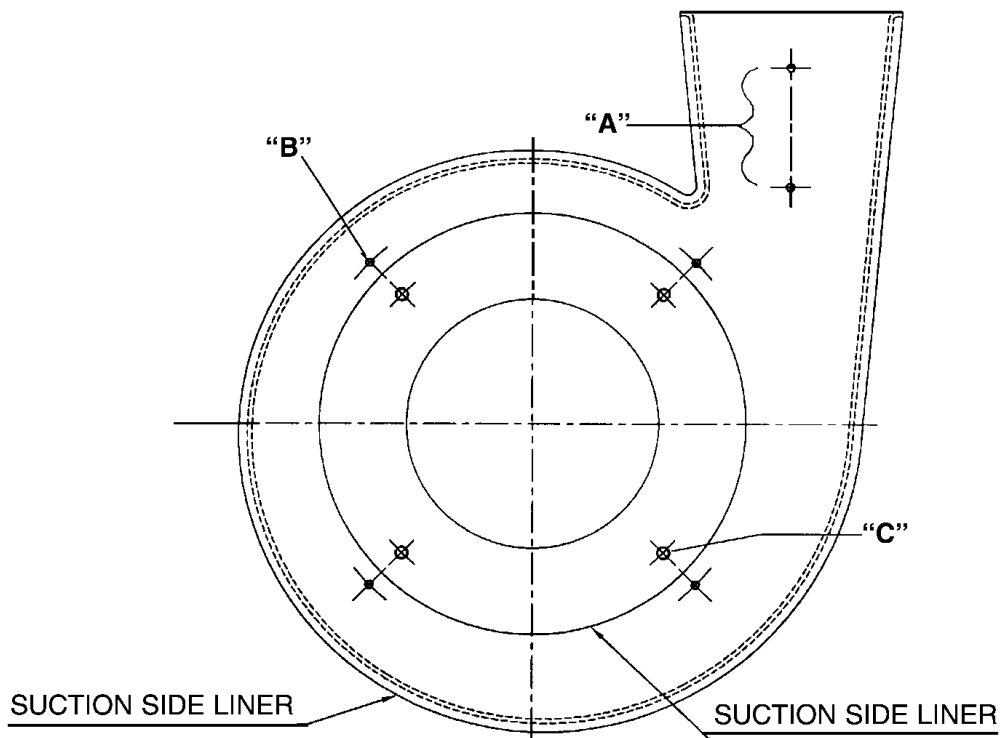

SUCTION SIDE PUMP SIZE							
12x10x25 SRL-C	"A"		—				
	"B"		—				
	"C" SUCT. SIDE PLATE	QTY 4	.750-10	UNC	TORQUE LIMIT	100 FT. LBS.	
14x12x29 SRL-C	"A"		—				
	"B"		—				
	"C" SUCT. SIDE PLATE	QTY 4	.875-9	UNC	TORQUE LIMIT	120 FT. LBS.	
16x14x34 SRL-C	"A"	QTY 2	.500-13	UNC	TORQUE LIMIT	30 FT. LBS.	
	"B"	QTY 4	.500-13	UNC	TORQUE LIMIT	30 FT. LBS.	
	"C" SUCT. SIDE PLATE	QTY 4	1.000-8	UNC	TORQUE LIMIT	175 FT. LBS.	
20x18x40 SRL-C	"A"	QTY 2	.750-10	UNC	TORQUE LIMIT	30 FT. LBS.	
	"B"	QTY 8	.750-10	UNC	TORQUE LIMIT	30 FT. LBS.	
	"C" SUCT. SIDE PLATE	QTY 4	1.000-8	UNC	TORQUE LIMIT	175 FT. LBS.	

BEARING OIL REQUIREMENTS

SIZE	MODEL	IMP. QUARTS	US QUARTS	LITERS
2x2x10	SRL	0.31	0.38	0.36
3x3x10	SRL	0.40	0.48	0.45
3x3x10	SRL-C	0.40	0.48	0.45
5x4x14	SRL-C	0.60	0.72	0.68
5x5x14	SRL	0.60	0.72	0.68
6x6x15	SRL	0.60	0.72	0.68
8x6x18	SRL-C	2.50	3.00	2.84
10x8x21	SRL-C	2.50	3.00	2.84
12x10x25	SRL-C	5.35	6.43	6.08
14x12x29	SRL-C	5.50	6.61	6.25
16x14x34	SRL-C	8.60	10.33	9.77
20x18x40	SRL-C	13.80	16.57	15.68
6x6x21	SRL-XT	2.50	3.00	2.84
8x8x25	SRL-XT	5.35	6.43	6.08
10x10x28	SRL-XT	5.50	6.61	6.25
14x12x36	SRL-XT	8.90	10.69	10.11

Goulds Pumps



ITT Industries