

MAINTENANCE MANUAL
FLAPPER VALVE DIAPHRAGM PUMPS
NDP-50FAN

WARNING



- For your own safety, be sure to read these procedures carefully before performing maintenance on this product. After reading this document, be sure to keep it handy for future reference.

This maintenance manual covers what you should know about maintenance of the Yamada NDP-50FAN Diaphragm Pumps.

This edition is based on the standards for the March 2009 production run. Remember, the specifications are always subject to change; therefore, some of the information in this edition may not apply to new specifications.

Warnings and Cautions

For safe use of this product, be sure to note the following: In this document, warnings and cautions are indicated by symbols. These symbols are for those who will operate this product and for those who will be nearby, for safe operation and for prevention of personal injury and property damage. The following warning and caution symbols have the meanings described below. Be sure to remember their meanings.



WARNING : If you ignore the warning described and operate the product in an improper manner, there is danger of serious bodily injury or death.



CAUTION : If you ignore the caution described and operate the product in an improper manner, there is danger of personal injury or property damage.

Furthermore, to indicate the type of danger and damage, the following symbols are also used along with those mentioned above:



This symbol indicates a DON'T, and will be accompanied by an explanation on something you must not do.



This symbol indicates a DO, and will be accompanied by instructions on something you must do in a certain situation.

WARNING



- Before starting maintenance work, cut off the feed air and clean the pump. If air pressure or residue remain in the pump, there is danger of explosion, or possible poisoning resulting in serious injury or death if chemicals adhere to the skin or are accidentally swallowed. (For details on cleaning the pump, refer to Chapter 6 of the operating manual.)
- When replacing parts, be sure to use the recommended genuine parts or Equivalents. Use of other parts may cause a malfunction of the product.

CAUTION



- When it is instructed that special tools must be used, be sure to use the specified tools. Otherwise, the pump may be damaged.
- Refer to 10.1 "Specifications" in the Operating Manual. Also, remember that the pump is heavy, and extreme care must be taken when lifting it.

Table of Contents

·Warnings and Cautions	
·Table of Contents	
1.Principles of operation-----	1
2.Tools, etc.	
2.1 General tools -----	1
2.2 Special tools -----	1
2.3 Misc. -----	1
3.Ordering Replacement parts -----	1
4.Valve assembly (Flap valve, Valve seats)	
4.1 Removal -----	2
4.2 Inspection -----	3
4.3 Installation-----	3
5.Diaphragm and Center rod	
5.1 Removal -----	4
5.2 Inspection -----	5
5.3 Installation -----	5
6.Throat bearing and Pilot valve	
6.1 Removal -----	6
6.2 Inspection -----	6
6.3 Installation-----	6
7.C Spool valve assembly	
7.1 Removal -----	7
7.2 Inspection -----	8
7.3 Installation-----	8
8.Retightening of Tie rods-----	9
9.Exploded View and Parts List	
9.1 NDP-50FAN-----	10
9.2 BODY ASSEMBLY-----	12
9.3 VALVE BODY ASSEMBLY -----	13
9.4 VALVE ASSEMBLY -----	14

1.Principles of operation

There are two diaphragms fixed to the center rod, one at each end. When compressed air is supplied to air chamber b (right side, see Fig. 1.1), the center rod moves to the right, the material in material chamber B is pushed out, and at the same time material is sucked into material chamber A.

When the center rod is moved full-stroke to the right, the air switch valve is switched, compressed air is sent to air chamber a (left side, see Fig.1.2), and the center rod moves to the left. The material in material chamber A is pushed out, and at the same time material is sucked into material chamber B. Through repetition of this operation, material is repeatedly taken in and discharged out.

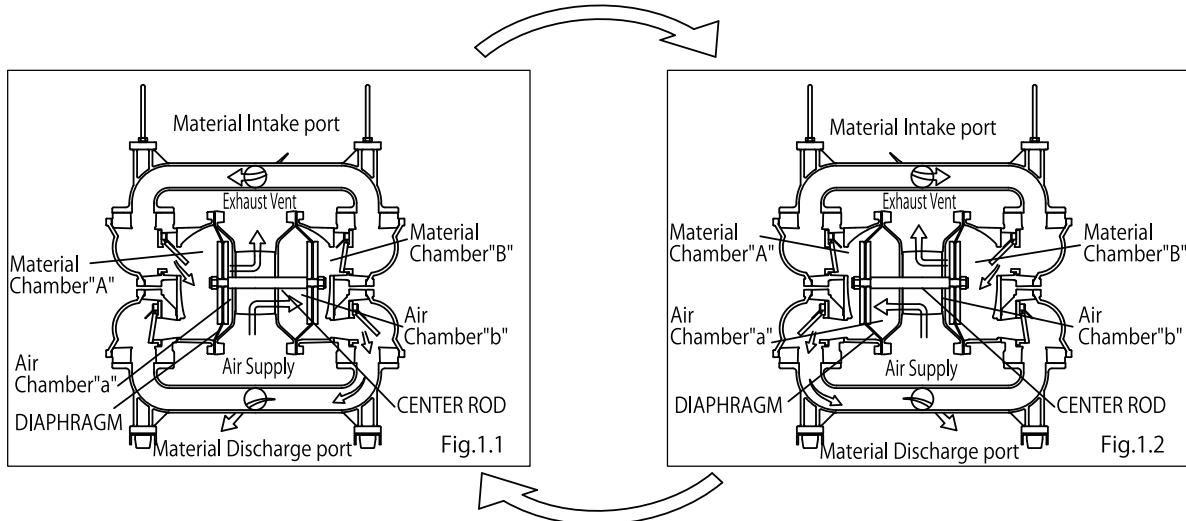

2.Tools, etc.

2.1 General tools

- Socket wrenches 10 mm, 13mm, 17mm, 19mm, 24mm
- Hexagonal box wrenches 5mm, 6mm, 8mm, 1/4inch
- Small crowbars 2
- Open-end wrenches 10mm, 17mm, 19mm, 24mm
- Plastic hammer

2.2 Special tools

- Sleeve remover (sold separately)
Purpose: For removing sleeve

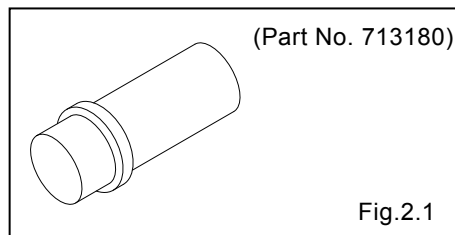

2.3 Misc.

- Assembly oil Turbine oil none addition class 1 (equivalent to ISO VG32 grade)
- Nuts M16 X 1.5
- Grease Urea grease grade (NLGI) No. 2

3.Ordering Replacement parts

For accurate and speedy shipment of parts, be sure to order the right parts for your model to distributor. Indicate the part numbers, descriptions, and quantities.

4. Valve assembly (Flap valve, Valve seats)

4.1 Removal

See [9. Exploded View] on after p.10.

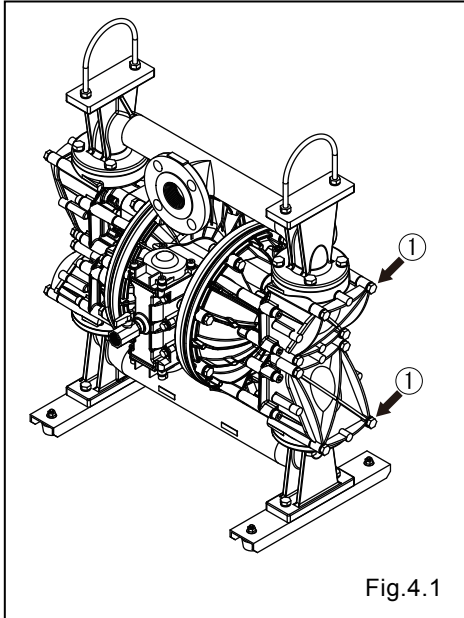

- Remove 4 bolts 1 from the cover, and remove the cover. [Fig.4.1]

< NOTE >

There is parallel only at valve case(out) (bottom side).

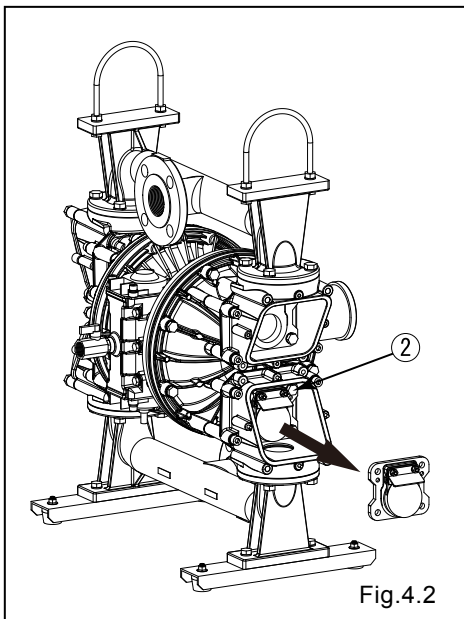

- Remove 4 bolts 2 from the valve assembly, and remove the valve assembly. [Fig.4.2]

4.2 Inspection

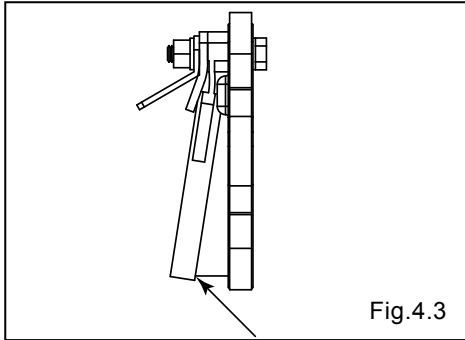

- If there is a gap between the flap valve and valve seat, replace it. [Fig.4.3]

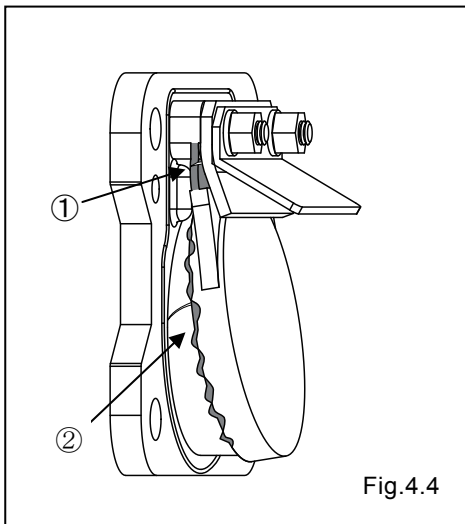

- If 1 or 2 are broken or cracked, replace it.

Guideline of lifetime for Flap valve and Valve seat
2,500,000 cycle
(When used with clean water at room temperature)

4.3 Installation

For installation, see [9. Exploded View] on after p.10, and install in the reverse order of disassembly.

Tightening torque for Valve assembly installation bolts
22 ft-lbf {30 N-m}

Cover assembly installation bolts
22 ft-lbf {30 N-m}

5.Diaphragm and Center rod

5.1 Removal

See [9. Exploded View] on after p.13. (Fig. 5.1 shows the NDP-50 BS_.)

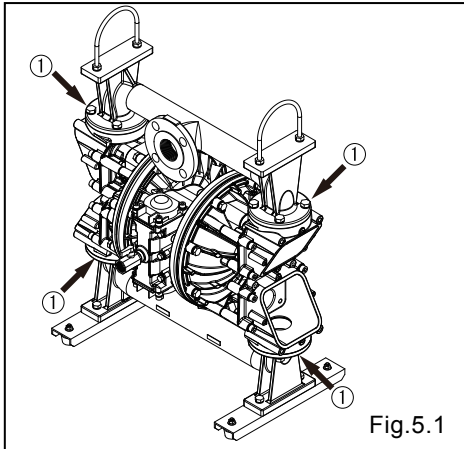

- Remove the cover, valve assembly, etc. (see [4.1 Removal] on p. 2)
- Remove the silencer.
- Replace 16 bolts 1 from the manifold, and remove the manifold and the O ring. [Fig.5.1]

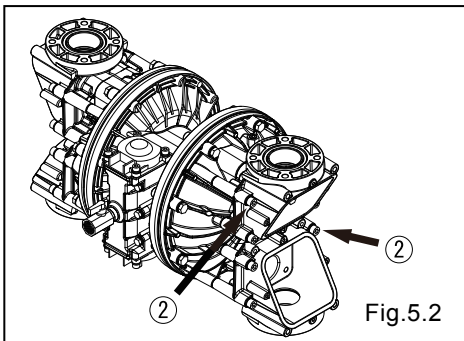

- Remove each 4 bolts 2 from the valve case(IN) and the valve case(OUT), and remove the valve case(IN), the valve case(OUT), the O ring and the gasket. [Fig.5.2]

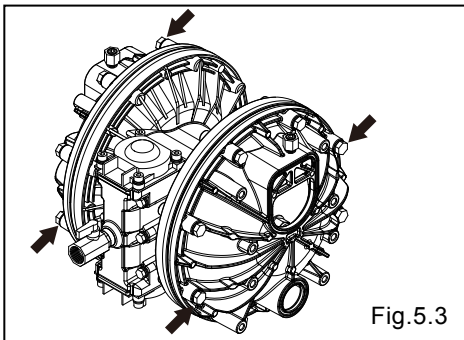

- Remove the 16 retainer bolts from the out chamber, and remove the out chamber. [Fig.5.3]

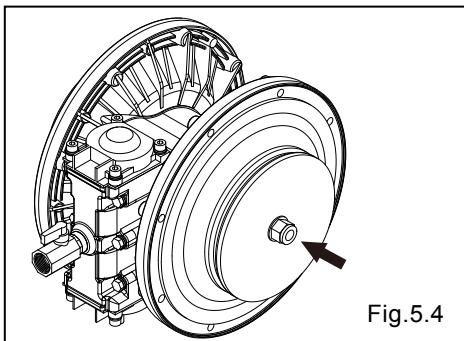

- Remove the nuts on both sides of the center rod. [Fig.5.4]
- Remove the center disk and center rod from the opposite side of the main body.

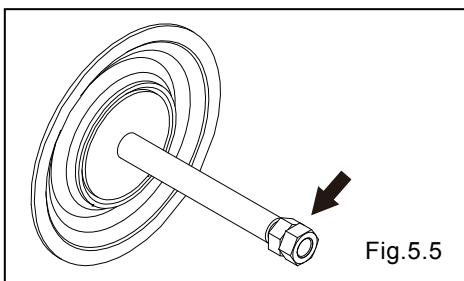

- Fix a double nut to one end of the center rod and take the diaphragm and center disk off the oppsite end. [Fig.5.5]

5.2 Inspection

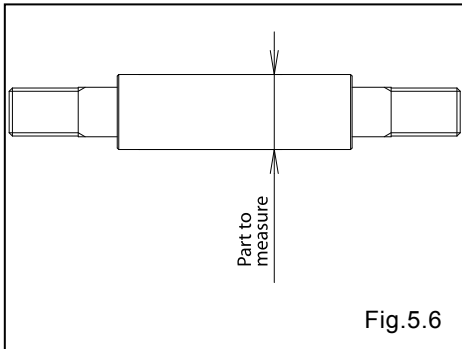

- Diaphragm
If the diaphragm is worn out or damaged, replace it.
New replace just one diaphragm.

Guideline of diaphragm life

10,000,000 cycle

- Center rod [Fig.5.6]
Measure the diameter, and if it is outside the usable range, replace the rod.

Usable range of center rod

$\varnothing 0.9815 \sim \varnothing 0.9843$ in { $\varnothing 24.93 \sim \varnothing 25.00$ mm}

5.3 Installation

For installation, see [9. Exploded View] on after p.10

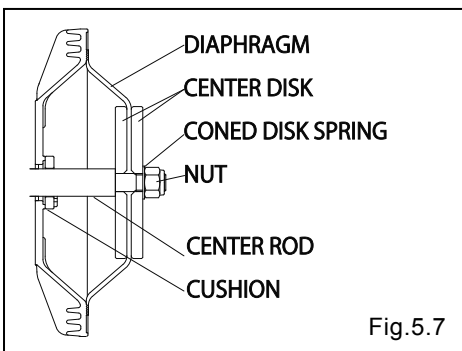

- Apply assembly grease to center rod, and insert it into the main body.
- Insert the cushion. [Fig.5.7]
- Keep the marking "OUTSIDE" to liquid end for diaphragms.

Tightening torque for center rod

43 ft-lbf {60 N-m}

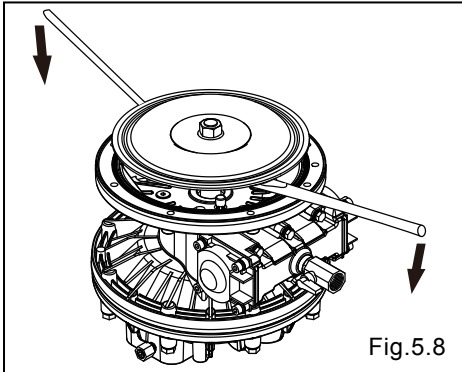

- Draw the center disk to one side and install the out chamber. [Fig.5.9].
- Grip the inside center disk using crowbars and draw it to the opposite side, then turn the diaphragm over. [Fig.5.8, Fig.5.9]
- And install the out chamber.
- Install the valve case(IN) and the valve case(OUT). Tighten the bolts temporarily.
- Place the pump on a flat surface and level mounting surface of the manifold, and tighten the bolts with required torque listed below.

Tightening for out chamber

26 ft-lbf {35 N-m}

Tightening for valve case in out

22 ft-lbf {30 N-m}

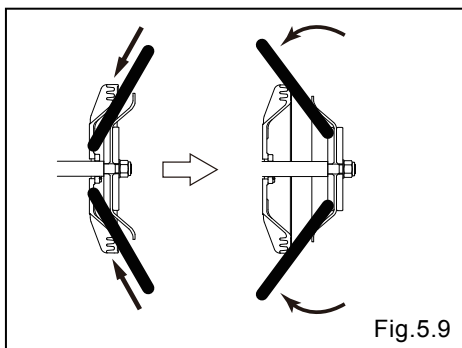

<NOTE>

- Make sure there is no dust on the seal surface in order to prevent seal damaged.
- Be careful not to damage the R portion of the air chamber using a crowbar, etc.
- Tighten the bolts gradually in a diagonal sequence with even torque. [Fig.5.10].

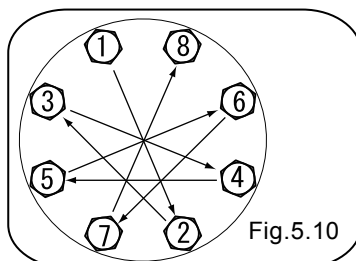

6. Throat bearing and Pilot valve assembly

6.1 Removal

See [9. Exploded View] on after p.10.

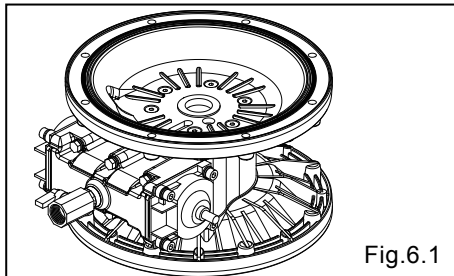

- Remove the diaphragm and center rod. (see [5.1 Removal] on p.4).
- Remove the 12 retainer bolts from the air chamber, and remove the air chamber. [Fig.6.1]

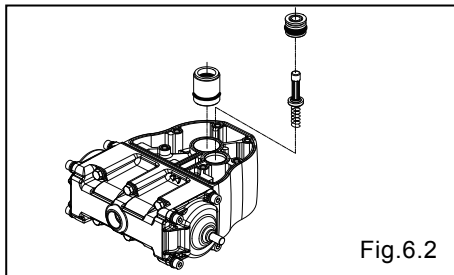

- Draw out the pilot valve and valve seat. [Fig.6.2]
- Draw out the throat bearing. [Fig.6.2]

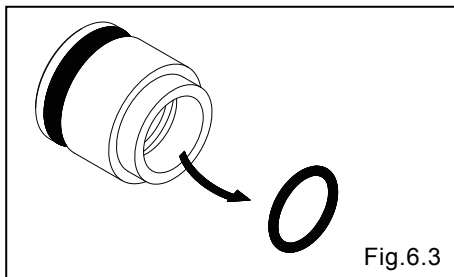

- Remove the packing from the throat bearing. [Fig.6.3]

6.2 Inspection

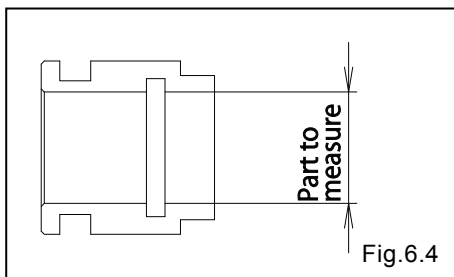

- Throat bearing [Fig.6.4]
Measure the inside diameter, and if it is outside the usable range, replace the throat bearing

Usable range of throat bearing

$\varnothing 0.9859 \sim \varnothing 0.9894$ in { $\varnothing 25.04 \sim \varnothing 25.13$ mm}

- O ring, Packing
If the O ring is worn out or cracked, replace it.
- Pilot valve
If the pilot valve is worn out or cracked, replace it.

6.3 Installation

For installation, see [9. Exploded View] on after p.10, and install in the reverse order of disassembly.

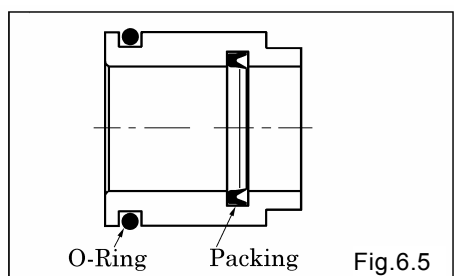

Tightening torque for air chamber retainer bolts

15 ft-lbf {20 N-m}

<NOTE>

- Make sure there is no dust on the seal surface and the seal is not damaged.
- Apply grease to packing.

7.C spool valve assembly

7.1 Removal

See [9. Exploded View] on after p.10.

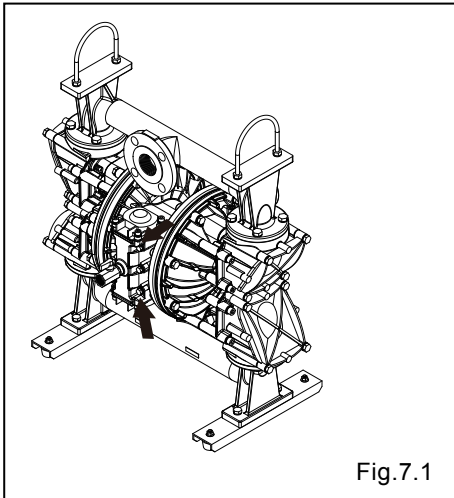

- Remove the 6 retainer bolts from the valve body, and remove the valve body. [Fig.7.1]

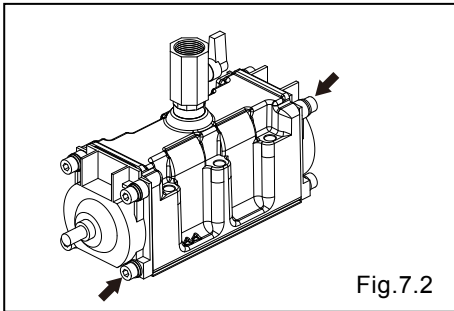

- Remove the 8 cap A and cap B retainer bolts, and remove cap A and cap B. [Fig.7.2]

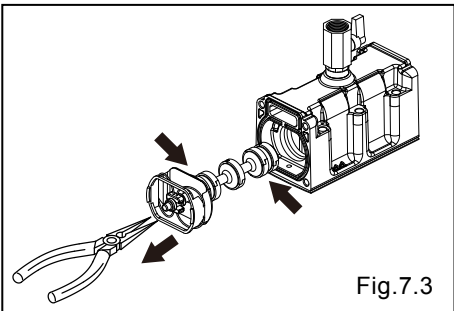

- Draw out the C spool valve assembly, and remove the seal ring from the C spool valve assembly.
- Remove the spring stopper. [Fig.7.3]

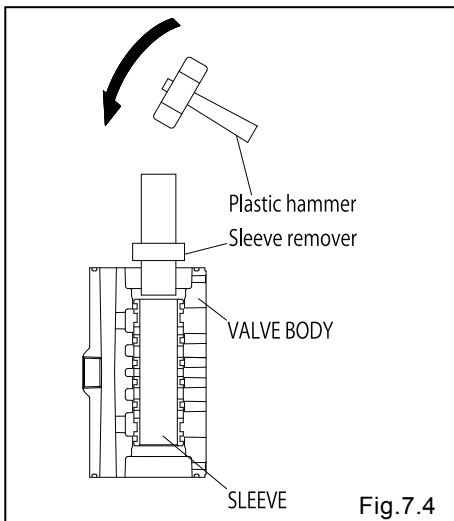

- Remove the sleeve using the sleeve remover (special tool: Part number 713180). [Fig.7.4]

7.2 Inspection

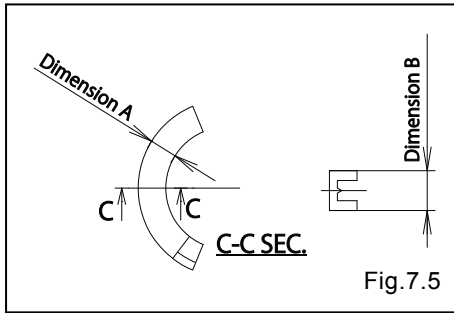

Fig.7.5

▪ C Spool Valve Assembly

▪ Seal ring [Fig.7.5]

Measure dimensions A and B, and if there is sufficient wear to require replacement, replace the c spool valve assembly.

If the seal ring is worn out or cracked, replace c spool valve assembly.

Usable range of seal ring

Dimension A	More than 0.1988 in {5.05 mm}
Dimension B	More than 0.2874 in {7.30 mm}

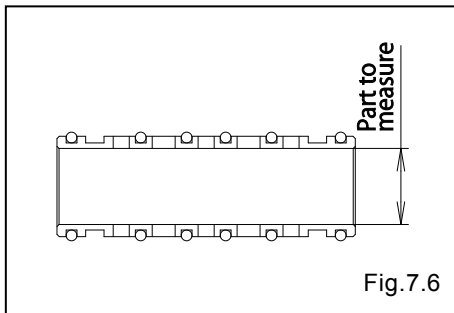

Fig.7.6

▪ Sleeve Assembly[Fig.7.6]

Measure the inside diameter, and if it is outside the usable range, replace the c spool valve assembly.

Usable range of sleeve

$\varnothing 1.305 \sim \varnothing 1.313$ in { $\varnothing 33.15 \sim \varnothing 33.35$ mm}

▪ O ring

If the O ring is worn out or cracked, replace it.

<NOTE>

- C Spool Valve Assembly must be replaced as a complete set. Unable to replace individual component.

7.3 Installation

For installation, see [9. Exploded View] on after p.10 and install in the reverse order of disassembly.

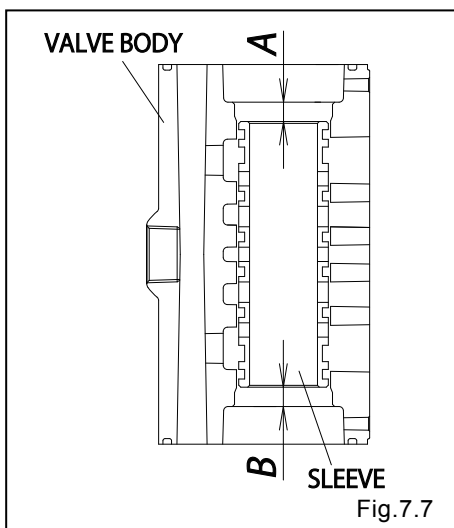

Fig.7.7

- Install the sleeve using the sleeve remover (special tool: Part No. 713180). At this point, apply assembly oil around the sleeve and O ring.

- Install the sleeve at the center of the valve body.

(A = B)

Tightening torque for installation cap A, cap B

8 ft-lbf {10 N-m}

Tightening torque for valve body installation bolts

12 ft-lbf {17 N-m}

<NOTE>

- Make sure there is no dust on the seal surface and it is not damaged.

8. Retightening of Tie rods

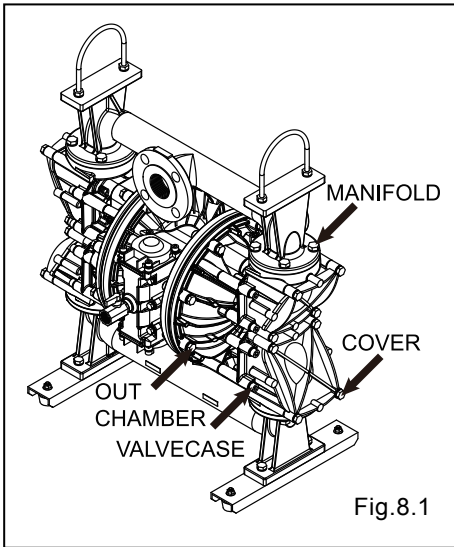

- All bolts should be retorqued:
 - (1) Right before start up.
 - (2) There are any leaks of material on daily inspecting a pump.

NDP-50FAN	Retain bolts for the out chamber.	Cover Valve case in Valve case out	Retain bolts for the manifold.
	26 ft-lbf {35 N-m}	22 ft-lbf {30 N-m}	15 ft-lbf {20 N-m}

<NOTE>

- Retighten the Out chamber and then the manifold in this order. [Fig.8.1]
- Tighten the bolts in the order shown. [Fig.8.2]

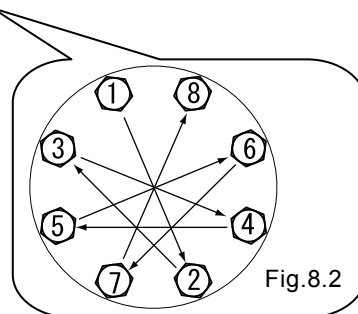

9. Exploded View and Parts List
9.1 Exploded View ■ **NDP- 50FAN**

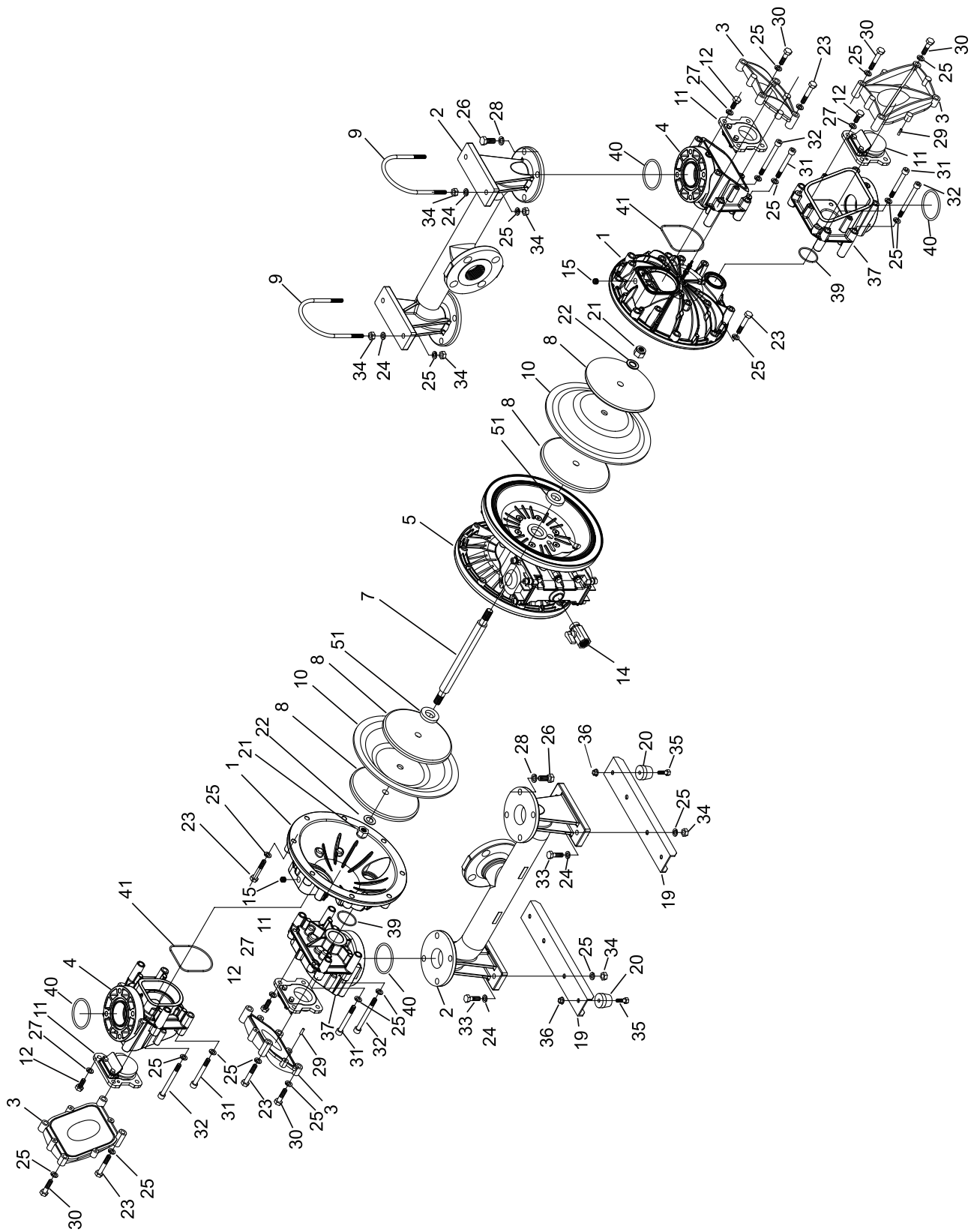

9.1 Parts List

■ NDP-50FAN

NO.	50FAN	DESCRIPTION	Q'TY	NOTE
1	716032	OUT CHAMBER	2	
2	715767	MANIFOLD	2	
3	795117	COVER	4	
4	716030	VALVE CASE (IN)	2	
5	804719	BODY ASSEMBLY	1	
7	711900	CENTER ROD	1	
8	711904	CENTER DISK	4	
9	686099	U BOLT	2	
10	771702	DIAPHRAGM	2	
11	804602	VALVE ASSEMBLY	4	
12	621173	BOLT	16	M10 x 1.5 x 25
14	684322	VALVE	1	3/4
15	686100	PLUG	2	1/4
19	716078	BASE	2	1/4
20	711402	CUSHION	4	
21	683408	NUT	2	
22	682740	CONED DISK SPRING	2	
23	686045	BOLT	24	M10 x 1.5 x 60
24	631014	PLAIN WASHER	8	
25	631917	WAVE SPRING WASHER	32	
26	611197	BOLT	16	M12 x 1.75 x 30
27	631937	WAVE SPRING WASHER	16	SUS
28	631918	WAVE SPRING WASHER	16	
29	686169	PARALLEL PIN	8	
30	611179	BOLT	8	M10 x 1.5 x 40
31	619188	HEXAGON SOCKET HEAD CAP SCREW	8	M10 x 1.5 x 85
32	686158	HEXAGON SOCKET HEAD CAP SCREW	8	M10 x 1.5 x 105
33	611177	BOLT	4	M10 x 1.5 x 35
34	627013	NUT	12	M10 x 1.5
35	611149	BOLT	4	M8 x 1.25 x 25
36	682276	NUT WITH FLANGE	4	M8 x 1.25
37	716031	VALVE CASE (OUT)	2	
39	640045	O RING	2	P48
40	640060	O RING	4	P70
41	772941	GASKET	2	
50	790921	NAME PLATE	1	
51	770582	CUSHION	2	

NOTE 1)NO.50(NAME PLATE) IS NOT INDICATED IN EXPLODED VIEW.

2)NO.23(BOLT) IS COMPOSED OF BOLT(686162)AND WAVE SPRING WASHER(631917)

9.2 Exploded View

■ BODY ASSEMBLY

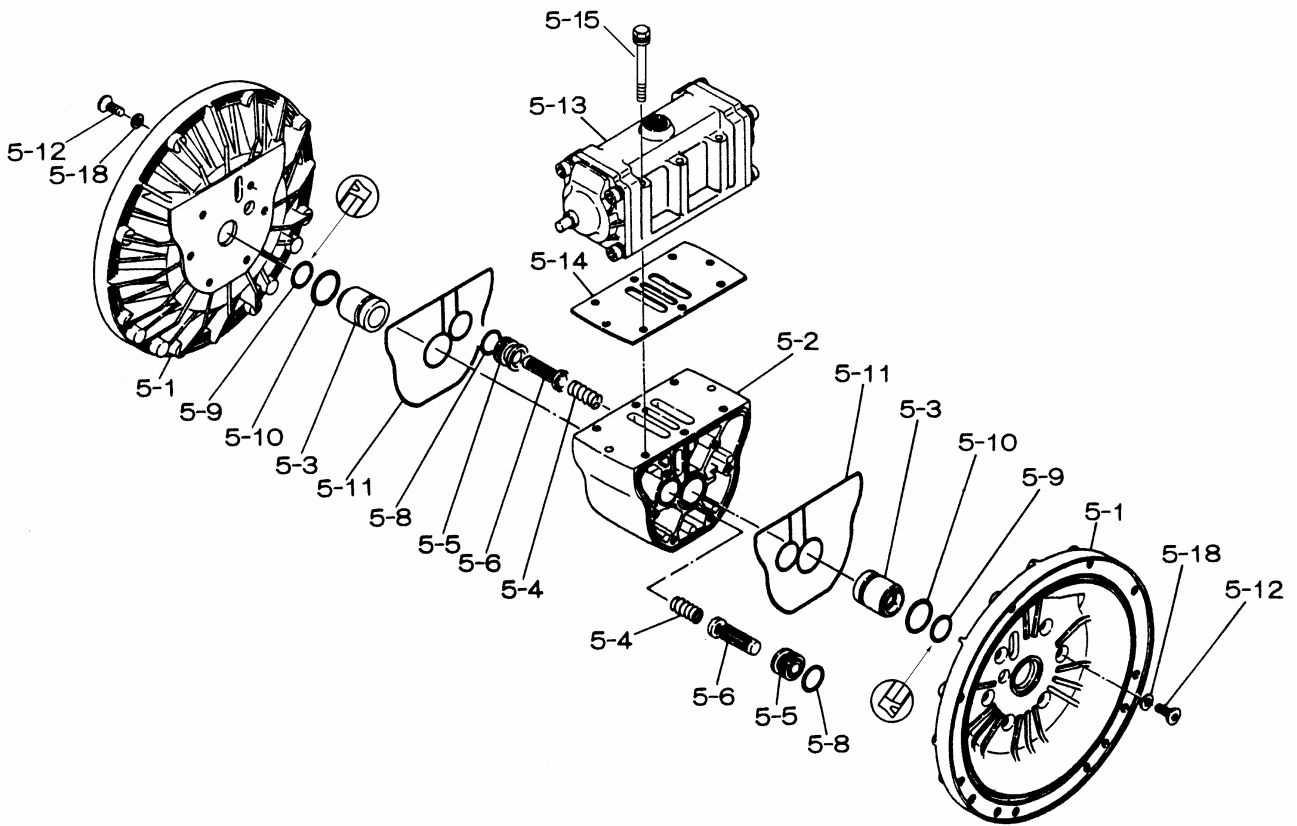

9.2 Parts List

■ BODY ASSEMBLY

BODY ASSEMBLY

NO.	NDP-50FAN	DESCRIPTION	Q'TY	NOTE
5-1	711934	AIR CHAMBER	2	
5-2	711936	BODY	1	
5-3	772689	THROAT BEARING	2	
5-4	711937	SPRING	2	
5-5	771740	VALVE SEAT	2	
5-6	832163	PILOT VALVE ASSEMBLY	2	
5-8	640020	O RING	2	P22A NBR
5-9	685444	PACKING	2	PNY-25
5-10	640029	O RING	2	P30 NBR
5-11	771742	GASKET	2	
5-12	683812	FLAT HEAD BOLT	12	M8x1.25x20
5-13	802971	VALVE BODY ASSEMBLY	1	
5-14	771712	GASKET	1	
5-15	684240	BOLT	6	M8x1.25x85
5-18	684987	PLAIN WASHER	12	

9.3 Exploded View

■ VALVE BODY ASSEMBLY

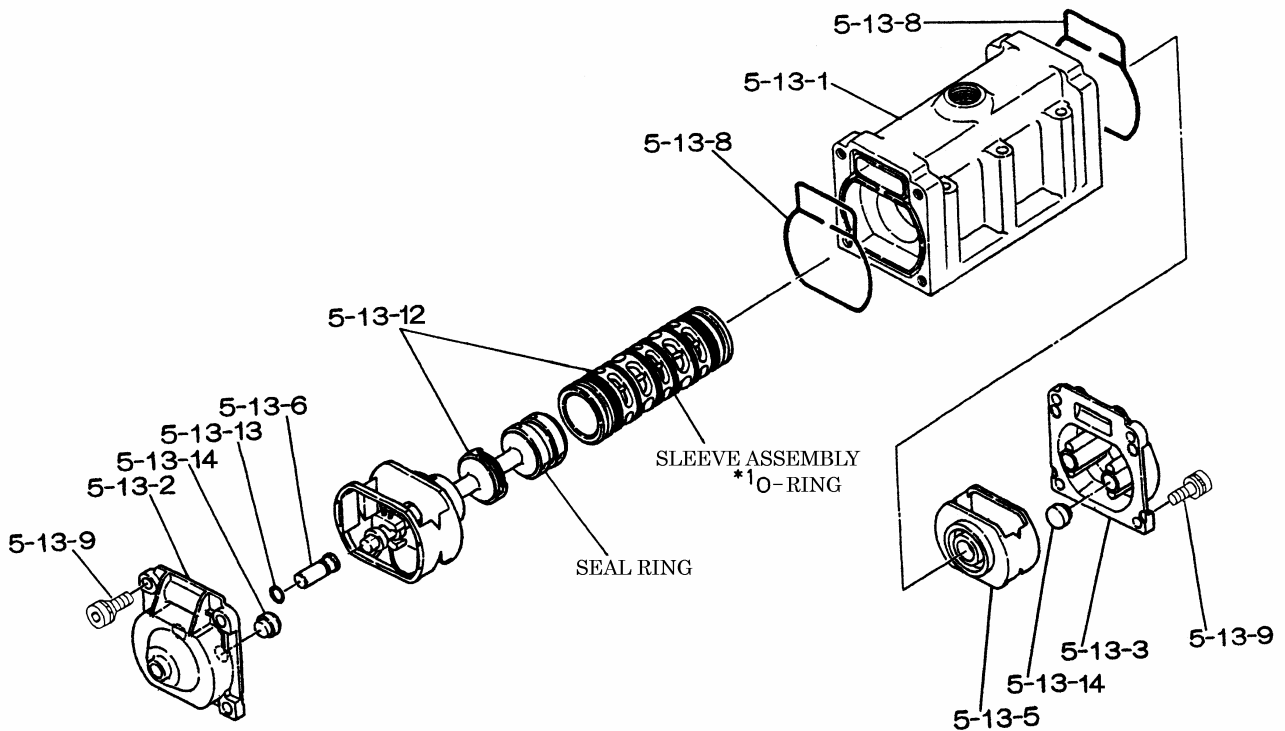

9.3 Parts List

■ VALVE BODY ASSEMBLY

802971 VALVE BODY ASSEMBLY

NO.	PART NO.	DESCRIPTION	Q'TY	NOTE
5-13-1	711931	VALVE BODY	1	
5-13-2	580999	CAP A	1	
5-13-3	581000	CAP B	1	
5-13-5	771735	SPRING RETAINER	1	
5-13-6	712976	RESET BUTTON	1	
5-13-8	771738	GASKET	2	
5-13-9	685036	HEXAGON SOCKET HEAD BOLT	8	M8 x 1.25 x 20
5-13-12	803115	C SPOOL VALVE ASSEMBLY	1	* ¹ (640036)
5-13-13	640005	O RING	1	P8 NBR
5-13-14	684128	CUSHION	4	

NOTE)*1: PARTS NUMBER MENTIONED ON O RING FOR SLEEVE ASSEMBLY ONLY.

9.4 Exploded View

■ VALVE ASSEMBLY

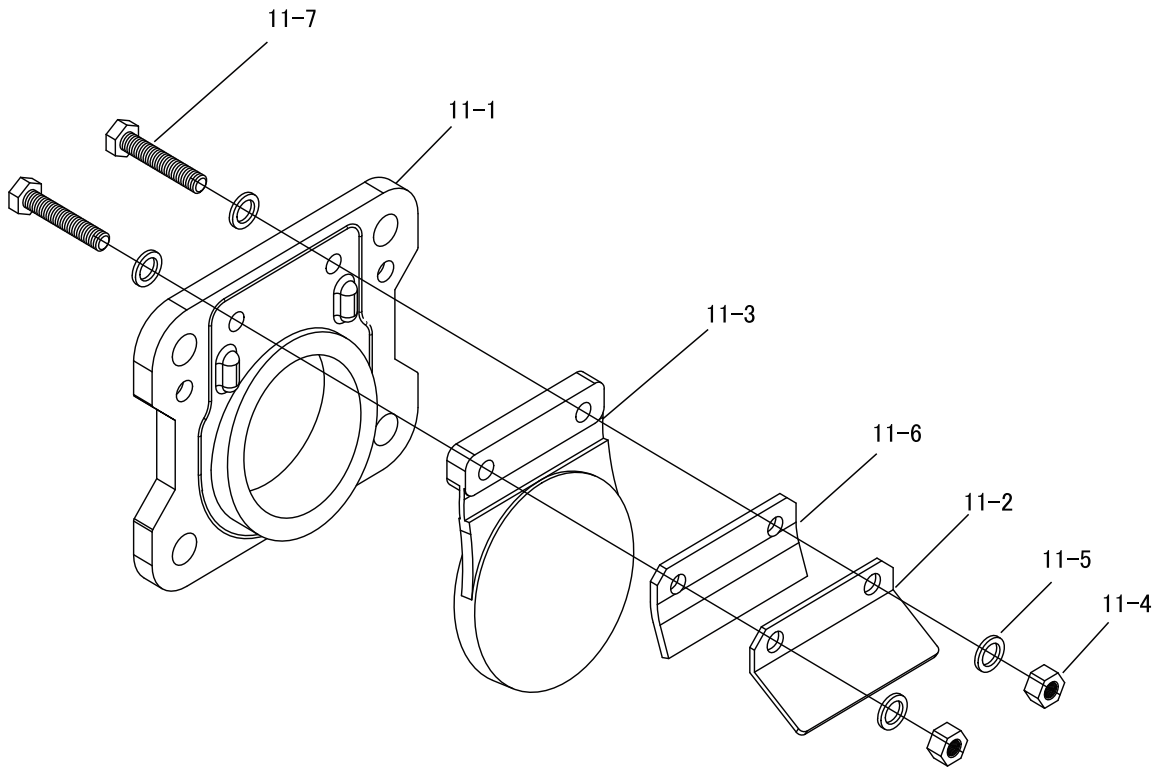

9.4 Parts List

■ VALVE ASSEMBLY

804602 VALVE ASSEMBLY

NO.	PART NO.	DESCRIPTION	Q'TY	NOTE
11-1	795115	VALVE SEAT	1	
11-2	715765	VALVE STOPPER	1	
11-3	795116	FLAP VALVE	1	
11-4	685184	NUT	2	M6 x 1
11-5	631172	PLAIN WASHER	4	
11-6	773000	HINGE PAD	1	
11-7	621106	BOLT	2	M6 x 1x 32

YAMADA AMERICA, INC

955 E. ALGONQUIN RD., ARLINGTON HEIGHTS, IL 60005, USA
PHONE: 1-847-631-9200 or 1-800-990-7867 (Toll Free) FAX : 1-847-631-9273
www.yamadapump.com

Manufactured by:

YAMADA CORPORATION

International Department
1-1-3 CHOME, MINAMI MAGOME, OHTA-KU, TOKYO, 143-8504, JAPAN
PHONE : +81-(0)3-3777-0241 FAX : +81-(0)3-3777-0584

200907 NDP287M