

# **GOULDS PUMPS**

## **Installation, Operation and Maintenance Instructions**



**Model JC**



**ITT**

**This page intentionally left blank.**

# TABLE OF CONTENTS

PAGE		SECTION
7		SAFETY 1
11		GENERAL INFORMATION 2
13		INSTALLATION 3
17		OPERATION 4
21		PREVENTIVE MAINTENANCE 5
27		SPARE PARTS 6
31		APPENDIX 7

**This page intentionally left blank.**

## IMPORTANT SAFETY NOTICE

*To: Our Valued Customers*

User safety is a major focus in the design of our products. Following the precautions outlined in this manual will minimize your risk of injury.

ITT Goulds pumps will provide safe, trouble-free service when properly installed, maintained, and operated.

Safe installation, operation, and maintenance of ITT Goulds Pumps equipment are an essential end user responsibility. This *Pump Safety Manual* identifies specific safety risks that must be considered at all times during product life. Understanding and adhering to these safety warnings is mandatory to ensure personnel, property, and/or the environment will not be harmed. Adherence to these warnings alone, however, is not sufficient — it is anticipated that the end user will also comply with industry and corporate safety standards. Identifying and eliminating unsafe installation, operating and maintenance practices is the responsibility of all individuals involved in the installation, operation, and maintenance of industrial equipment.

Please take the time to review and understand the safe installation, operation, and maintenance guidelines outlined in this Pump Safety Manual and the Instruction, Operation, and Maintenance (IOM) manual. Current manuals are available at [www.gouldspumps.com/literature\\_ioms.html](http://www.gouldspumps.com/literature_ioms.html) or by contacting your nearest Goulds Pumps sales representative.

**These manuals must be read and understood before installation and start-up.**

For additional information, contact your nearest Goulds Pumps sales representative or visit our Web site at [www.gouldspumps.com](http://www.gouldspumps.com).

# SAFETY WARNINGS

Specific to pumping equipment, significant risks bear reinforcement above and beyond normal safety precautions.

---

 **WARNING**

---

A pump is a pressure vessel with rotating parts that can be hazardous. Any pressure vessel can explode, rupture, or discharge its contents if sufficiently over pressurized causing death, personal injury, property damage, and/or damage to the environment. All necessary measures must be taken to ensure over pressurization does not occur.

---

 **WARNING**

---

Operation of any pumping system with a blocked suction and discharge must be avoided in all cases. Operation, even for a brief period under these conditions, can cause superheating of enclosed pumpage and result in a violent explosion. All necessary measures must be taken by the end user to ensure this condition is avoided.

---

 **WARNING**

---

The pump may handle hazardous and/or toxic fluids. Care must be taken to identify the contents of the pump and eliminate the possibility of exposure, particularly if hazardous and/or toxic. Potential hazards include, but are not limited to, high temperature, flammable, acidic, caustic, explosive, and other risks.

---

 **WARNING**

---

Pumping equipment Instruction, Operation, and Maintenance manuals clearly identify accepted methods for disassembling pumping units. These methods must be adhered to. Specifically, applying heat to impellers and/or impeller retaining devices to aid in their removal is strictly forbidden. Trapped liquid can rapidly expand and result in a violent explosion and injury.

ITT Goulds Pumps will not accept responsibility for physical injury, damage, or delays caused by a failure to observe the instructions for installation, operation, and maintenance contained in this Pump Safety Manual or the current IOM available at [www.gouldspumps.com/literature](http://www.gouldspumps.com/literature).

# SAFETY

## DEFINITIONS

Throughout this manual the words **WARNING**, **CAUTION**, **ELECTRICAL**, and **ATEX** are used to indicate where special operator attention is required.

**Observe all Cautions and Warnings highlighted in this Pump Safety Manual and the IOM provided with your equipment.**



### **WARNING**

Indicates a hazardous situation which, if not avoided, could result in death or serious injury.

**Example:** Pump shall never be operated without coupling guard installed correctly.

---



### **CAUTION**

Indicates a hazardous situation which, if not avoided, could result in minor or moderate injury.

**Example:** Throttling flow from the suction side may cause cavitation and pump damage.

---



### **ELECTRICAL HAZARD**

Indicates the possibility of electrical risks if directions are not followed.

**Example:** Lock out driver power to prevent electric shock, accidental start-up, and physical injury.

---



When installed in potentially explosive atmospheres, the instructions that follow the Ex symbol must be followed. Personal injury and/or equipment damage may occur if these instructions are not followed. If there is any question regarding these requirements or if the equipment is to be modified, please contact an ITT Goulds Pumps representative before proceeding.







**Example:**  Improper impeller adjustment could cause contact between the rotating and stationary parts, resulting in a spark and heat generation.

---













## GENERAL PRECAUTIONS



### WARNING

A pump is a pressure vessel with rotating parts that can be hazardous. Hazardous fluids may be contained by the pump including high temperature, flammable, acidic, caustic, explosive, and other risks. Operators and maintenance personnel must realize this and follow safety measures. Personal injuries will result if procedures outlined in this manual are not followed. ITT Goulds Pumps will not accept responsibility for physical injury, damage or delays caused by a failure to observe the instructions in this manual and the IOM provided with your equipment.

General Precautions		
WARNING		NEVER APPLY HEAT TO REMOVE IMPELLER. It may explode due to trapped liquid.
WARNING		NEVER use heat to disassemble pump due to risk of explosion from tapped liquid.
WARNING		NEVER operate pump without coupling guard correctly installed.
WARNING		NEVER run pump below recommended minimum flow when dry, or without prime.
WARNING		ALWAYS lock out power to the driver before performing pump maintenance.
WARNING		NEVER operate pump without safety devices installed.
WARNING		NEVER operate pump with discharge valve closed.
WARNING		NEVER operate pump with suction valve closed.
WARNING		DO NOT change service application without approval of an authorized ITT Goulds Pumps representative.
WARNING		<p><b>Safety Apparel:</b></p> <ul style="list-style-type: none"> <li>♦ Insulated work gloves when handling hot bearings or using bearing heater</li> <li>♦ Heavy work gloves when handling parts with sharp edges, especially impellers</li> <li>♦ Safety glasses (with side shields) for eye protection</li> <li>♦ Steel-toed shoes for foot protection when handling parts, heavy tools, etc.</li> <li>♦ Other personal protective equipment to protect against hazardous/toxic fluids</li> </ul>
WARNING		<p><b>Receiving:</b></p> <p>Assembled pumping units and their components are heavy. Failure to properly lift and support equipment can result in serious physical injury and/or equipment damage. Lift equipment only at specifically identified lifting points or as instructed in the current IOM. Current manuals are available at <a href="http://www.gouldspumps.com/literature_ioms.html">www.gouldspumps.com/literature_ioms.html</a> or from your local ITT Goulds Pumps sales representative. Note: Lifting devices (eyebolts, slings, spreaders, etc.) must be rated, selected, and used for the entire load being lifted.</p>
WARNING		<p><b>Alignment:</b></p> <p>Shaft alignment procedures must be followed to prevent catastrophic failure of drive components or unintended contact of rotating parts. Follow coupling manufacturer's coupling installation and operation procedures.</p>



<b>General Precautions</b>		
<b>WARNING</b>		Before beginning any alignment procedure, make sure driver power is locked out. Failure to lock out driver power will result in serious physical injury.
<b>CAUTION</b>		<b>Piping:</b> Never draw piping into place by forcing at the flanged connections of the pump. This may impose dangerous strains on the unit and cause misalignment between pump and driver. Pipe strain will adversely effect the operation of the pump resulting in physical injury and damage to the equipment.
<b>WARNING</b>		<b>Flanged Connections:</b> Use only fasteners of the proper size and material.
<b>WARNING</b>		Replace all corroded fasteners.
<b>WARNING</b>		Ensure all fasteners are properly tightened and there are no missing fasteners.
<b>WARNING</b>		<b>Startup and Operation:</b> When installing in a potentially explosive environment, please ensure that the motor is properly certified.
<b>WARNING</b>		Operating pump in reverse rotation may result in contact of metal parts, heat generation, and breach of containment.
<b>WARNING</b>		Lock out driver power to prevent accidental start-up and physical injury.
<b>WARNING</b>		The impeller clearance setting procedure must be followed. Improperly setting the clearance or not following any of the proper procedures can result in sparks, unexpected heat generation and equipment damage.
<b>WARNING</b>		If using a cartridge mechanical seal, the centering clips must be installed and set screws loosened prior to setting impeller clearance. Failure to do so could result in sparks, heat generation, and mechanical seal damage.
<b>WARNING</b>		The coupling used in an ATEX classified environment must be properly certified and must be constructed from a non-sparking material.
<b>WARNING</b>		Never operate a pump without coupling guard properly installed. Personal injury will occur if pump is run without coupling guard.
<b>WARNING</b>		Make sure to properly lubricate the bearings. Failure to do so may result in excess heat generation, sparks, and / or premature failure.
<b>CAUTION</b>		The mechanical seal used in an ATEX classified environment must be properly certified. Prior to start up, ensure all points of potential leakage of process fluid to the work environment are closed.
<b>CAUTION</b>		Never operate the pump without liquid supplied to mechanical seal. Running a mechanical seal dry, even for a few seconds, can cause seal damage and must be avoided. Physical injury can occur if mechanical seal fails.
<b>WARNING</b>		Never attempt to replace packing until the driver is properly locked out and the coupling spacer is removed.
<b>WARNING</b>		Dynamic seals are not allowed in an ATEX classified environment.
<b>WARNING</b>		<b>DO NOT</b> operate pump below minimum rated flows or with suction and/or discharge valve closed. These conditions may create an explosive hazard due to vaporization of pumpage and can quickly lead to pump failure and physical injury.

<b>General Precautions</b>		
<b>WARNING</b>		Ensure pump is isolated from system and pressure is relieved before disassembling pump, removing plugs, opening vent or drain valves, or disconnecting piping.
<b>WARNING</b>		<b>Shutdown, Disassembly, and Reassembly:</b> Pump components can be heavy. Proper methods of lifting must be employed to avoid physical injury and/or equipment damage. Steel toed shoes must be worn at all times.
<b>WARNING</b>		The pump may handle hazardous and/or toxic fluids. Observe proper decontamination procedures. Proper personal protective equipment should be worn. Precautions must be taken to prevent physical injury. Pumpage must be handled and disposed of in conformance with applicable environmental regulations.
<b>WARNING</b>		Operator must be aware of pumpage and safety precautions to prevent physical injury.
<b>WARNING</b>		Lock out driver power to prevent accidental startup and physical injury.
<b>CAUTION</b>		Allow all system and pump components to cool before handling them to prevent physical injury.
<b>CAUTION</b>		If pump is a Model NM3171, NM3196, 3198, 3298, V3298, SP3298, 4150, 4550, or 3107, there may be a risk of static electric discharge from plastic parts that are not properly grounded. If pumped fluid is non-conductive, pump should be drained and flushed with a conductive fluid under conditions that will not allow for a spark to be released to the atmosphere.
<b>WARNING</b>		Never apply heat to remove an impeller. The use of heat may cause an explosion due to trapped fluid, resulting in severe physical injury and property damage.
<b>CAUTION</b>		Wear heavy work gloves when handling impellers as sharp edges may cause physical injury.
<b>CAUTION</b>		Wear insulated gloves when using a bearing heater. Bearings will get hot and can cause physical injury.

## ATEX CONSIDERATIONS and INTENDED USE

Special care must be taken in potentially explosive environments to ensure that the equipment is properly maintained. This includes but is not limited to:

1. Monitoring the pump frame and liquid end temperature.
2. Maintaining proper bearing lubrication.
3. Ensuring that the pump is operated in the intended hydraulic range.

The ATEX conformance is only applicable when the pump unit is operated within its intended use. Operating, installing or maintaining the pump unit in any way that is not covered in the Instruction, Operation, and Maintenance manual (IOM) can cause serious personal injury or damage to the equipment. This includes any modification to the equipment or use of parts not provided by ITT Goulds Pumps. If there is any question regarding the intended use of the equipment, please contact an ITT Goulds representative before proceeding. Current IOMs are available at [www.gouldspumps.com/literature\\_ioms.html](http://www.gouldspumps.com/literature_ioms.html) or from your local ITT Goulds Pumps Sales representative.

All pumping unit (pump, seal, coupling, motor and pump accessories) certified for use in an ATEX classified environment, are identified by an ATEX tag secured to the pump or the baseplate on which it is mounted. A typical tag would look like this:



The CE and the Ex designate the ATEX compliance. The code directly below these symbols reads as follows:

- II = Group 2
- 2 = Category 2
- G/D = Gas and Dust present
- T4 = Temperature class, can be T1 to T6 (see Table 1)

<b>Code</b>	<b>Max permissible surface temperature °F (°C)</b>	<b>Max permissible liquid temperature °F (°C)</b>
T1	842 (450)	700 (372)
T2	572 (300)	530 (277)
T3	392 (200)	350 (177)
T4	275 (135)	235 (113)
T5	212 (100)	Option not available
T6	185 (85)	Option not available

The code classification marked on the equipment must be in accordance with the specified area where the equipment will be installed. If it is not, do not operate the equipment and contact your ITT Goulds Pumps sales representative before proceeding.

## PARTS



The use of genuine Goulds parts will provide the safest and most reliable operation of your pump. ITT Goulds Pumps ISO certification and quality control procedures ensure the parts are manufactured to the highest quality and safety levels.

Please contact your local Goulds representative for details on genuine Goulds parts.

---

# GENERAL INFORMATION

INTRODUCTION . . . . .	11
IMPORTANCE OF INSTRUCTIONS . . . . .	11
SPECIAL WARNINGS . . . . .	11
RECEIVING INSPECTION - SHORTAGES . . . . .	11

## INTRODUCTION

This instruction manual is intended to assist those involved with the installation, operation and maintenance of Goulds Ashland Operations slurry pumps. It is recommended that this manual be thoroughly reviewed prior to installing or performing any work on the pump or motor.

## IMPORTANCE OF INSTRUCTIONS

The design, material and workmanship incorporated in the construction of Goulds Ashland Operations slurry pumps makes them capable of giving long, trouble-free service. The life and satisfactory service of any mechanical unit, however, is enhanced and extended by periodic inspection

and careful maintenance. This manual was prepared to assist operators in understanding the construction and correct methods of installing, operating, and maintaining these pumps.

## SPECIAL WARNINGS

Goulds Ashland Operations will not be liable for any damages or delay caused by failure to comply with the provisions of this instruction manual. This pump is not to be operated at speeds, working pressures, discharge

pressures, or temperatures higher than, nor used with liquids other than, stated in the original order acknowledgment, without written permission of the Ashland Operations, Goulds Pumps, Inc.

## RECEIVING INSPECTION - SHORTAGES

Care should be taken when unloading pumps. If shipment is not delivered in good order and in accordance with the bill of lading, note the damage or shortage on both receipt and freight bill. **Make any claims to the transportation company promptly.**

**This page intentionally left blank.**

# INSTALLATION

PREPARATION FOR SHIPMENT . . . . .	13
INSTALLATION. . . . .	13
PIPING . . . . .	13
FOUNDATION. . . . .	14
PUMP DRIVER ALIGNMENT. . . . .	15

This section is a general installation and operating instruction for most Goulds pumps. Specific text and illustrations are included in this section. To insure pump performance and operating life, proper installation and

reasonable maintenance are required. The following instructions are a guide for installation and maintenance personnel and the pump operator.

## PREPARATION FOR SHIPMENT

Goulds pumps are prepared at the factory for shipment under covered conditions. They are protected for transport and short term covered storage. Unless otherwise specified,

it is assumed the pump will be installed upon delivery. Additional protection can be provided by request.

## INSTALLATION



### LOCATION OF UNIT



The pump should be located in a clean, dry area free from flooding. The area should provide adequate space for maintenance and repair, considering complete disassembly and handling of equipment. The unit should be positioned to provide the most efficient pipeline system.

 *Equipment that will operate in a potentially explosive environment must be installed in accordance with the following instructions.*

 *All equipment being installed must be properly grounded to prevent unexpected static electric discharge. If not, a static electric discharge may occur when the pump is drained and disassembled for maintenance purposes.*

## PIPING

  **WARNING**  
*Never draw piping into place by forcing at the flanged connections of the pump. This may impose dangerous strains on the unit and cause misalignment between pump and driver. Pipe strain will adversely effect the operation of the pump resulting in physical injury and damage to the equipment*

  **WARNING**  
*NPSHa must always exceed NPSHr as shown on Goulds performance curves received with order. Reference Hydraulic Institute for NPSH and pipe friction values needed to evaluate suction piping*

Short, direct suction and discharge pipelines and a minimum of elbows and fittings result in the least amount of pipe friction.

  **CAUTION**  
*Pump must never be throttled on suction side.*

## SUCTION PIPING

1. Excessive friction losses will cause cavitation.
2. Must be kept free of air leaks, particularly in long lines or conditions of high suction lift.
3. Flow regulating valves must not be located on suction side of the pump.

## DISCHARGE PIPING

1. Excessive friction losses result in insufficient head.
2. A check valve should be located in the discharge line to protect the pump from reverse flow and excessive pressure.

## PIPING SUPPORT

The pumps are not designed to carry loads imposed by the weight of the pipeline. Suction and discharge piping must be supported near the pump, unless otherwise specified. Pumps and subbases can be designed to carry loads due to thermal expansion.

# FOUNDATION

The foundation must be a permanent, rigid support for the subbase or floorplate. It should be an industrially accepted design capable of absorbing excessive vibration. Foundations are typically concrete with anchor bolts cast in to secure the pump.

An anchor bolt assembly consists of a bolt and washer with a sleeve 2-½ times the diameter of the bolt. When the assembly is cast in concrete, the washer prevents the sleeve and bolt from being pulled. The sleeve I.D. provides an adjustment allowance around the bolt. A lug is generally welded on the bolt to prevent rotation when tightening. Anchor bolts should be located in the concrete by a template dimensioned from the pump installation drawing. The top of the sleeve should be temporarily sealed with waste material to prevent concrete from entering during the concrete pouring operation. A typical anchor bolt arrangement is shown in Figure W1.

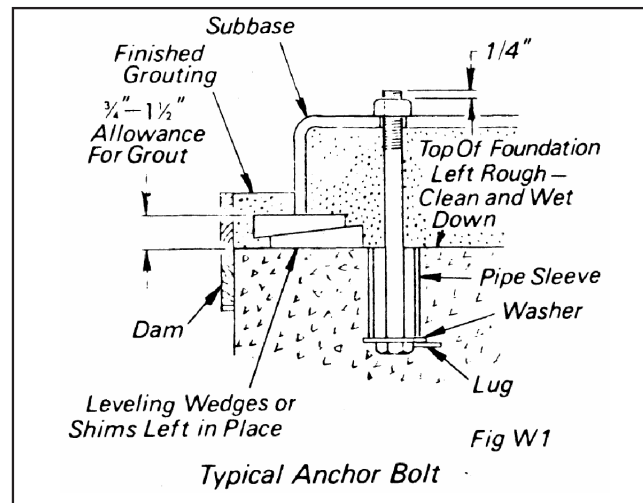

## INSTALLING PUMP ON FOUNDATION

If subbases or floorplates were directly anchored to poured concrete foundations, surface irregularities would cause distortion. Rectangular metal blocks and shims, or metal wedges having a small taper, are placed beside each anchor bolt to level the subbase or floorplate (see Fig. W2 and Fig. W3 on the following page). The anchor bolts are then drawn tight enough to maintain position and level.

To secure the shims in place and provide a level surface for the base or plate, grout is poured over the concrete foundation. A ¾" to 1-½" grout allowance is recommended. When subbases have cavities, grout holes are provided to fill all spaces. After the grout has hardened, permanently tighten the anchor bolts.

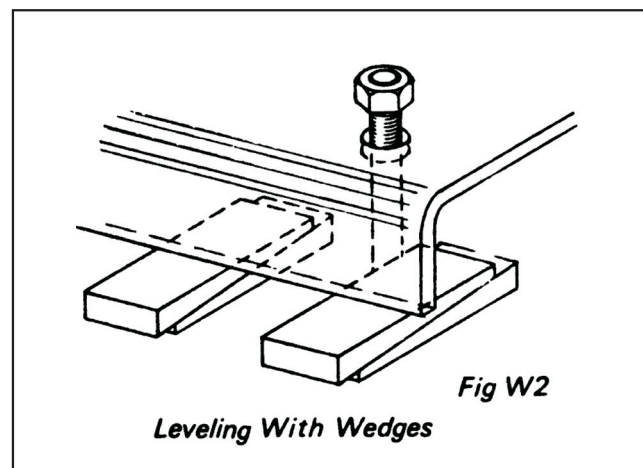



When the grout has hardened and the anchor bolts are permanently secured, recheck level.

**NOTE:** On large subbases/floorplates, shimming is recommended to be at 24" spacing.

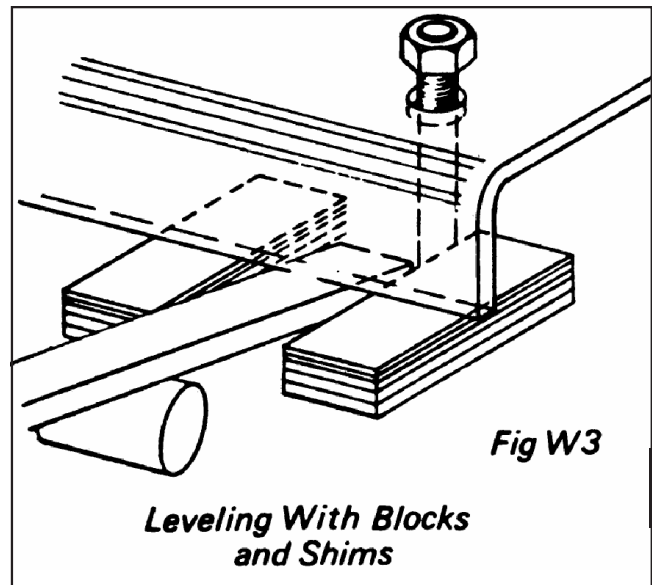

## PUMP-DRIVER ALIGNMENT

 **Alignment procedures must be followed to prevent unintended contact of rotating parts. Follow coupling manufacturer's installation and operation procedures.**

### SHAFT ALIGNMENT OF HORIZONTAL PUMP AND DRIVER

Pumps and drivers that are received from the factory with both machines mounted on a common subbase were accurately aligned before shipment. Because all subbases are, to some extent, flexible, factory alignment may be altered during shipment and handling. After the subbase has been leveled, grouted, and secured, check the alignment. Alignment should be rechecked after the pump is fully installed and before startup. Refer to the *Alignment Procedure*.

Disconnect coupling halves before proceeding with alignment. Check for angular and parallel alignment in the *Alignment Procedure*. The faces and outside diameters of the coupling halves must be square and concentric with the bores. If this condition does not exist, the *Alternate Method of Alignment* is recommended.

Subbase mounted horizontal pumps may be shipped with or without drivers and gears. Be sure pump and drivers are uncoupled before installation. Level by shimming beside each anchor bolt and grout as described in *Installing Pump on Foundation*.

### ALIGNMENT PROCEDURE

A check for angular alignment is made by inserting the taper gauge or feelers at four points between the coupling faces and comparing the distance between the faces at four points

spaced around the coupling. The unit will be in angular alignment when the measurements show that the coupling faces are the same distance apart at all points (Fig. W7).

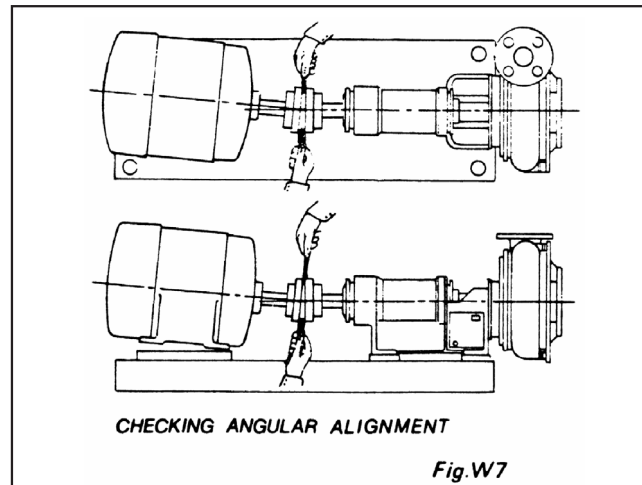

A check for parallel alignment is made by placing a straight edge across both coupling rims at the top, bottom, and at both sides. The unit will be in parallel alignment when the straight edge rests evenly on the coupling rim at all positions. Allowance may be necessary for temperature changes and for coupling halves that are not of the same outside diameter.

**NOTE:** Care must be taken to have the straight edge parallel to the axis of the shafts (Fig. W8).

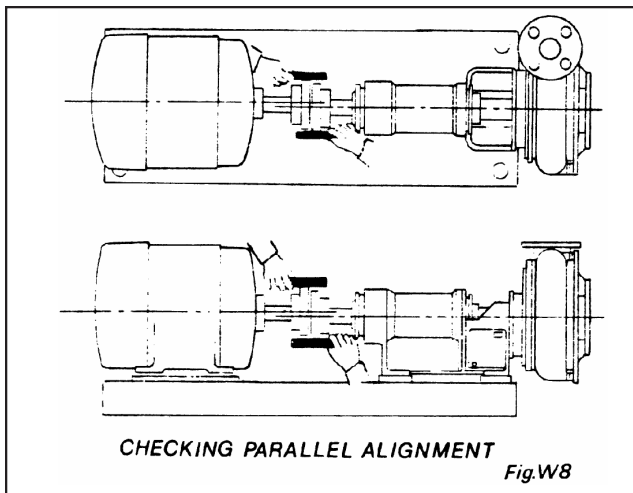

Angular and parallel misalignment are corrected by means of shims under the motor mounting feet. After each change, it is necessary to recheck the alignment of the coupling halves. Adjustment in one direction may disturb adjustments already made in another direction. It should not be necessary to adjust the shims under the pump. The permissible amount of misalignment will vary with the type of pump and driver. The manufacturer's recommendations should be obtained and followed.

When the driver is to be mounted on the subbase in the field, it is necessary to place the subbase with pump on the foundation to level the pump shaft, to check the coupling faces, the suction and discharge flanges for horizontal or vertical position, and to make any necessary corrective adjustments.

When the units are lined up cold, it may be necessary to make an allowance for the vertical rise of the driver and/or pump caused by heating. Goulds Pumps recommendations should be obtained and followed.

## ALTERNATE METHOD OF ALIGNMENT

An approved method for putting the coupling halves in final accurate alignment is by the use of a dial indicator. Check alignment by straight edge, taper gauge or feelers as accurately as possible by the procedure indicated above.

Bolt the indicator to the pump half of the coupling, with the indicator button resting on the other half coupling periphery, set the dial to zero, and chalk mark the coupling half at the point where the button rests. For any check, top, bottom, or sides, rotate both shafts by the same amount; i.e., all readings on the dial must be made with button on the chalk mark.

The readings will indicate whether the driver has to be raised or lowered or moved to either side. After each movement, check to see that coupling faces remain parallel to one another.

With this method, accurate alignment of shaft centers can be obtained even where faces or outside diameters of the coupling halves are not square or concentric with the bores, provided all measurements for angular alignment are made between the same two points on the faces, and all measurements for parallel alignment are made between the same two points on the outside diameters. Gross deviations in squareness or concentricity, however, may cause problems due to coupling unbalance or abnormal coupling wear and may need to be corrected for reasons other than accomplishment of shaft alignment.

## ALIGNMENT OF GEAR TYPE COUPLINGS

Gear type couplings are aligned in the same manner as outlined above. However, the coupling covers must be moved back out of the way and measurements made on the coupling hubs as shown on Fig. W9.

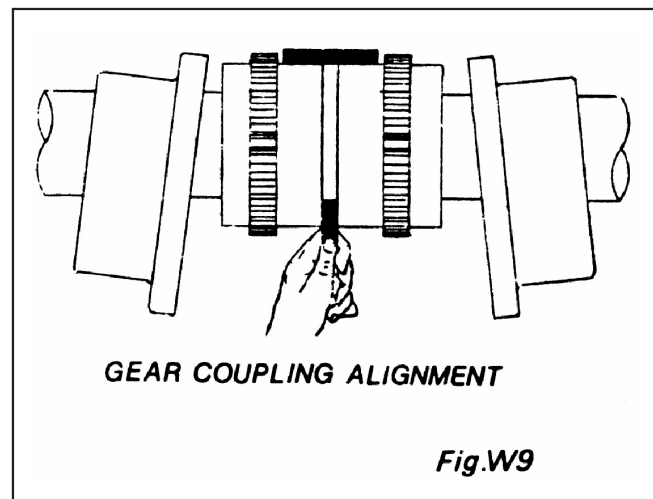

## FACTORS THAT MAY DISTURB ALIGNMENT

The unit should be checked periodically for alignment. If the unit does not stay in line after being properly installed, the following are possible causes:

- Settling, seasoning or spring of the foundation.
- Wear of the bearings.
- Pipe strains distorting or shifting the machine.
- Springing of the baseplate by heat from an adjacent steam pipe or from a steam turbine.
- Shifting of the building structure due to variable loading or other causes.
- Loose nuts or bolts on the pump or driver assembly.

# OPERATION

PREPARATION FOR START-UP . . . . .	17
PUMP START-UP . . . . .	18
LOCATING PROBLEMS. . . . .	20

## PREPARATION FOR START-UP

### STUFFING BOXES

In the conventional stuffing box, mechanical seals and packing seal between the stationary and rotating components of the pump. Generally, a clear liquid such as water is forced through the stuffing box to lubricate the sealing elements. The lubricating liquid pressure must exceed the pressure of the pumpage at the stuffing box. For end suction pumps, lubricating liquid pressure should be 10-15 PSIG higher than the discharge pressure. For side and double suction pumps, lubricating liquid pressure should be 10-15 PSIG higher than the suction pressure.

**NOTE:** To determine suction or discharge pressure, use gauge pressure only.

The piping supplying the lubrication liquid should be fitted tightly to prevent air from entering. On suction lifts, a small quantity of air entering the pump at this point may result in loss of suction.

Lubrication liquid pressure is controlled by a valve on the outlet piping. Since the liquid leaking from the stuffing box should be clear, control of the packing lubricant will vary with the condition of the packing. Increase pressure within the stuffing box by closing outlet valve. Adjustments should be slow and consistent with the run-in procedure for new packing.

The lubricating liquid must be clean, free of grit and acid. Shaft sleeve scoring, packing destruction, and mechanical seal face damage will result from contaminated lubricant.

### PACKING

 Packed stuffing boxes are not allowed in an ATEX classified environment.

Original equipment packing is a suitable grade for the service intended. To replace original packing, contact your local Goulds representative.

Refer to Bill of Material and Assembly Drawing for specific packing size and configuration.

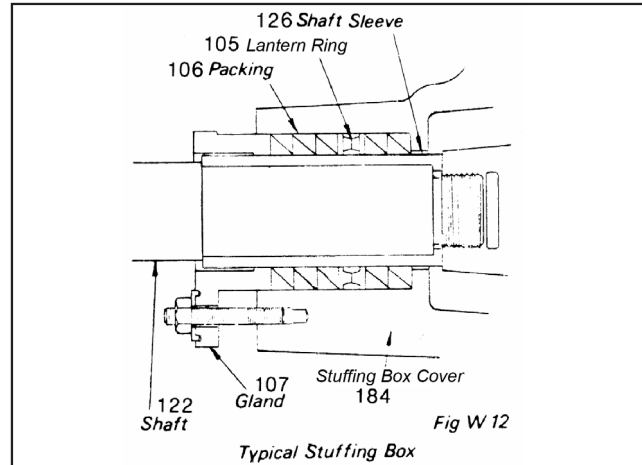

### PACKING PROCEDURE

1. Stuffing box and shaft sleeve must be clean and free of grit.
2. Form packing over shaft or mandrel of same diameter. Carefully cut to packing length. Discard rings cut too short.
3. Pre-form each ring by coiling 1-½ turns.
4. To install packing rings, do not pull straight. Expand the coil as a coil spring. (See Fig. W13.)

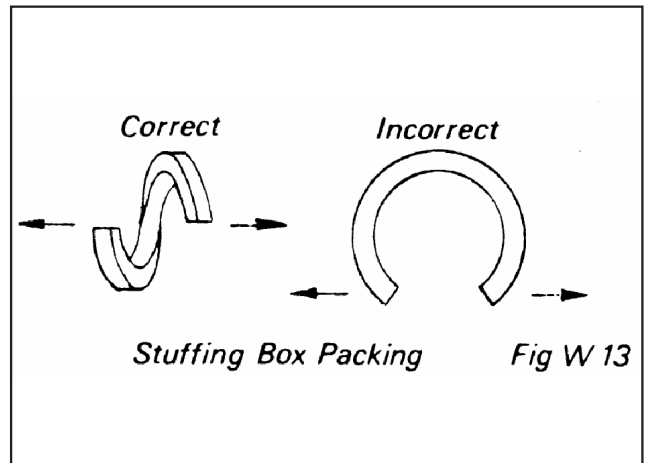

5. Expand first coil as shown and insert into stuffing box. Tamp packing to stuffing box shoulder firmly with the gland. Note where the cut is positioned.
6. Install second and third coils as required by assembly drawing, staggering the cut 90°-120°.
7. Insert seal cage (lantern ring) into stuffing box, carefully noting its proper position on assembly drawing. Failure to properly locate seal cage will result in insufficient packing lubrication. Packing and shaft sleeve damage will occur.
8. After packing and seal cage are properly installed, insert gland into stuffing box. Tighten gland nuts finger-tight only. Shaft should turn freely.

**NOTE: Do not over tighten gland nuts. Packing may set permanently and require removal. Over tightened packing causes excessive friction between packing and sleeve, and will result in damaged components. A noticeable temperature increase in stuffing box would indicate insufficient lubrication.**

9. Follow pump start-up procedure. Turn on stuffing box lubricating liquid and start pump.
10. A significant amount of lubricating liquid should leak from gland side of stuffing box. Operate pump for at least 15 minutes before tightening gland nuts. Make small, even gland nut adjustments to reduce leakage. Allow adequate run-in time between adjustments. Acceptable leakage is 30-50 drops per minute.
11. Periodic maintenance is absolutely required for all packed pumps.

Normal shaft run-out should be under .005" to avoid pounding of stuffing box packing. With excessive shaft run-out, shaft straightening or replacement is necessary.

## MECHANICAL SEALS



**The mechanical seal used in an ATEX classified environment must be properly certified.**



**The mechanical seal must have an appropriate seal flush system. Failure to do so will result in excess heat generation and seal failure.**

Most mechanical seals are installed and adjusted at the factory. Due to size and design, some installed mechanical seals are supplied with shipping retainers. Shipping retainers hold the sealing faces apart to avoid damage during transport. Shipping retainers must be removed before shaft is to be rotated. Pumps with retained seal faces will be specially marked and instructions from the seal manufacturer for retainer removal will be provided. Mechanical seals have a stationary and a rotating sealing face. Commonly, these sealing rings are of carbon and ceramic material, brittle in nature, and easily damaged. As the sealing rings seat with the operation of the pump, a compatible wear pattern develops between the mating surfaces. To disassemble the mechanical seal after the wear pattern is established would necessitate the replacement of the rotating and stationary sealing elements. Do not replace only one component.

To insure the life and sealing characteristics of the mechanical seal, lubricating liquid must be circulated through the stuffing box. Clear, grit free liquid is necessary.

Special seal information and replacement seal elements should be provided by the seal manufacturer. Goulds strongly recommends the stocking of replacement sealing elements.



### CAUTION

**Do not make shaft adjustments on mechanical seal installations without consulting seal instructions and pump assembly drawing.**

## PUMP START-UP



**Service temperature in an ATEX classified environment is limited to the area classification specified on the ATEX tag affixed to the pump (reference Table 1 in the ATEX identification section).**



**The coupling used in an ATEX classified environment must be properly certified.**



**The coupling guard used in an ATEX classified environment must be constructed from a non-sparking material.**

### START-UP PRECAUTIONS

1. All equipment and personal safety related devices and controls must be installed and operating properly.
2. To prevent premature pump failure at initial start up due to dirt or debris in the pipe system, ensure the system has been adequately cleaned and flushed.

3. Variable speed drivers should be brought to rated speed as quickly as possible
4. Variable speed drivers should not be adjusted or checked for speed governor or over speed trip settings while coupled to the pump at initial start up. If settings have not been verified, uncouple the unit and refer to driver manufacturer's instructions for assistance.

Pumpage temperatures in excess of 200°F will require warmup of pump prior to operation. Circulate a small amount of pumpage through the pump until the casing temperature is within 100°F of the pumpage temperature and evenly heated.



### CAUTION

*When starting the pump, immediately observe pressure gauges. If discharge pressure is not quickly attained, stop driver, reprime and attempt to restart.*

### BEARING LUBRICATION

Bearings must have adequate lubrication. Engage external lubrication system. Consult "BEARING SECTION" of these instructions for specific information.

### SHAFT ROTATION

The pump shaft must turn without any binding or rubbing. By manually turning the rotating element, only the uniform frictional drag of the bearings and the stuffing box should be sensed.



### CAUTION

*Serious damage may result if the pump is run in the wrong direction*

### CORRECT ROTATION OF THE DRIVER

The direction of rotation of the driver must be checked before it can be coupled with the pump. The direction of rotation of the pump is indicated in a prominent location. For pumps with impellers threaded on the shaft, reverse rotation would back the shaft from the impeller thread. Considerable damage may occur.



*Lock out driver power to prevent electric shock, accidental start-up and physical injury.*



*When installing in a potentially explosive environment, ensure that the motor is properly certified.*

### LUBRICATING LINES TO STUFFING BOX

Lubricating liquid must be flowing to the stuffing box before the pump is started. Both mechanical seals and packing require lubrication for continuous service.

### PRIMING

The pump must be completely primed before operation.



*Pumps must be fully primed at all times during operation.*

### WATER HAMMER

Water hammer is a high pressure surge within a closed pipe system, created by rapid change in the flow rate. Changes in the flow rate occur when there are sudden changes in pump speed. The most common cause is the sudden opening or closing of a valve or flow control device. Extensive damage to the pump and pipeline is a result of water hammer.

### FREEZING

If the pump is exposed to below freezing temperatures, the liquid should be drained during idle periods.



# LOCATING PROBLEMS

## CONDITIONS LEADING TO INSUFFICIENT OR NO DISCHARGE

- Insufficient speed.
- Excessive discharge head
- Insufficient NPSH.
- Worn pump components
- Incorrect direction of rotation
- Incomplete pump priming
- Impeller or discharge pipe clogged
- Pumpage viscosity too high

## CONDITIONS LEADING TO EXCESSIVE POWER CONSUMPTION

- Excessive speed.
- Pump operating at high horsepower area of the pump curve (off design point)
- Mechanical binding or rubbing of rotating element.
- Pumpage specific gravity and/or viscosity too high

### CAUTION

*Always vary capacity with regulating valve in the discharge line. NEVER throttle flow from the suction side*

### CAUTION

*Driver may overload if the pumpage specific gravity (density) is greater than originally assumed, or the rated flow rate is exceeded*

### CAUTION

*Always operate the pump at or near the rated conditions to prevent damage resulting from cavitation or recirculation*

### WARNING

*Do not operate pump below minimum rated flows or with suction and/or discharge valve closed. These conditions may create an explosive hazard due to vaporization of pumpage and can quickly lead to pump failure and physical injury.*

### CAUTION

#### *Damage occurs from:*

- Increased vibration levels – affects bearings, stuffing box or seal chamber and mechanical seal
- Increased radial loads – Stresses on shaft and bearings
- Heat build up–Vaporization causing rotating parts to score or seize
- Cavitation–Damage to internal surfaces of pump

### CAUTION

*Observe pump for vibration levels, bearing temperature and excessive noise. If normal levels are exceeded, shut down and resolve.*

### WARNING!

*This unit must never be used without prior installation of the safety guards for rotating parts as prescribed by O.S.H.A.*

*Operation of this pump with both suction and discharge valves closed for even brief periods of time is an unacceptable and dangerous practice. it can rapidly lead to a violent pump failure.*

### WARNING!

*Inspection intervals should be shortened appropriately if the pumpage is abrasive and/or corrosive, or if the environment is classified as potentially explosive.*

### WARNING!

*DO NOT apply heat to hub or nose of threaded impeller. There is a danger of explosion.*

# PREVENTIVE MAINTENANCE

**GENERAL COMMENTS . . . . . 21**  
**MAINTENANCE SCHEDULE . . . . . 21**  
**LIQUID END . . . . . 22**  
**POWER END . . . . . 23**  
**IMPELLER CLEARANCES . . . . . 23**  
**MAINTENANCE OF BEARINGS . . . . . 24**

## GENERAL COMMENTS

A routine maintenance program can extend the life of your pump. Well maintained equipment will last longer and require fewer repairs. It is recommended maintenance records be kept – this will help pinpoint potential causes of problems.

The Preventive Maintenance section must be adhered to in order to keep the applicable ATEX classification of the equipment. Failure to follow these procedures will void the ATEX classification for the equipment.

## MAINTENANCE SCHEDULE

### Routine Maintenance

- Bearing lubrication
- Seal Monitoring
- Vibration analysis
- Discharge pressure
- Temperature monitoring

### Quarterly Inspections

- Check foundation and hold-down bolts for tightness.
- If pump has been left idle, check packing. Replace if required.
- Oil should be changed at least every 3 months or more often if there are any adverse atmospheric conditions or other conditions which might contaminate or break down the oil.

### Routine Inspections

- Check level and condition of oil through sight glass on bearing housing.
- Check for unusual noise, vibration and bearing temperatures.
- Inspect pump and piping for leaks.
- Check stuffing box leakage.
- Packing: Excessive leakage requires adjustment or possible packing replacement.
- Mechanical Seal: Should be no leakage.

# LIQUID END

## TO DISASSEMBLE THE LIQUID END

1. Drain pumpage from pump and pipe line. Disconnect auxiliary lubrication lines, suction and discharge pipe line connections. Uncouple pump from driver.



### WARNING

*When handling hazardous and/or toxic fluids, proper personal protective equipment should be worn. If pump is being drained, precautions must be taken to prevent physical injury. Pumpage must be handled and disposed of in conformance with applicable environment regulations.*

2. Remove cap screws or bolts which fasten suction disc (182) to casing (100).
3. Remove suction disc (182) and suction disc liner (100B) from casing fit.
4. Impeller (101) is threaded onto shaft (122). Remove impeller by restraining coupling end of shaft and turning impeller in the operating direction of rotation. Do not apply heat.

*NOTE: If impeller is frozen on shaft, restrain the impeller, attach a spanner wrench to coupling end of shaft, and give the wrench a sharp blow.*



### WARNING!

*DO NOT apply heat to hub or nose of threaded impeller. There is a danger of explosion.*

5. Remove cap screws or bolts which fasten casing (100) to hub disc (184). Slide casing from hub disc fit.
6. Disassemble gland (107) from stuffing box.
7. Remove bolts which fasten hub disc (184) and bearing frame (228). Carefully pull hub disc from shaft sleeve (126). Packing (106) and seal cage (105) may be left in stuffing box during disassembly of hub disc and removed hub disc is separated from bearing assembly.
8. Pull or drive shaft sleeve (126) from shaft (100) if replacement is necessary.

## TO ASSEMBLE THE LIQUID END

1. Shaft (122) and shaft sleeve (126) must be clean and free of burrs. Install sleeve (126) on shaft.
2. Carefully guide hub disc (184) stuffing box over impeller end of shaft. Secure hub disc (184) to bearing frame (228) with bolts (370C).

3. Position casing (100) with gasket into hub disc (184) fit. Be sure discharge is in proper orientation. Fasten casing to hub disc with cap screws (370J).
4. Install impeller (101) with gasket onto shaft (100). Drawing impeller tight on shaft threads firmly secures shaft sleeve. Seal sleeve to impeller with RTV silicone.
5. Place suction disc liner (100B) into casing fit. With O-ring (412F) in position on liner O.D., install suction disc (182). Fasten suction disc to casing with cap screws (370E).
6. Set impeller clearance according to section *Impeller Clearance* in the bearing section of this manual.



*Improper impeller adjustment could cause contact between the rotating and stationary parts, resulting in a spark and heat generation.*



*The impeller clearance setting procedure must be followed. Improperly setting the clearance or not following any of the proper procedures can result in sparks, unexpected heat generation and equipment damage.*

7. Install packing (106), seal cage (105) and gland (107). Refer to assembly drawing for proper packing sequence and to section *Stuffing Boxes* in the General Instructions.
8. Install pump half of coupling or sheave. Realign pump and driver. Connect pump section and discharge to pipe line. Connect auxiliary lubrication lines.
9. Start-up instructions....Refer to General Instructions





# POWER END

## “J” TYPE BEARING

The “J” type bearing assembly uses medium-heavy ball bearings. On the small size “J” bearings, double row ball bearings are used for combined loading. The larger sizes utilize separate radial and thrust ball bearings. Adjustment of nose clearance can be easily accomplished without bearing disassembly.

## IMPELLER CLEARANCES

 **Improper impeller adjustment could cause contact between the rotating and stationary parts, resulting in a spark and heat generation.**

 **The impeller clearance setting procedure must be followed. Improperly setting the clearance or not following any of the proper procedures can result in sparks, unexpected heat generation and equipment damage.**

To maintain maximum operating efficiency, a uniform 1/64" - 1/32" clearance between the parallel surfaces of suction disc liner (100B) and the nose of the impeller (101) is necessary. The clearance is adjusted by moving shaft (122) toward or away from suction disc liner (100B). There are adjusting lugs cast on bearing frame (228) and thrust bearing housing (134A). Studs (356A) threaded into thrust bearing housing lugs fit through the slots of bearing frame lugs. Jam nuts on studs, located on both sides of the frame lugs, are used to adjust and fasten the thrust bearing housing relative to the bearing frame.

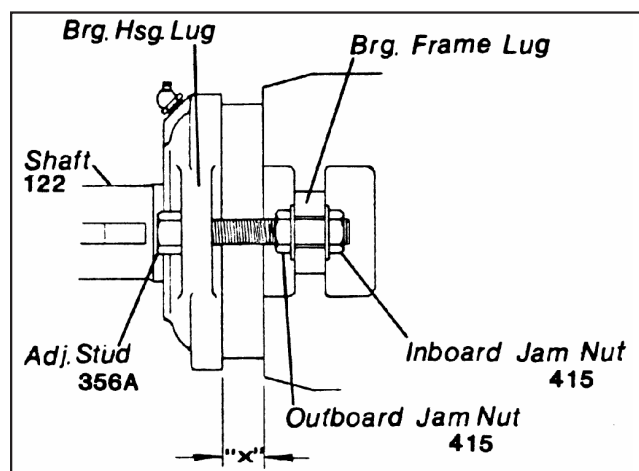

## METHODS TO DETERMINE IMPELLER NOSE CLEARANCE

### During Installation Or Repair

With a feeler gauge, measure the gap between the nose of the impeller and the casing liner on the suction side.

### During Normal Service

Move impeller toward suction side of casing liner until parallel surfaces slightly rub. Measure “X” dimension and add the recommended impeller nose clearance. Adjust dimension “X” per “Impeller Clearance Adjustment Procedure.”

### Impeller Clearance Adjustment Procedure

1. Turn stud jam nuts at the bearing frame lugs to drive the shaft assembly in the desired direction. Moving shaft (122) toward suction side casing liner will decrease the clearance
2. To decrease impeller clearance, loosen outboard jam nut and drive the shaft assembly by turning the inboard jam nut.
3. When desired clearance is reached, tighten outboard jam nut securely. Check clearance after tightening.
4. To increase impeller clearance, loosen inboard jam nut and drive the shaft assembly by turning the outboard jam nut.



## CAUTION

**Jam nuts on both sides of bearing frame lugs must be secure. Normal impeller thrust will tend to decrease the impeller clearance. Impeller rubbing will result from insufficient jam nut tightening.**

### Conditions Requiring Adjustments

1. Overheated thrust bearings may develop from uneven adjustment of jam nuts. Check lubrication.
2. Noise, vibration and wear may result from the impeller rubbing on the suction or hub side casing liners. Adjust impeller clearance.

3. Poor performance and wear may result from excessive impeller clearance at the suction side casing liner.

**NOTE: Lubricate adjusting studs (356A) for easy maintenance.**

## MAINTENANCE OF BEARINGS

### BEARING LUBRICATION AND CARE

 **Bearings must be lubricated properly in order to prevent excess heat generation, sparks, and premature failure.**

 **The Preventive Maintenance section must be adhered to in order to keep the applicable ATEX classification of the equipment. Failure to follow these procedures will void the ATEX classification for the equipment.**

 **Throughout this section on bearing lubrication, different pumpage temperatures are listed. If the equipment is ATEX certified and the listed temperature exceeds the applicable value shown in Table 1 under ATEX identification, then that temperature is not valid. Should this situation occur, please consult with your ITT/Goulds representative.**



### CAUTION

 **Operation of the unit without proper lubrication will cause bearing failure, and pump seizure.**

### OIL LUBRICATION

When the pump is furnished with oil lubrication, a good grade of oil should be used to insure long bearing life.

**NOTE: Pumps furnished for oil lubrication are shipped without oil. Add oil until the level is up to the oil level line before the unit is started.**

If too much oil is added, there will be excessive heat generated in the bearings and there may be leakage from the shaft seals. We recommend a commercial oil such as Mobil D.T.E. oil, B.B., Tellus 41 or equal. However, a good grade of #30 or #40 weight is satisfactory for normal temperatures.

For best results, the weight of the oil lubricant should be adjusted for the normal operating temperature as follows:

To 150°F – SAE 20  
To 160°F – SAE 30  
To 175°F – SAE 40  
To 200°F – SAE 50

### GREASE LUBRICATION

When the pump is furnished for grease lubrication, the pump will be shipped with the bearings hand-packed with Mobilux #2 grease, unless otherwise specified by the customer. Other suitable greases are Humble Lidok #2, Texaco Regal Starfak #2, and Shell Alvania #2. If another brand is desired, it should be checked with the supplier to determine if it is equivalent to the above.

#### Installing A Bearing

The bearings have sufficient grease for at least 24 hours of operation after start-up. The bearings will run hotter than normal for the first few hours until the grease is worked out of the ball path and the bearings have “run in”. Adding more grease during this period may increase the bearing temperature.

After the first regreasing, a small amount of grease should be added at each fitting every 500 hours of operation.

#### Normal Bearing Temperature

Long bearing life is quite dependent on careful handling of a bearing when it is out of the housing and during the installation procedure. Dirt and rough handling are prime enemies of precision bearings. Bearings should be pressed, not “hammered” into place. If heat is used to facilitate the installation, a hot oil bath is the best method. Bearings for grease lubrication should be hand-packed with grease to insure adequate lubrication at start-up.

**NOTE: The shaft seals above each bearing should be oiled with a few drops of #30 oil before the pump is started to insure lubrication of the seal lip.**

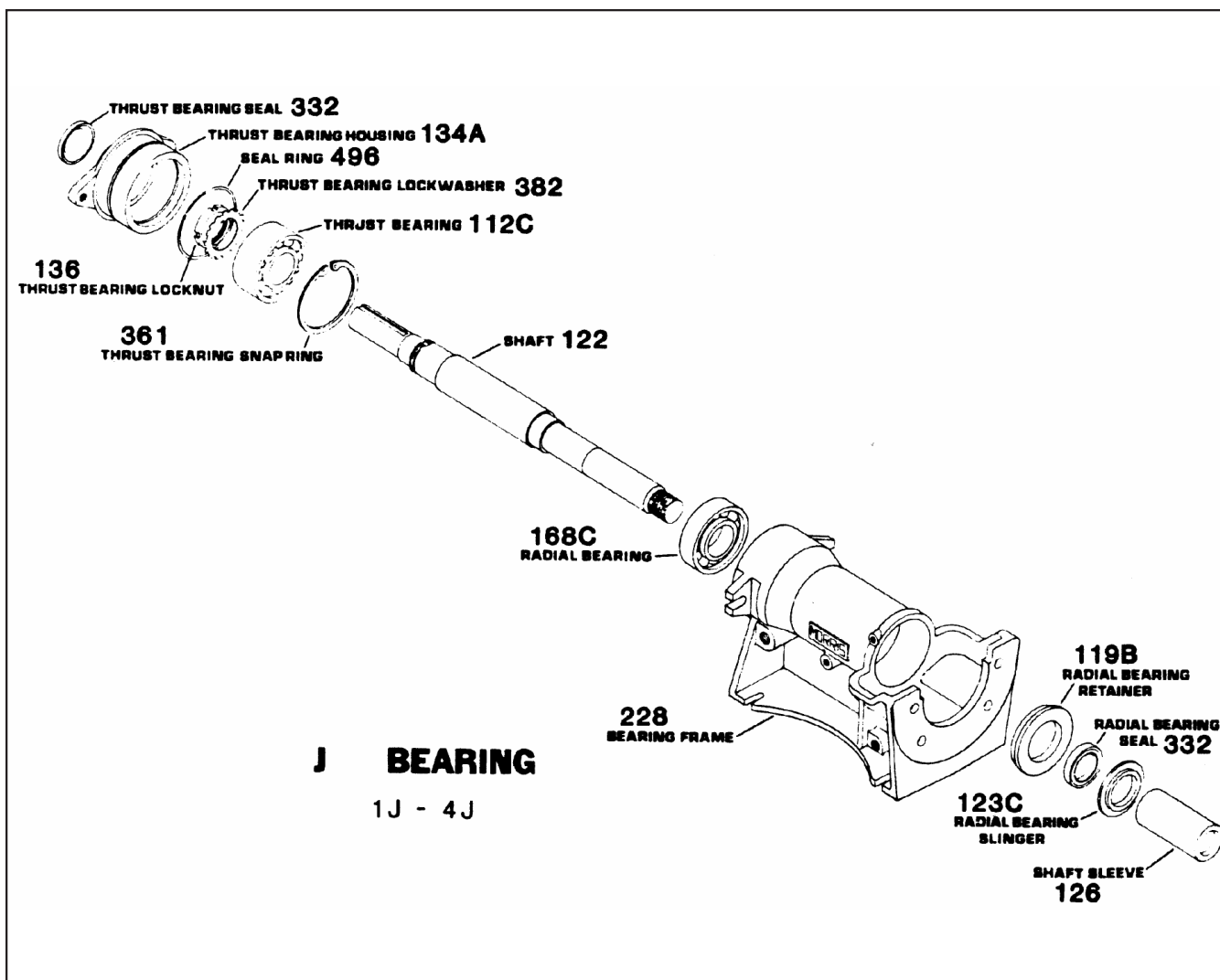

The running temperature for a bearing assembly depends on many factors such as speed, bearing loads, ambient air temperature, and condition of bearings. Temperatures higher than the human hand can tolerate are very satisfactory for good bearing operation and should not cause alarm.

For a given speed and loading, the bearing housing temperature will stabilize at some temperature, usually below 200° F, which will be the normal temperature for that installation. Higher temperatures than this normal temperature, without any change in speed or loading, can mean a lubrication difficulty or the approach of a bearing failure.

## TO DISASSEMBLE THE “J” BEARING

For the purpose of these instructions, assume the JC liquid end has been disassembled, including suction disc (182), suction disc liner (100B), impeller (101), casing (100), hub disc (184), stuffing box components, and shaft sleeve (126).

1. Pull pump coupling half or sheave from drive end of shaft.
  2. Remove radial bearing slinger (123C) from shaft.
  3. Remove jam nuts from adjusting studs (356A) which fasten bearing frame (228) and thrust bearing housing (134A). Carefully pull the shaft (122), bearings, and thrust bearing housing (134A) from the drive end of bearing frame (228). Support both ends of the shaft assembly to prevent seal and bearing damage.
  4. Detach thrust bearing snap ring (361) from thrust bearing housing (134A). Slide housing over thrust bearing.
- NOTE:** See illustrations for specific thrust bearing configuration.
5. Remove thrust bearing locknut (136) and lockwasher (382).
  6. Press or pull radial bearing (168C) from shaft (122). Apply pulling force to inside bearing race only.

7. Press or pull thrust bearing arrangement from shaft (122). For double row ball thrust bearing (112C), apply pulling force to inside race only. For two-bearing thrust arrangement, apply pulling force to inside race of thrust bearing (112D). The thrust bearing (112D), thrust bearing collar (237), and radial bearing (112C) will be removed.
8. Do not remove radial bearing retainer (119B) from bearing frame (228). A factory press fit insures a permanent installation.

## TO ASSEMBLE THE “J” BEARING

1. The shaft (122), thrust bearing housing (134A) and bearings must be clean and free of burrs.
2. To assemble thrust bearing arrangement:
  - a. Double row ball thrust bearing: (1J-4J)
    - 1) Heat thrust bearing (112C) in 180° F oil bath.
    - 2) Slide thrust bearing (112C) onto shaft (122) firmly against shaft shoulder.
    - 3) Install lockwasher (382) and locknut (136) before bearing cools. When bearing cools to room temperature, retighten locknut and secure lockwasher tang.
  - b. Separate thrust (112C) and radial (112D) bearings on thrust end (5J):
    - 1) Heat thrust bearing (112D) in 180° F oil bath and install on shaft (122) firmly against shaft shoulder.
    - 2) Heat thrust bearing collar (237) in oil bath and install shaft against inner thrust bearing inner race.
    - 3) Heat radial bearing (112C) in oil bath and install on shaft with inner race against thrust collar (237).
    - 4) Install lockwasher (382) and locknut (136) before bearings cool. When bearings cool to room temperature, retighten locknut and secure with lockwasher tang.
3. To install thrust bearing housing (134A):
  - a. Double row ball thrust bearing:
    - 1) Lubricate seal (332) and O-ring (496) on thrust bearing housing (134A).
    - 2) Carefully slide housing (134A) onto shaft (122) over thrust bearing.
    - 3) Secure housing (134A) with thrust bearing snap ring (361).
  - b. Separate thrust (112D) and radial (112C) bearings on thrust end:
    - 1) Lubricate seal (332) and O-ring (496) on thrust bearing housing.
    - 2) Carefully slide housing (134A) onto shaft and bearings until housing shoulder bottoms on outer race of radial bearing (112C).
4. Heat radial bearing (168C) in 180° F oil bath. Slide radial bearing onto shaft (122) firmly against shaft shoulder. Allow bearing to cool to room temperature before further assembly.
5. Lubricate seal 332 in radial bearing retainer (119B). Carefully insert the shaft/bearing assembly into the bearing frame (228) from the drive end. Guide the threaded end of the shaft through seal (332) in retainer (119B). As the thrust bearing housing (134A) enters the bearing frame bore, align adjusting lugs on the frame and housing.
6. Loosely install adjusting studs (356A) in adjusting lugs. Do not tighten.
7. Install radial bearing slinger (123C).
- 3) Install thrust bearing snap ring (361) into ring groove of housing.
- 4) With feeler gauge, measure clearance between snap ring (361) and outer race of thrust bearing (112D). The clearance should be .004 - .010 at “G” gap.
- 5) From the feeler gauge measurement, subtract .007”. The resulting dimension is the thickness of shims (331) at “S” gap.
- 6) Remove snap ring. Pull housing (134A) and install calculated shim pack (331) against housing shoulder. Reinstall housing and snap ring.

**NOTE: Radial retainer permanently pressed into bearing frame (228) at factory.**

# SPARE PARTS

**ORDERING SPARE PARTS . . . . . 27**  
**PARTS LIST . . . . . 28**  
**JC SECTIONAL VIEW . . . . . 29**

## ORDERING SPARE PARTS

To insure against possible long and costly downtime periods, especially on critical services, it is advisable to have spare parts on hand.

Parts orders will be handled most promptly if the following directions are followed.

1. Include pump model and size and its serial number as shown on the nameplate.
2. For each part required, include the name and part number.
3. State the quantity required for each part.
4. Provide complete shipping instructions.

### RECOMMENDED SPARES

The following are recommended spare parts.

- 1 Suction Liner (100B)
- 1 Impeller (101)
- 1 Lantern Ring (105)
- 5 Packing Rings (106)
- 1 Thrust Bearing (112C)
- 1 Shaft Sleeve (126)
- 1 Radial Bearing (168C)
- 1 Parts Kit, see chart

<b>Parts Kit Chart</b>	
<b>Pump Size</b>	<b>Kit Number</b>
1×1.5-8, 1.5×2-8, 2×3-8	520101
1×1.5-11, 1.5×2-11, 2×3-11	520102
1.5×2-14, 2×3-14	520103
3×4-11	520104
3×4-14, 4×6-14	520105
6×6-14 HS	520106
6×6-14 LS	520107
8×10-18	520108
10×12-22	520109

Parts Kits include thrust bearing locknut, lockwasher and snap ring, grease seals, and required gaskets and/or O-rings.

# PARTS LIST

<b>TYPICAL</b>			
<b>Item</b>	<b>QTY/Pump</b>	<b>Part Name</b>	<b>Alternate Part Name</b>
100	1	Casing	
100B	1	Suction Liner	Suction Disc Liner
101	1(2)	Impeller	
105	1	Lantern Ring	Seal Cage
106	5	Packing Ring	
107	1	Gland	
112C	1	Thrust Bearing	
119B	1	End Cover	Bearing Retainer
122	1	Shaft	
123C		Deflector	Slinger
126	1(2)	Shaft Sleeve	
134A	1	Bearing Housing	
136	1	Locknut	
168C	1	Radial Bearing	
182	1	Suction Cover	Suction Disc
184	1	Stuffing Box Cover	Hub Disc
193B	2	Grease Fitting	
222	1	Set Screw	
228	1	Bearing Frame	
332	3	Grease Seal	
351	1(1)	Gasket	
353	2	Stud, Gland	
355	2	Hex Nut	
356A	2	Stud	
361	1	Snap Ring	
370C	4	H Cap Screw	
370E	8	H Cap Screw	
370J	8	H Cap Screw	
382	1	Lockwasher	
400	1	Key	
408	1	Pipe Plug	
412F	1	O-Ring	
415	4	Hex Jam Nut	
496	1	O-Ring	
528J	2	Washer, 353	
528K	8	Washer, 370E	
528L	8	Washer, 370j	
528P	4	Washer, 356A	

**NOTES:**

- (1) Buna-N O-Ring 496A replaces gasket 351 on sizes 6x6-14 and 8x10-18.
- (2) Sleeve 126 is sealed to impeller 101 with RTV silicone. All Sizes Except 10x12-22 Grease Lube Bearings.

# JC SECTIONAL VIEW

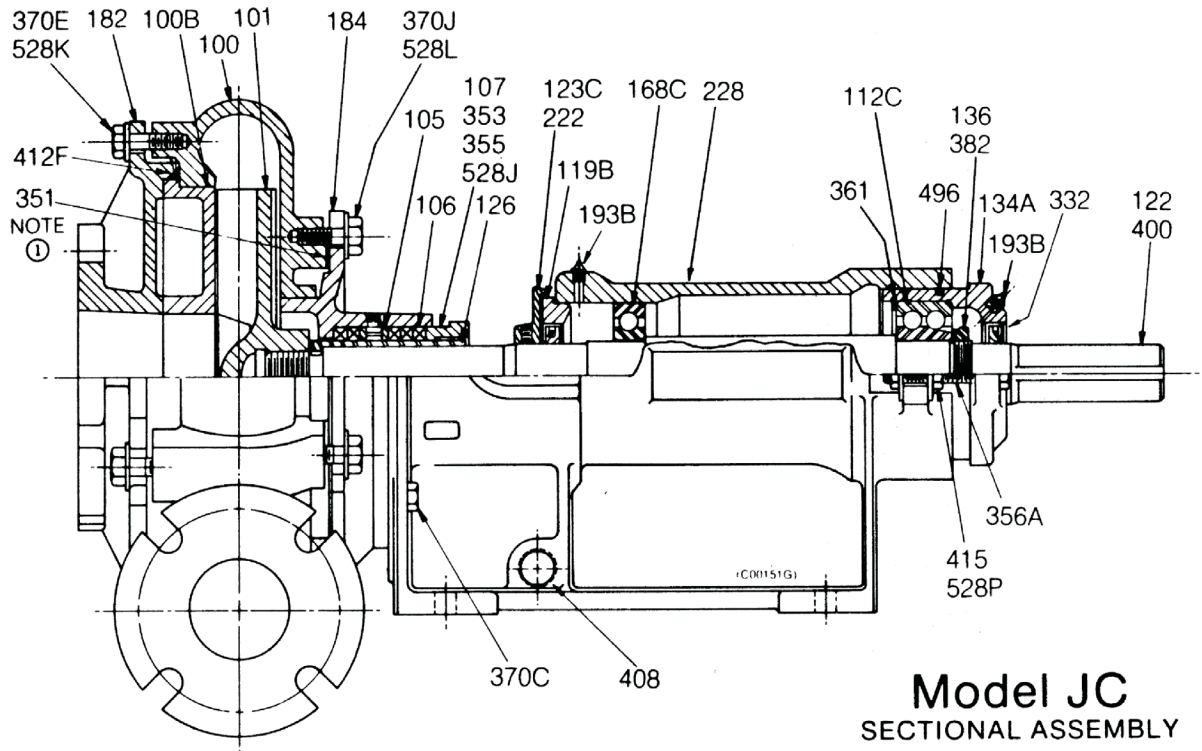

## Model JC SECTIONAL ASSEMBLY

ALL SIZES EXCEPT 10x12-22  
GREASE LUBE  
1J, 2J, 3J, 4J BEARINGS

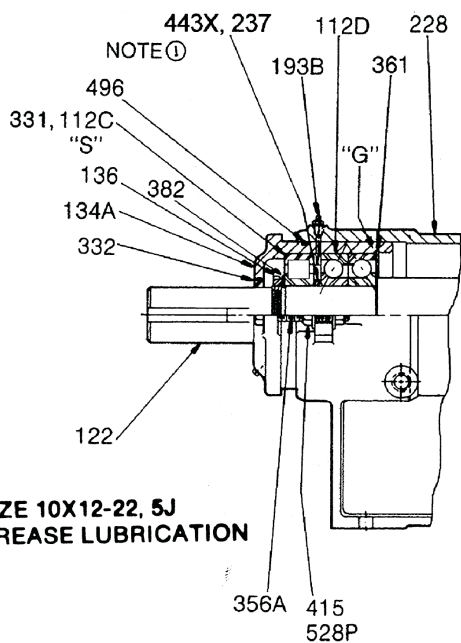

**SIZE 10X12-22, 5J  
GREASE LUBRICATION**

**This page intentionally left blank.**



# APPENDIX

## SPECIAL INSTRUCTIONS

### A) KAOLIN SERVICE -KJC PUMPS OPTIMUM IMPELLER RUNNING CLEARANCE

The optimum impeller running clearance is the minimum clearance that will not significantly increase the input horsepower from the shear rate induced drag at the suction disc liner. For most liquids or slurries, the optimum performance of the JC pump is achieved with the impeller almost rubbing against the suction disc. Increasing this clearance causes more internal leakage around the impeller vanes, which results in decreased performance.

When pumping kaolin clay, the decrease in pump head from the internal leakage can be more than offset by the decrease in horsepower such that the overall performance is increased. The optimum clearance is set by adjusting the pump, when it is running, using a discharge pressure gauge and ammeter to monitor the results.

During an adjustment to reduce the clearance, the clearance has become too small when the percentage increase in motor amperes exceeds the percentage increase in discharge pressure. The opposite is true when increasing the clearance. The adjustment can be made without a pressure gauge, but it will be less accurate though perhaps satisfactory for the application.

If the slurry percentage solids varies frequently, it may be more practical to adjust the clearance for the most difficult to pump slurry and not change it for the other concentration.

### B) EXPELLER

#### General



*Dynamic seals are not allowed in an ATEX classified environment.*

To meet the high demand for waterless sealing of stuffing boxes in slurry pumps, Ashland Operations/Goulds has added an expeller to the JC line. Using its basic bearing and wetted end configuration, the JC now incorporates a hub disc that has been enlarged to allow for the expeller option.

When operating at normal design conditions, the expeller reduces the pressure usually present in conventional end suction pump stuffing boxes to zero (0). Theoretically, the only need for a packed stuffing box in expeller pumps is to

seal the casing when the unit is shut-down or running at restricted flows.



#### WARNING!

**IMPORTANT: BEFORE PERFORMING ANY WORK, INSURE ELECTRICAL SUPPLY IS LOCKED OUT.**

#### Clearance Adjustment

The impeller clearance in the JC pump with optional expeller should be maintained at .015" from the face of the impeller (101) to the suction cover liner (100B). Adjust this clearance as often as necessary in order to maintain efficient pump performance.

**IMPORTANT: INSURE THAT THE IMPELLER IS TIGHTENED ON THE SHAFT PRIOR TO CLEARANCE ADJUSTMENT.**

#### To Disassemble The Liquid End

1. Remove bolts (370E) that fasten the suction cover 182 to the casing (100). Remove the O-Ring (412F) and the suction cover liner (100B). A gentle tap about the circumference of the liner may facilitate removal of the liner.
2. Remove the impeller (101) by securing it with a wooden or soft metal block and turn the shaft in the counter-clockwise direction facing the pump drive end from the motor. The reverse of this procedure is also possible. By securing the shaft, strike the impeller in the counter-clockwise direction using a lead or composite mallet.



#### WARNING!

**DO NOT APPLY HEAT TO THE IMPELLER.**

3. Remove the casing (100), expeller (262) and hub disc (expeller housing) (184) as one unit by only removing bolts (370C) that fasten this assembly to the bearing frame. Leave the packing and seal cage in the stuffing box to protect the sleeve and carefully slide the whole unit until it is clear of the shaft.
4. Remove bolts (370J) to expose the expeller for inspection.

#### To Assemble The Wetted End

1. Assemble the casing (100), expeller (262) and hub disc (184) using bolts (370J) prior to installation on the bearing frame.
2. Insert the shaft sleeve into the packed stuffing box so it engages with the recess in the expeller. This will act as a guide and center the expeller until the impeller can be installed.
3. Prior to sleeve installation on the shaft, apply a bead of silastic or silicon sealant on the expeller hub faces to seal the rotor assembly.
4. Carefully slide the whole assembly on to the shaft using the sleeve as a guide until the hub disc is aligned with the fit and bolt holes in the bearing frame.
5. Secure with bolts (370C).
6. Install the impeller by turning it in the clockwise direction taking care to tighten it against the expeller and shaft sleeve prior to clearance adjustment. Apply anti-seize or grease to threads of shaft to make future removal easier.
7. Replace the suction cover liner after applying a liberal amount of anti-seize compound or grease on the outer shoulder. This will also make removal easier in the future.
8. Install O-Ring (412F).0
9. Replace suction end cover (182) with bolts (370E). Only apply a moderate torque to tighten.
10. Check impeller clearance.

#### Lubrication

To lubricate the seals and purge the stuffing box, use a general purpose waterproof grease. Several shots of grease should be added to the stuffing box, as little as every three operating days or as much as every four operating hours, depending upon the severity of the pumpage abrasiveness. In addition, grease should be added prior to every tenth start-up.

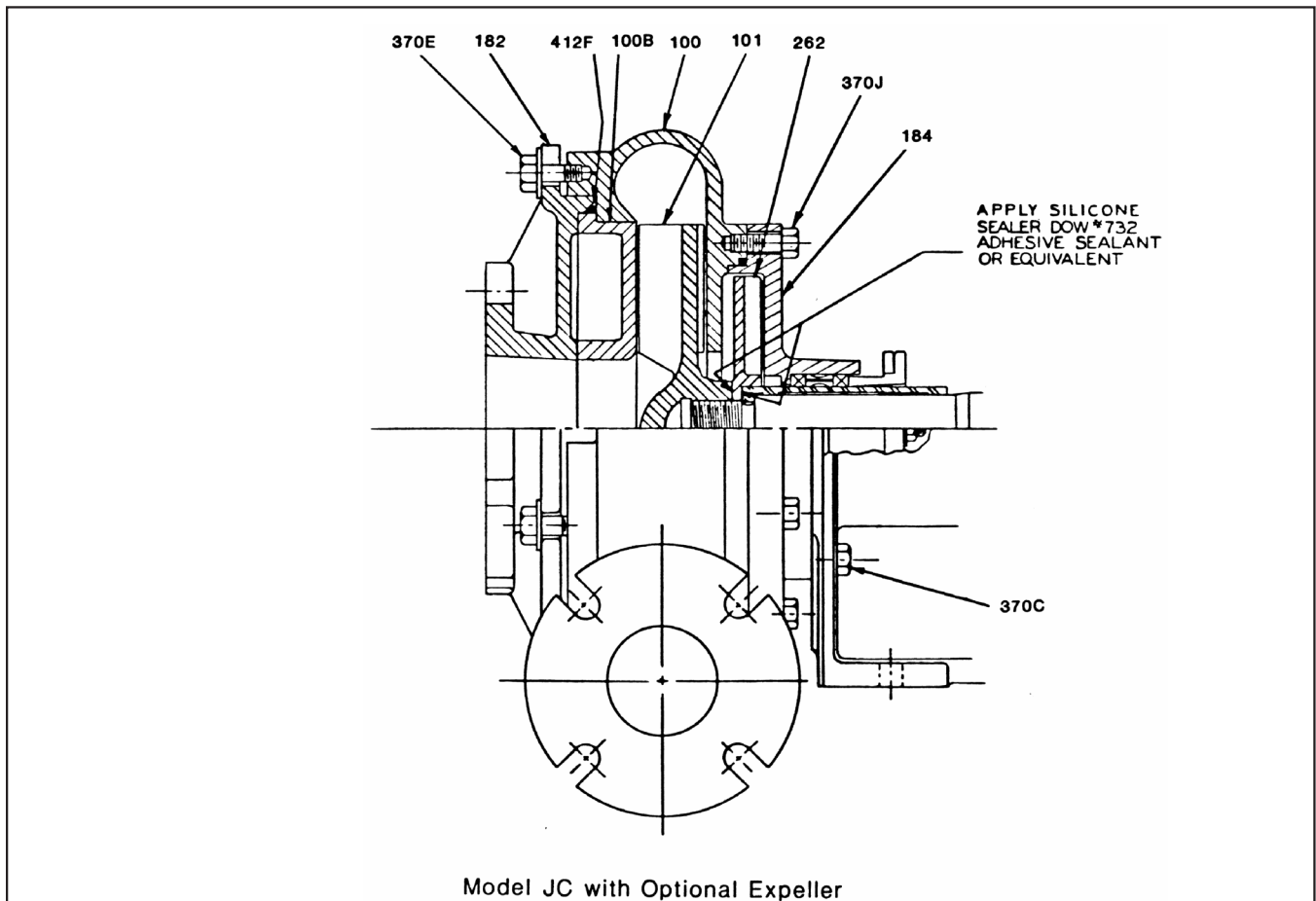



## HOW TO ORDER

When ordering parts call  
**1-800-446-8537**  
or your local Goulds Representative

## EMERGENCY SERVICE

Emergency parts service is available  
**24 hours/day, 365 days/year ...**  
Call **1-800-446-8537**

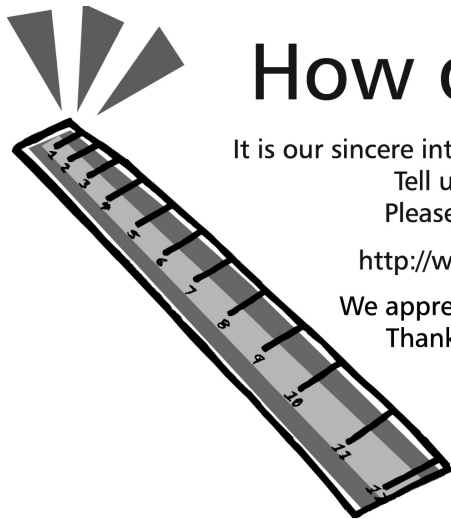

## How did we measure up?

It is our sincere intention to exceed our customer's expectations on every order.  
Tell us whether we achieved our goal on your order.  
Please take our customer satisfaction survey online at:

<http://www.ittindustrialproducts.com/feedbacksurvey.html>

We appreciate you taking the time to provide your feedback.  
Thank you for buying ITT pumps, parts, and controls.

Visit our website at [www.gouldspumps.com](http://www.gouldspumps.com)

