

Contents

Model

EBG2-2115(A)	EBG-31	EBHG2-212C
EBG2-212C	EBG-33	EBHG2-21
EBG2-21	EBG-51	EBHG2-23
EBG2-23	EBG-53	EBHG-31
	EBG-103	EBHG-33
		EBHG-51
		EBHG-53
		EBHG-71
		EBHG-73

Section	Page
Specifications	1-191
Selection Chart	1-192
Performance Curves	1-195
Dimensions	1-204
QDC Information	1-207
Motor Data	1-210
wiring diagrams	
motor electrical data	



Model Designation

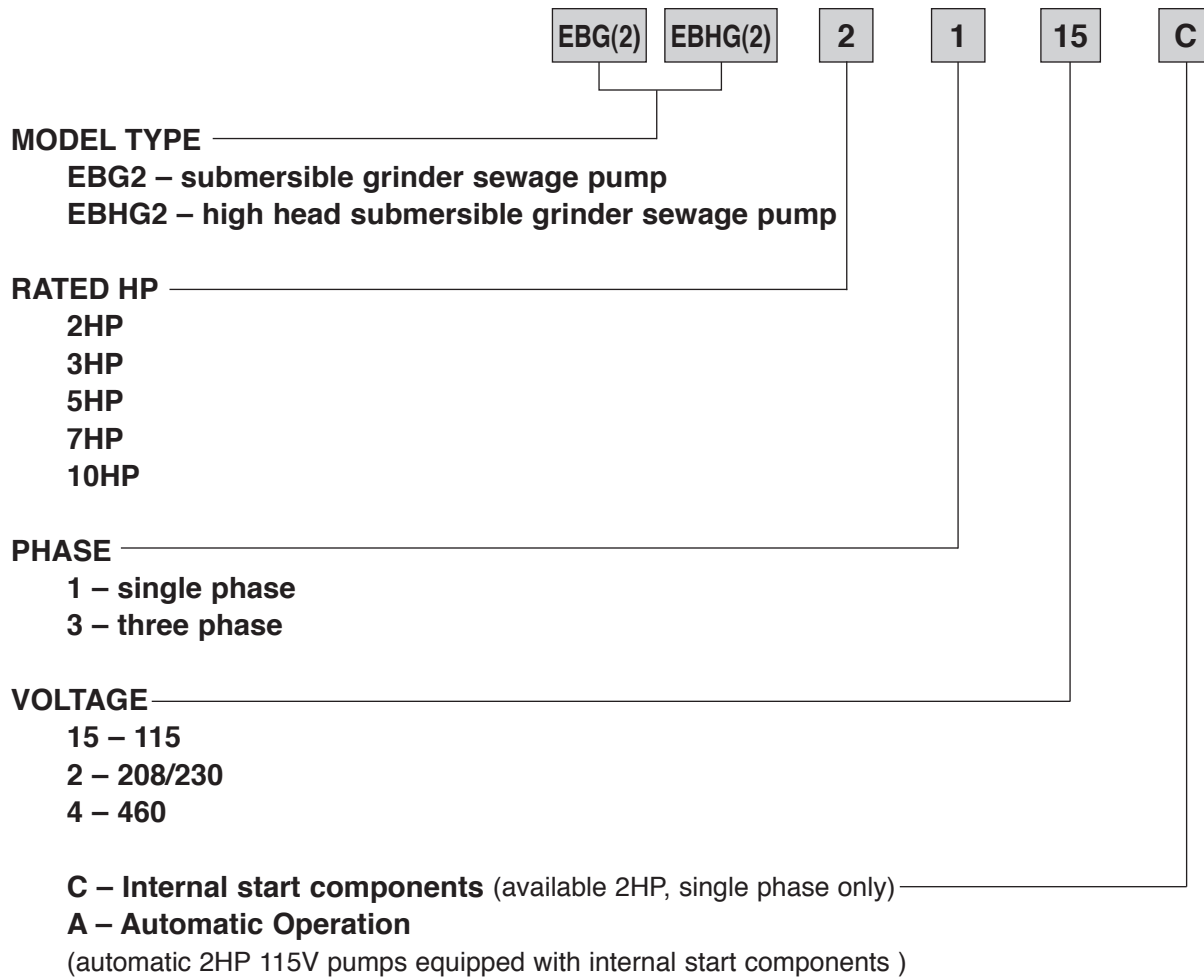

Specifications

Discharge Size/Connection	1 1/4" NPT, 2 1/2", 3" ANSI (3, 5, 7 1/2 10 HP)
Range of HP	2, 3, 5, 7 1/2 10 HP
Range of Performance	Capacity 20 to 190 GPM Head 8 to 175 feet
Limitation	
Maximum Water Temperature	120°F (49°C) [140°F (60°C) intermittent]
Synchronous Speed	3450 RPM
Materials	
Casing	Cast Iron ASTM A-48, Class 30
Impeller	Ductile Iron (2HP models) Cast Brass (3-10HP models)
Shredding Ring	Hardened 440C Stainless Steel, 56-60 Rockwell C
Grinder Impeller	Hardened 440C Stainless Steel, 56-60 Rockwell C
Shaft	416 Stainless Steel
Motor Housing	Cast Iron ASTM A-48, Class 30
Fastener	304 Stainless Steel
Mechanical Seal	Double Mechanical Seal, Type 21
Material – Upper Side	Silicon Carbide/Silicon Carbide
Material – Lower Side	Silicon Carbide/Silicon Carbide
Impeller Type	Recessed Vortex
Bearing – Upper/Lower	Single Row, Ball, Oil Lubricated
– Sleeve Bearing	Bronze with Oil Groove (3, 5, 7 1/2 10 HP)
Motor	Oil-filled, Insulation Class H; Class F (10 HP)
Single Phase	115 V, 208/230V
Three Phase	208/230V only for 3, 5, 7 1/2 10 HP 208/230V, 460V
Motor Protection	Internal moisture detection
Single Phase	Built-in Automatic Overload Protection
Three Phase	Non-overloading on-winding temperature sensor
	Submersible Cable 30 ft. Submersible Cable 40 ft. (3, 5, 7 1/2 10 HP) <i>Consult factory for additional cable lengths.</i>
Accessories	QDC System
Note: Models EBG2-115 and EBG2-212C have Internal start component (Control box not required).	

Selection Chart

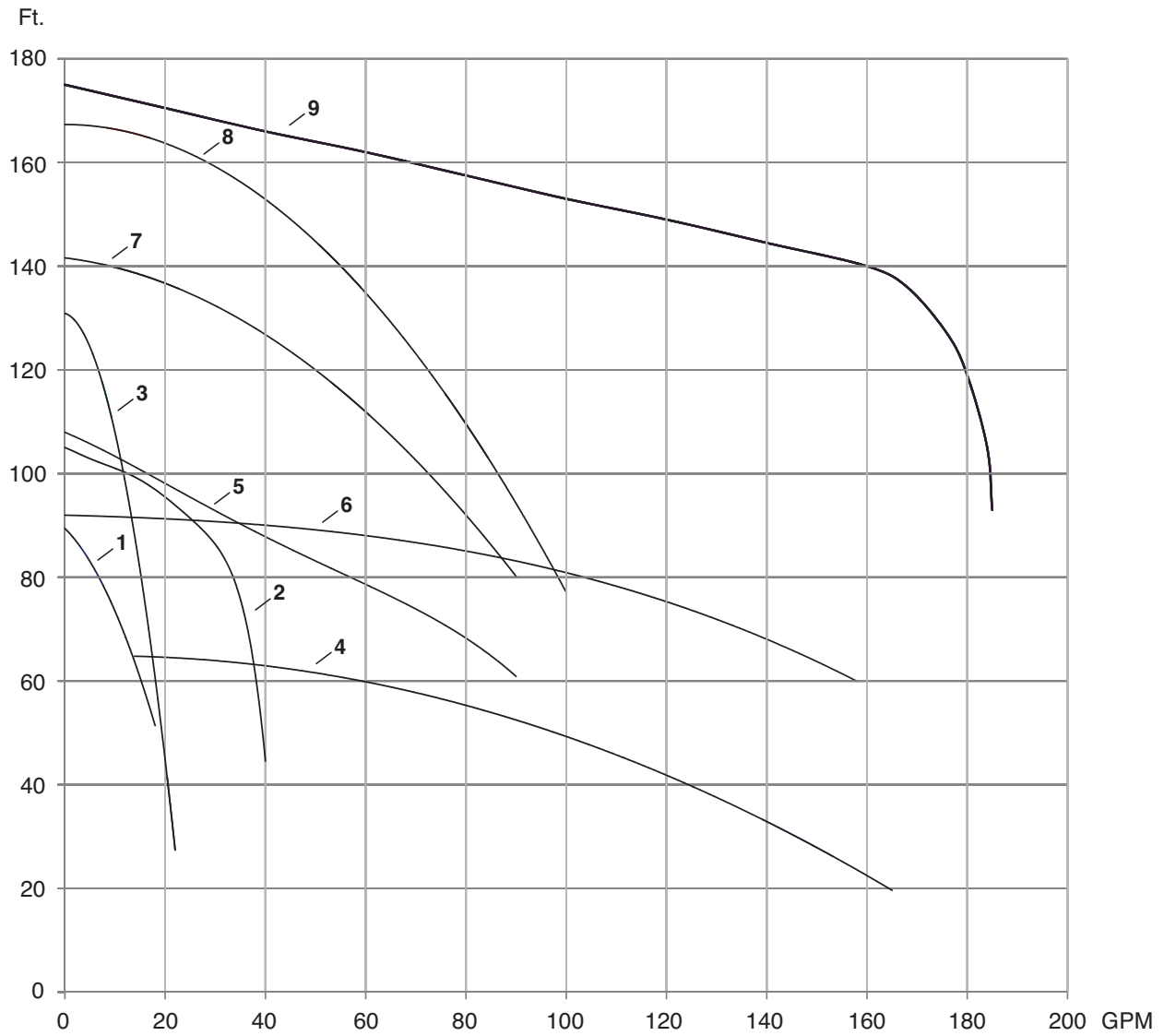

- 1 EBG2-2115 2HP
- 2 EBG2-2 2HP
- 3 EBHG2-2 2HP
- 4 EBG-3 3HP
- 5 EBHG-3 3HP
- 6 EBG-5 5HP
- 7 EBHG-5 5HP
- 8 EBHG-7 7.5HP
- 9 EBG103 10HP



Specifications – 2 HP

Pump Model:

Pump shall be of the centrifugal type with an integrally built-in grinder unit and submersible type motor. The grinder unit shall be capable of macerating all material in normal domestic and commercial sewage, including reasonable amounts of foreign objects such as sanitary napkins, disposable diapers, thin rubber, small wood, plastic and the like to a fine slurry that will easily pass through the pump and 1-1/4" NPT discharge.

Operating Conditions:

The pump shall have a capacity of _____ GPM at a total head of _____ feet, and shall use a motor rated at 2 HP and 3450 RPM.

Pump Impeller:

Ductile Iron threaded on a stainless steel shaft. The impeller shall be of the recessed vortex type to provide an unobstructed passage through the volute for the ground solids.

Grinder Construction:

Both grinder impellers and shredding ring shall be of 440C stainless steel hardened to 56-60 Rockwell C. The grinder assembly shall consist of a grinder impeller and shredding ring mounted directly below the volute passage. The grinder impeller is threaded to a stainless steel shaft, locked with a screw and washer. The shredding ring shall be pressed into the cast iron volute for easy removal. All grinding of solids shall be from the action of the grinder impeller against the shredding ring.

Seals:

Type 21, dual mechanical seal construction mounted in tandem, shall protect the motor. Primary seal shall be silicon / carbide. Secondary seal shall be silicon / carbide. The seal face shall be lapped to a flatness of one light band. An electrode shall be mounted in the seal chamber to detect water entering the chamber through the lower seal. Water in the chamber shall cause a red light to turn on at the control box. This signal shall not stop the motor, but shall act as a warning only, indicating service is required. Single and three phase pumps shall have an internal seal leak probe that signals an alarm in the control panel in the case of water intrusion into the seal chamber [EBG2-2115(A), EB(H)G2-21C excluded].

Motor:

The pump motor shall be of the submersible type, rated 2 HP, 3450 RPM. The motor shall be for 60 Hz, either 115, 208, 230, 460 volt, single or three phase operation. Single-phase motors shall be capacitor start, capacitor run type for high starting torque. For the 115V motor, run capacitor ratings shall not exceed 300 volts. The motor will utilize mechanical starting switch. Start and run capacitors, and electronic relay for operating the motor will be found in the control box. Major motor operating temperature must not exceed Class B ratings.

The stator winding shall be of the open type with Class H insulation. Winding housing shall be filled with clean, high dielectric oil that lubricates bearings and seals, transferring heat from windings and rotor to the outer cast housing.

The motor shall have two heavy-duty ball bearings to support the pump shaft, taking radial and thrust loadings. Ball bearings shall be designed for a minimum 50,000 hours B-10 life. The stator shall be pressed into the motor housing. The common motor pump and grinder shaft shall be of 416 SST, threaded to take the pump and grinder impeller.

Single-phase motors shall have automatic reset overload protection attached to the top end of the motor windings to stop the motor if the motor winding temperature reaches 130 degrees C. The high temperature shut-off will cause the pump to cease operation, should a control failure cause the pump to run in a dry wet well. The overload shall automatically reset when the motor cools to a safe operating temperature. Three phase motors contain temperature sensors with (2) wires for attachment to the control panel.

Power Cord:

The motor power cord shall be 12 Ga. SOW/SJOWA or SOOW. The cable jacket shall be sealed at the motor entrance by means of a rubber compression washer and compression nut. An epoxy filled tube shall seal the outer cable jacket and individual leads to prevent water from entering the motor housing. Individual conductor strands shall be soldered within.



Specifications – 3, 5, 7.5 10 HP

Pump Model:

Pump shall be of the centrifugal type with an integrally built-in grinder unit and submersible type motor. The grinder unit shall be capable of macerating all material in normal domestic and commercial sewage, including reasonable amounts of foreign objects such as sanitary napkins, disposable diapers, thin rubber, small wood, plastic and the like to a fine slurry that easily pass through the pump and 2" discharge pipe. Discharge shall be standard with slotted bolt pattern to accommodate either a 2.5" or 3" 150 lb. ANSI flange.

Operating Conditions:

The pump shall have a capacity of _____ GPM at a total head of _____ feet, and shall use a motor rated at _____ HP and 3450 RPM.

Pump Impeller:

Cast brass and threaded on a stainless steel shaft. The impeller shall be of the recessed vortex type to provide an unobstructed passage through the volute for the ground solids.

Grinder Construction:

Both grinder impellers and shredding ring shall be of 440C stainless steel hardened to 56-60 Rockwell C. The grinder assembly shall consist of a grinder impeller and shredding ring mounted directly below the volute passage. The grinder impeller is threaded to a stainless steel shaft, locked with a screw and washer. The shredding ring shall be pressed into an iron holding flange for easy removal. The flange shall be provided with tapped back-off holes so screws can be used to push the shredding ring from the housing. All grinding of solids shall be from the action of the grinder impeller against the shredding ring.

Seals:

Type 21, dual mechanical seal construction mounted in tandem, shall protect the motor. Primary seal shall be silicon / carbide. Secondary seal shall be silicon / carbide. The seal face shall be lapped to a flatness of one light band. A double electrode shall be mounted in the seal chamber to detect water entering the chamber through the lower seal. Water in the chamber shall cause a red light to turn on at the control box. This signal shall not stop the motor, but shall act as a warning only, indicating service is required.

Motor:

The pump motor shall be of the submersible type, rated _____ HP, 3450 RPM. The motor shall be for 60 Hz, either 208, 230 or 460 volt, single or three-phase operation. Major operating temperature must not exceed Class B ratings.

The stator winding shall be of the open type with Class H (Class F - 10 HP) insulation. Winding housing shall be filled with clean, high dielectric oil that lubricates bearings and seals, transferring heat from windings and rotor to the outer cast housing.

An upper motor bearing cap shall be a separate casting for easy mounting and replacement. The motor shall have two heavy-duty ball bearings to support the pump shaft, taking radial and thrust loadings. A sleeve guide bushing is mounted directly above the lower seal to take radial load and act as a flame path for the seal chamber. Ball bearings shall be designed for a minimum 50,000 hours B-10 life. The stator shall be pressed into the motor housing. The common motor pump and grinder shaft shall be of 416 SST, threaded to take the pump and grinder impeller.

Motors shall have a heat sensor thermostat attached to the top end of the motor windings to stop the motor if the motor winding temperature reaches 200 degrees F. The high temperature shut-off will cause the pump to cease operation, should a control failure cause the pump to run in a dry wet well. The thermostat shall automatically reset when the motor cools to a safe operating temperature.

Power Cord:

The motor power cord shall be 10 Ga. SOW/SOWA or SOOW. The cable jacket shall be sealed at the motor entrance by means of a rubber compression washer and compression nut. An epoxy filled tube shall seal the outer cable jacket and individual leads to prevent water from entering the motor housing. Individual conductor strands shall be soldered within the epoxy seal. Cords shall withstand a pull of 300 pounds.



Performance Curves

Project: _____ GPM: _____ TDH: _____ EFF: _____ HP: _____ Chk'd: _____ Date: _____

EBG2-2115(A) (2HP) Synchronous Speed: 3450 RPM 1¼ inch Discharge

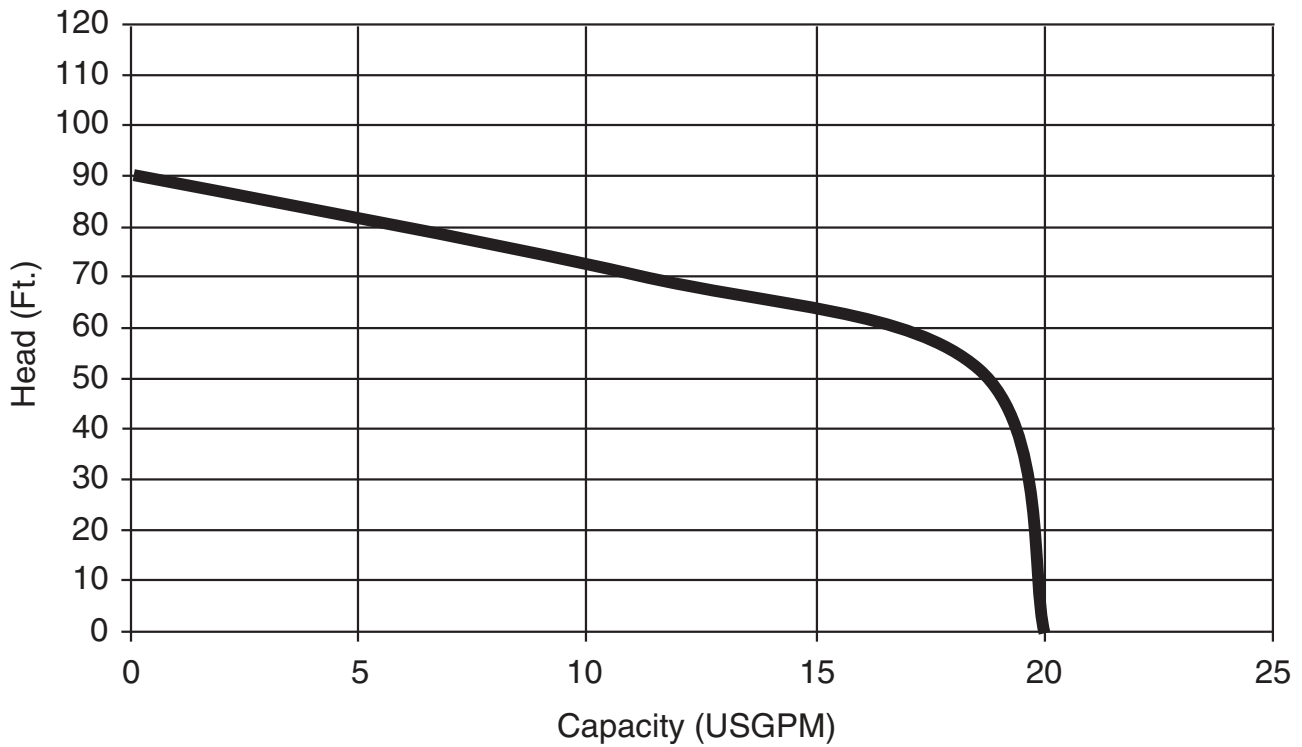

EBG2-212C (2HP) Synchronous Speed: 3450 RPM 1¼ inch Discharge

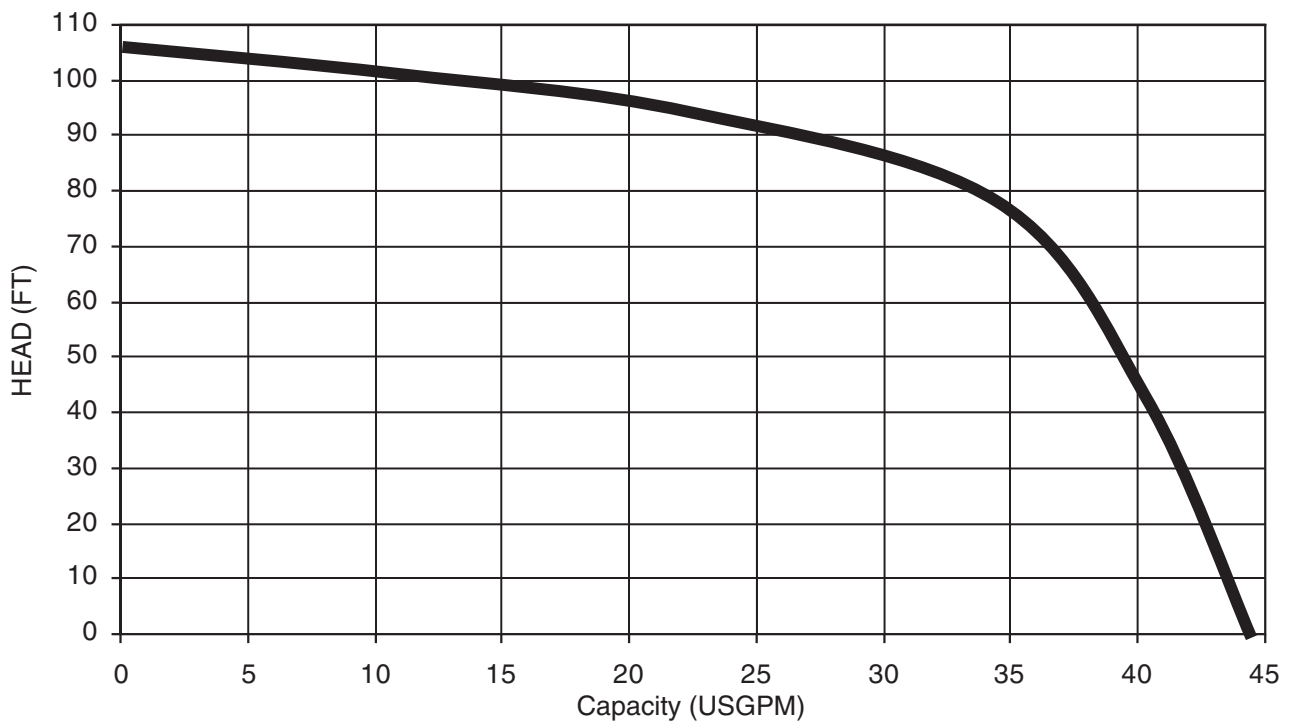

Performance Curves

Project: _____ GPM: _____ TDH: _____ EFF: _____ HP: _____ Chk'd: _____ Date: _____

EBHG2-212C (2HP) Synchronous Speed: 3450 RPM 1¼ inch Discharge

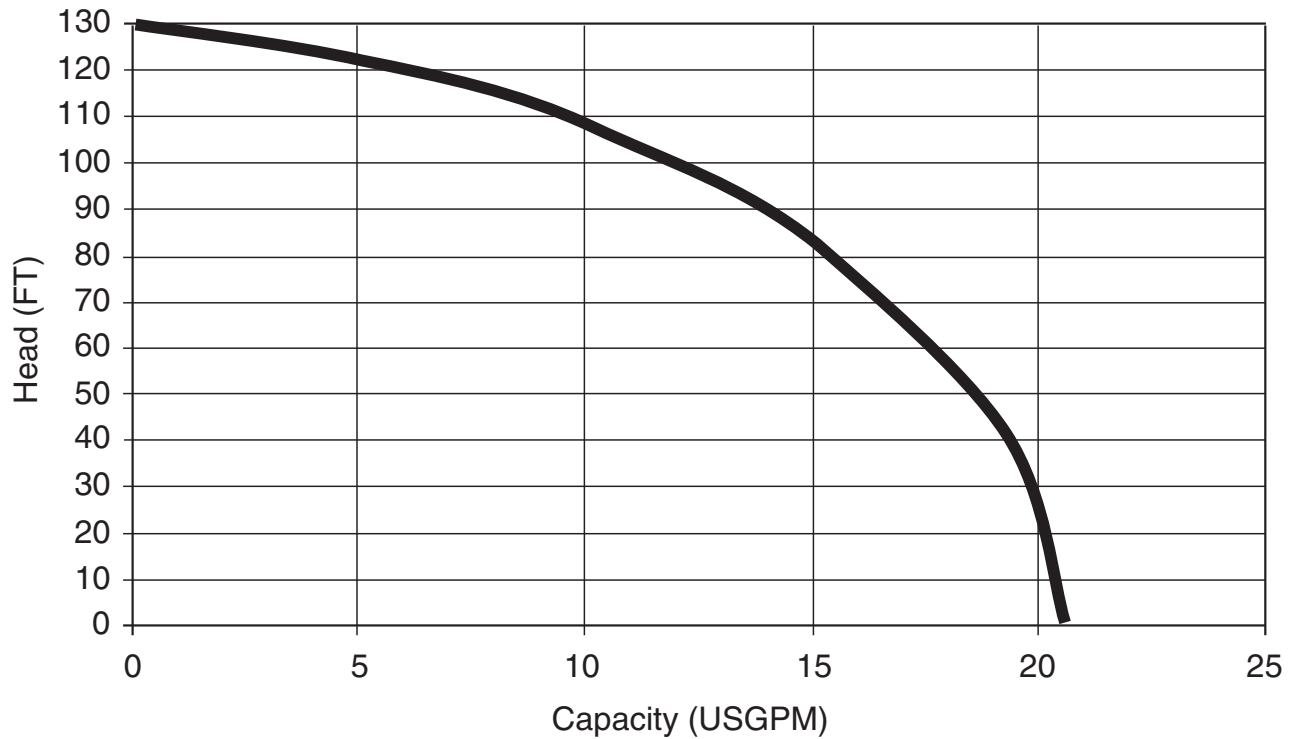

EBG2-21 (2HP) Synchronous Speed: 3450 RPM 1¼ inch Discharge

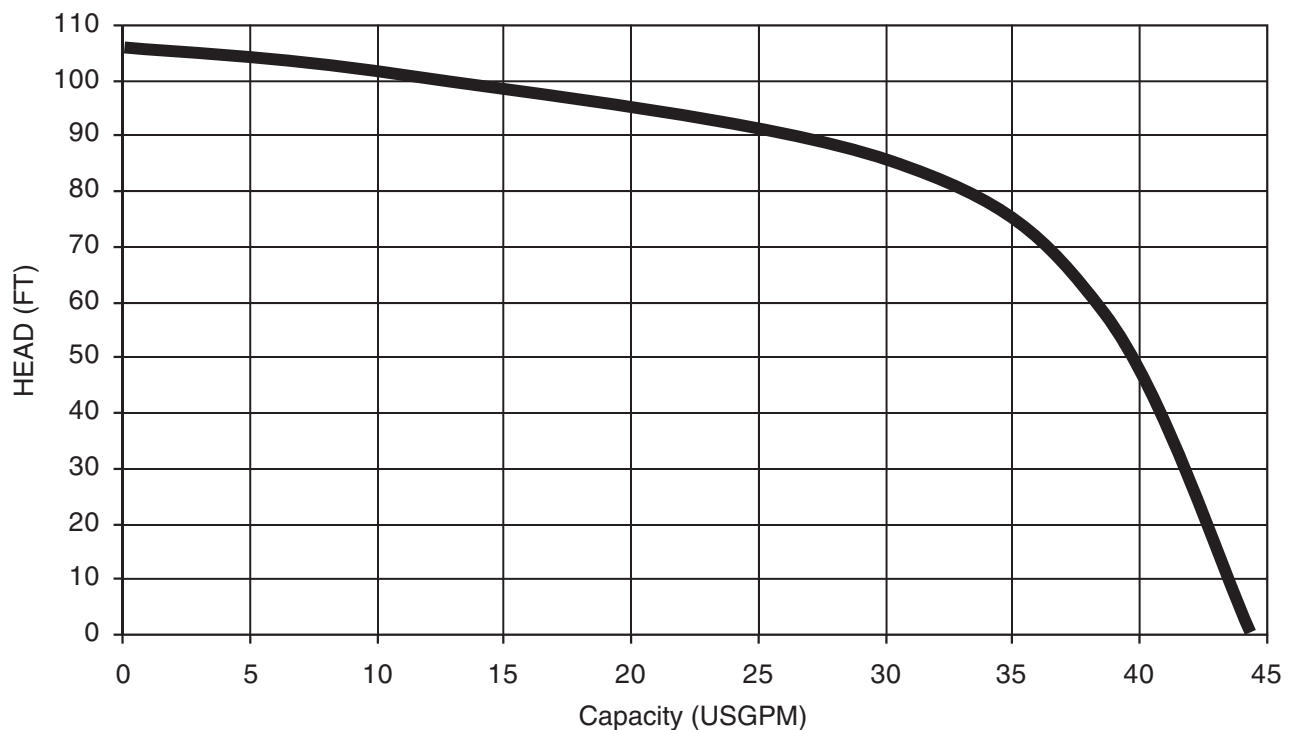

Performance Curves

Project: _____ GPM: _____ TDH: _____ EFF: _____ HP: _____ Chk'd: _____ Date: _____

EBG2-23 (2HP) Synchronous Speed: 3450 RPM 1¼ inch Discharge

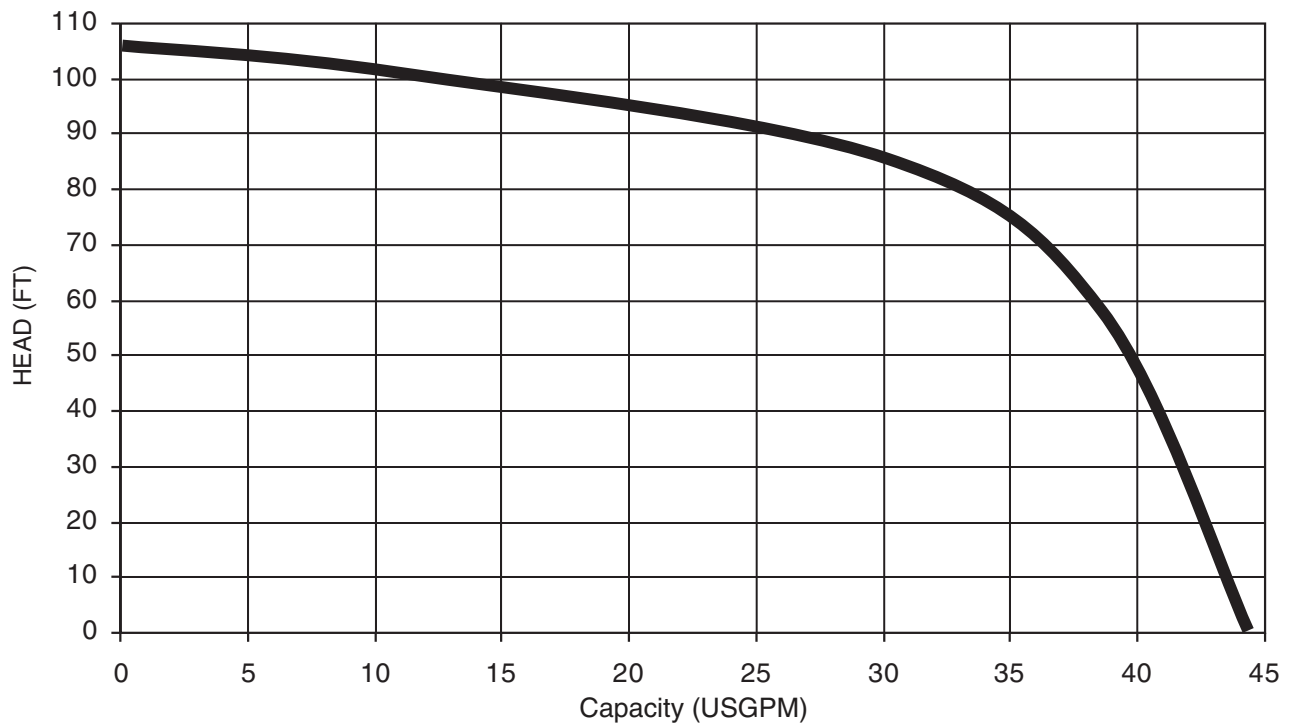

EBHG2-21 (2HP) Synchronous Speed: 3450 RPM 1¼ inch Discharge

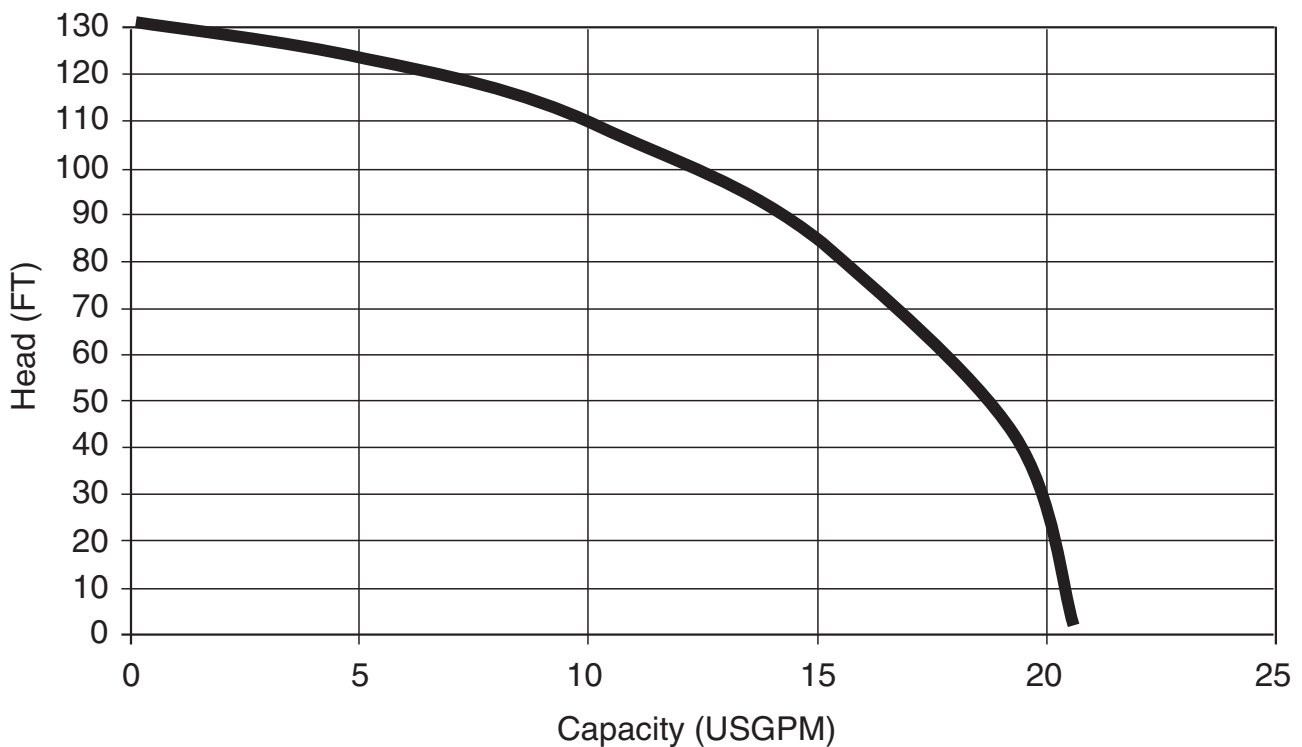

Performance Curves

Project: _____ GPM: _____ TDH: _____ EFF: _____ HP: _____ Chk'd: _____ Date: _____

EBHG2-23 (2HP) Synchronous Speed: 3450 RPM 1¼ inch Discharge

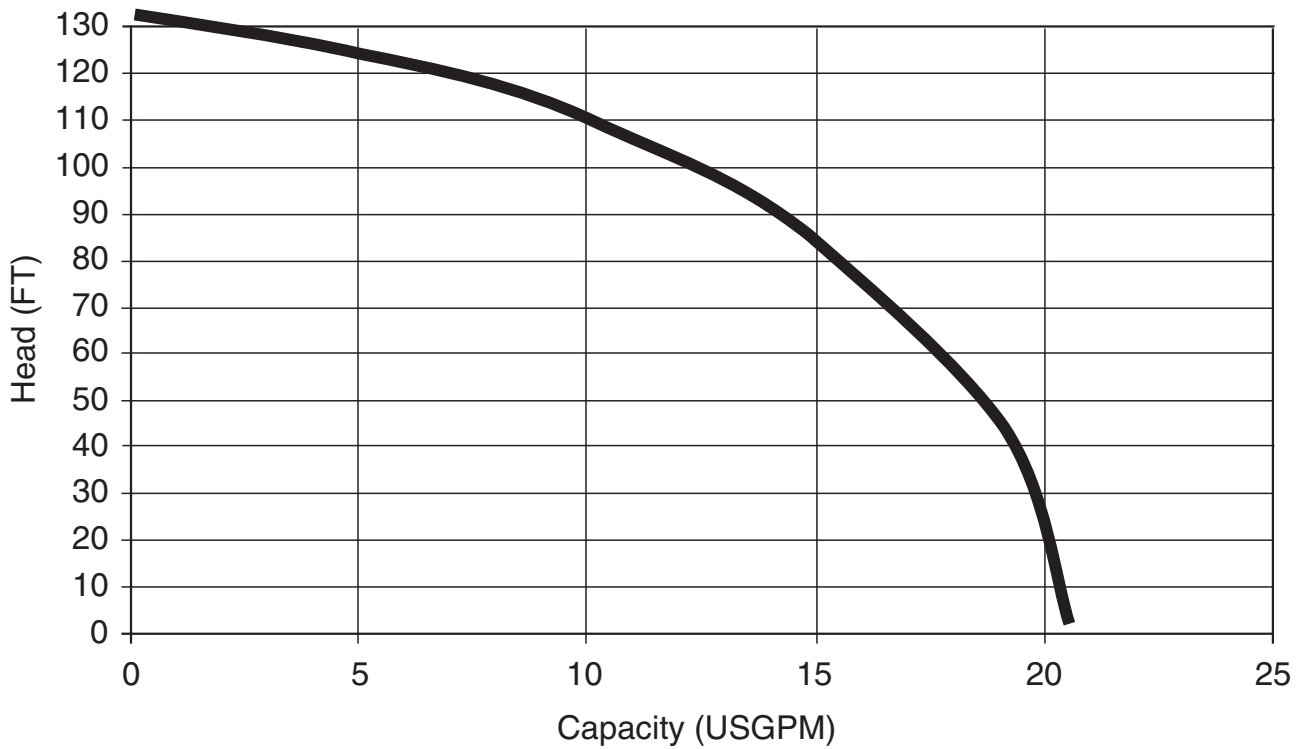

EBG-31 (3HP) Synchronous Speed: 3450 RPM 2½ / 3 inch Discharge

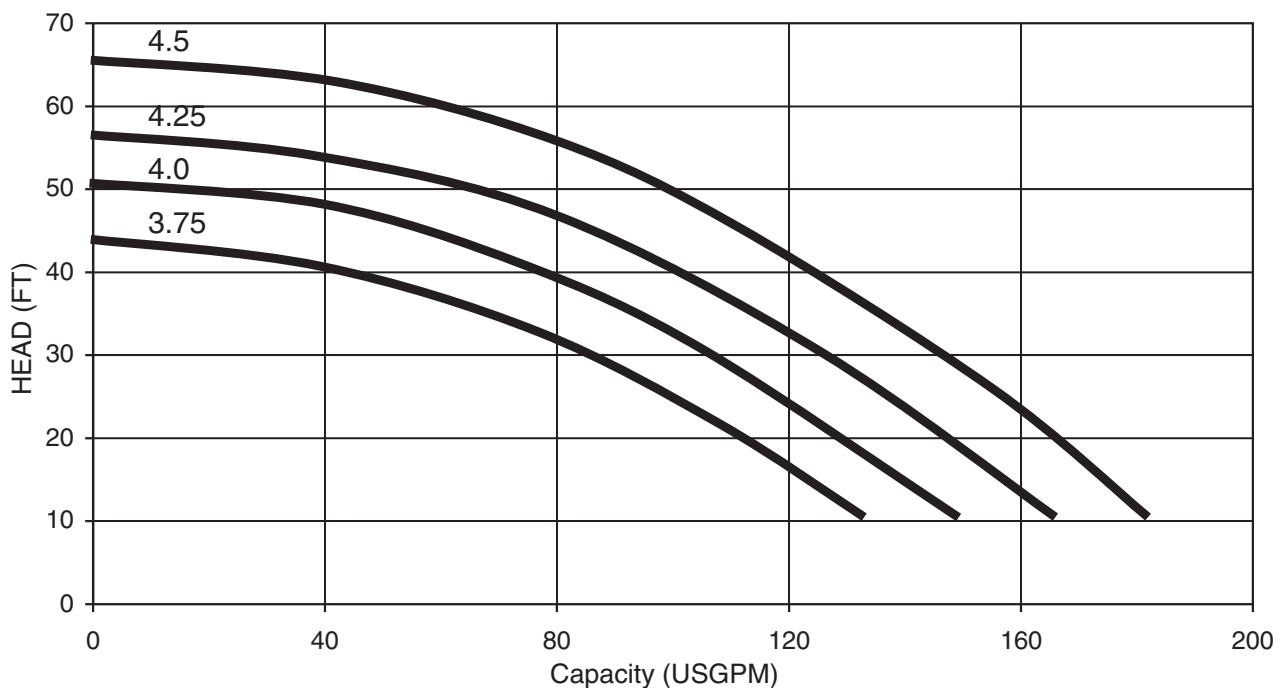

Note: Full diameter impeller included in price of pump. Consult factory for reduced diameter impeller and pricing.

Performance Curves

Project: _____ GPM: _____ TDH: _____ EFF: _____ HP: _____ Chk'd: _____ Date: _____

EBG-33 (3HP) Synchronous Speed: 3450 RPM 2 1/2 / 3 inch Discharge

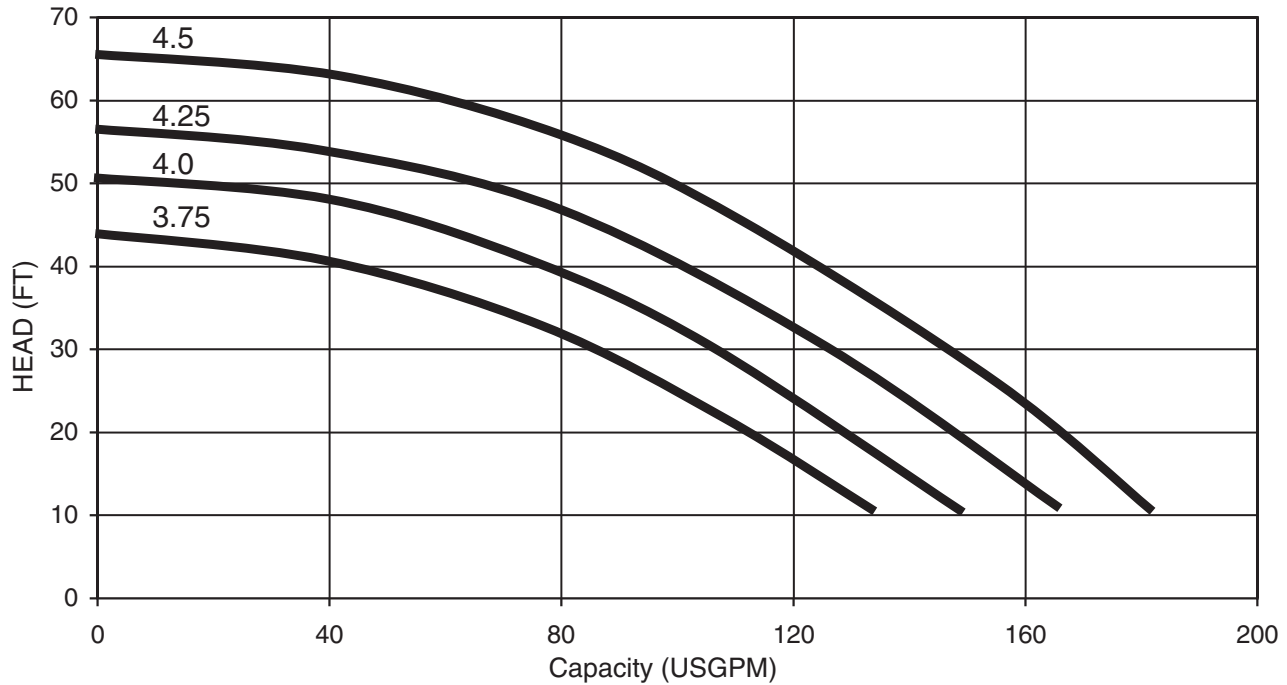

Note: Full diameter impeller included in price of pump. Consult factory for reduced diameter impeller and pricing.

EBG-51 (5HP) Synchronous Speed: 3450 RPM 2 1/2 / 3 inch Discharge

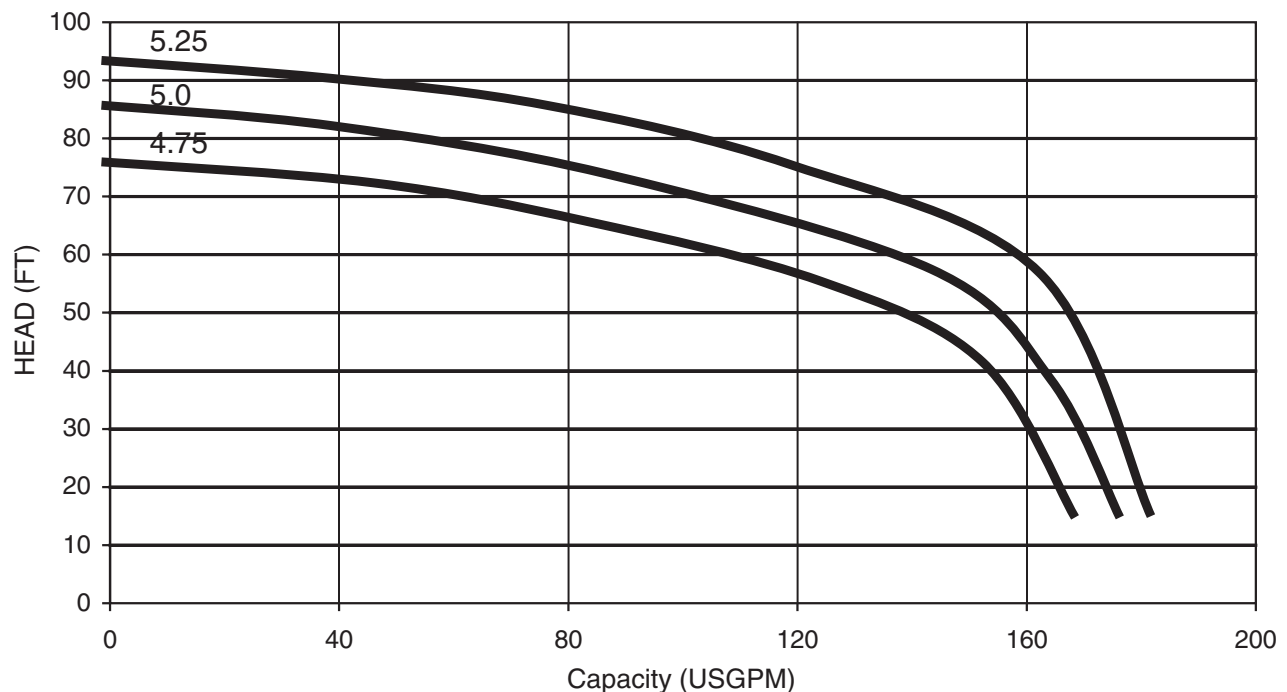

Note: Full diameter impeller included in price of pump. Consult factory for reduced diameter impeller and pricing.

Performance Curves

Project: _____ GPM: _____ TDH: _____ EFF: _____ HP: _____ Chk'd: _____ Date: _____

EBHG-31 (3HP) Synchronous Speed: 3450 RPM 2 1/2 / 3 inch Discharge

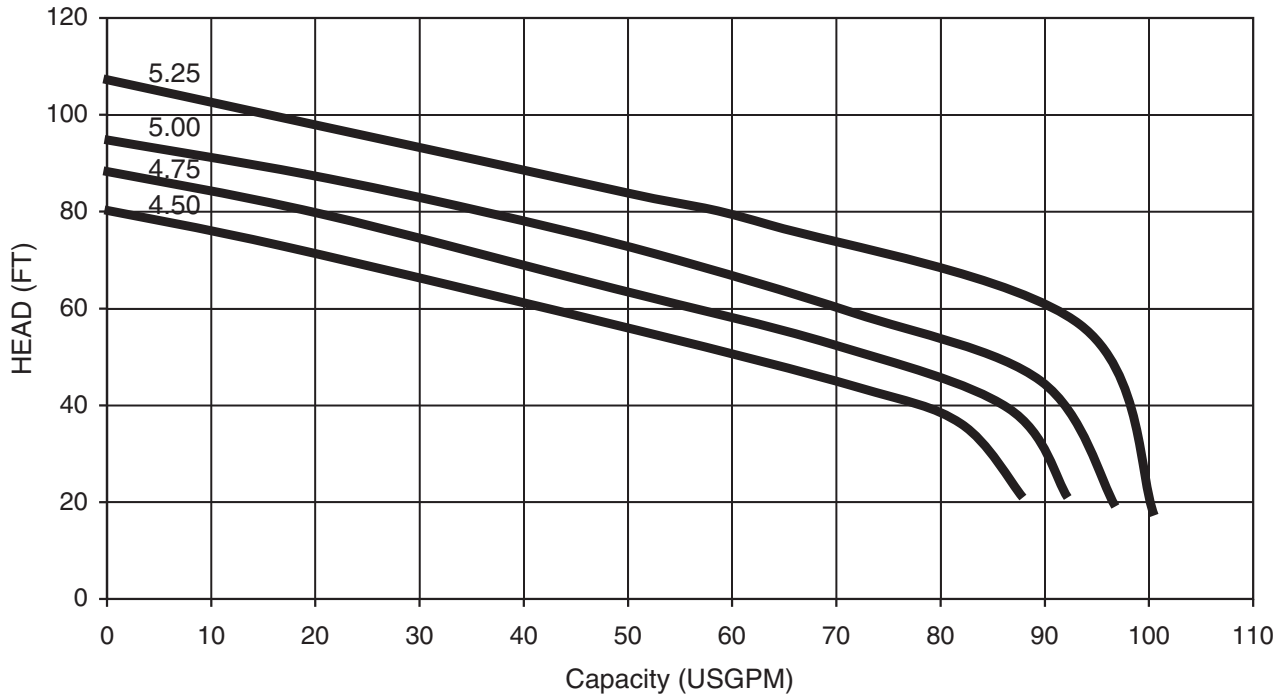

Note: Full diameter impeller included in price of pump. Consult factory for reduced diameter impeller and pricing.

EBHG-33 (3HP) Synchronous Speed: 3450 RPM 2 1/2 / 3 inch Discharge

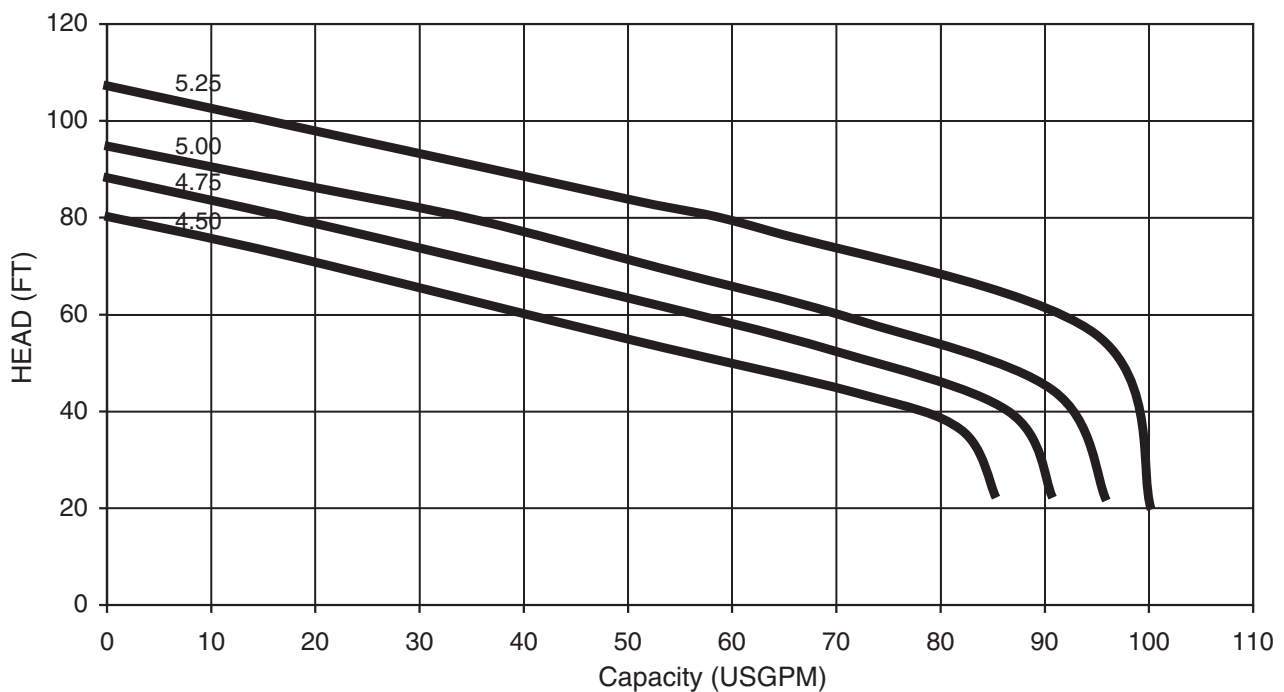

Note: Full diameter impeller included in price of pump. Consult factory for reduced diameter impeller and pricing.

Performance Curves

Project: _____ GPM: _____ TDH: _____ EFF: _____ HP: _____ Chk'd: _____ Date: _____

EBHG-51 (5HP) Synchronous Speed: 3450 RPM 2 1/2 / 3 inch Discharge

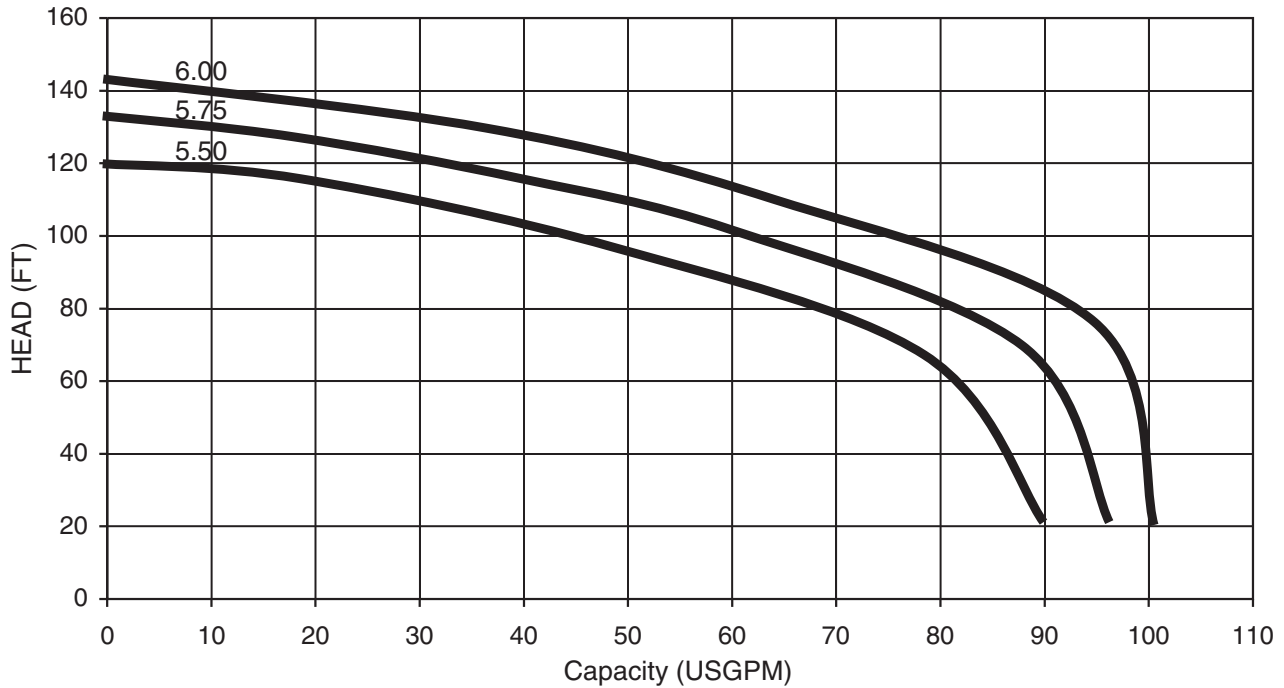

Note: Full diameter impeller included in price of pump. Consult factory for reduced diameter impeller and pricing.

EBHG-53 (5HP) Synchronous Speed: 3450 RPM 2 1/2 / 3 inch Discharge

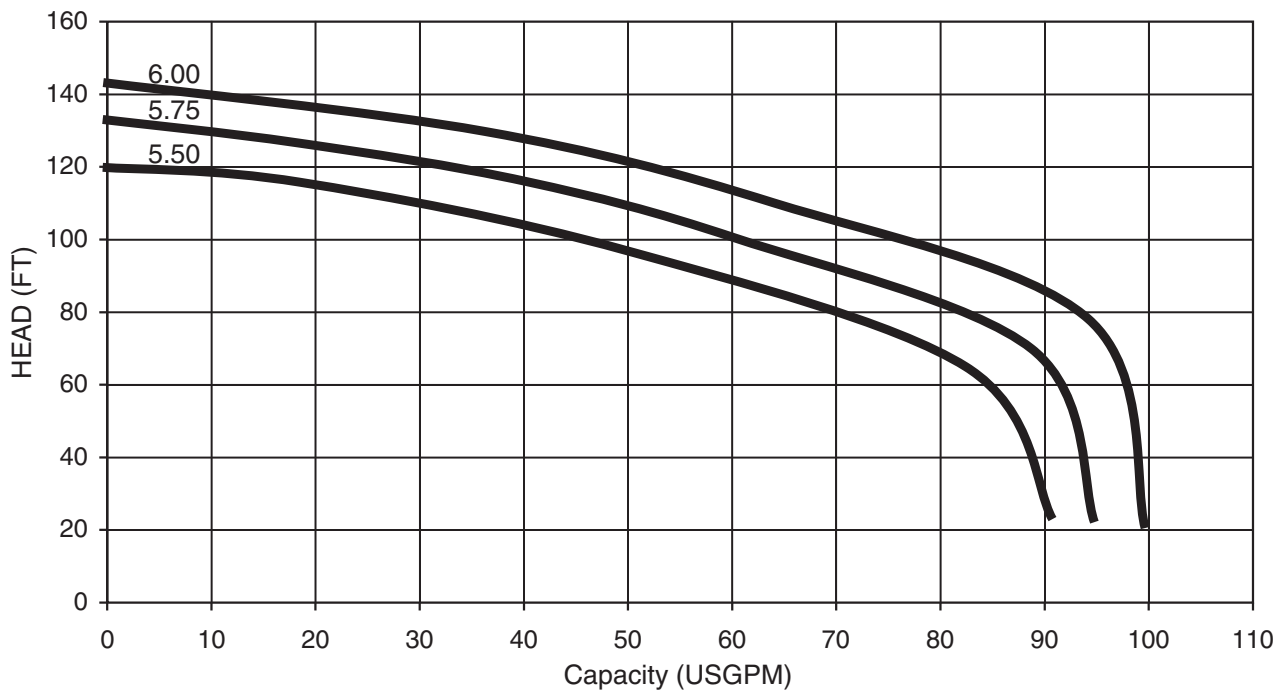

Note: Full diameter impeller included in price of pump. Consult factory for reduced diameter impeller and pricing.

Performance Curves

Project: _____ GPM: _____ TDH: _____ EFF: _____ HP: _____ Chk'd: _____ Date: _____

EBHG-71 (7½ HP) Synchronous Speed: 3450 RPM 2½ / 3 inch Discharge

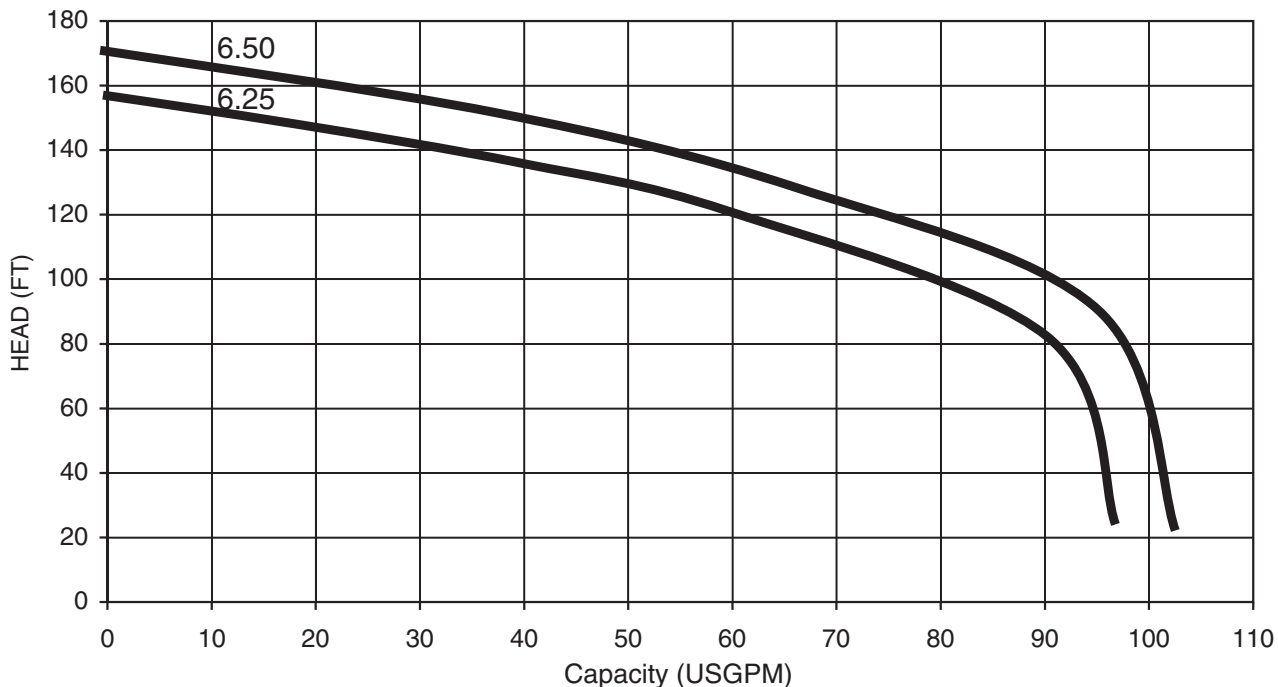

Note: Full diameter impeller included in price of pump. Consult factory for reduced diameter impeller and pricing.

EBHG-73 (7½ HP) Synchronous Speed: 3450 RPM 2½ / 3 inch Discharge

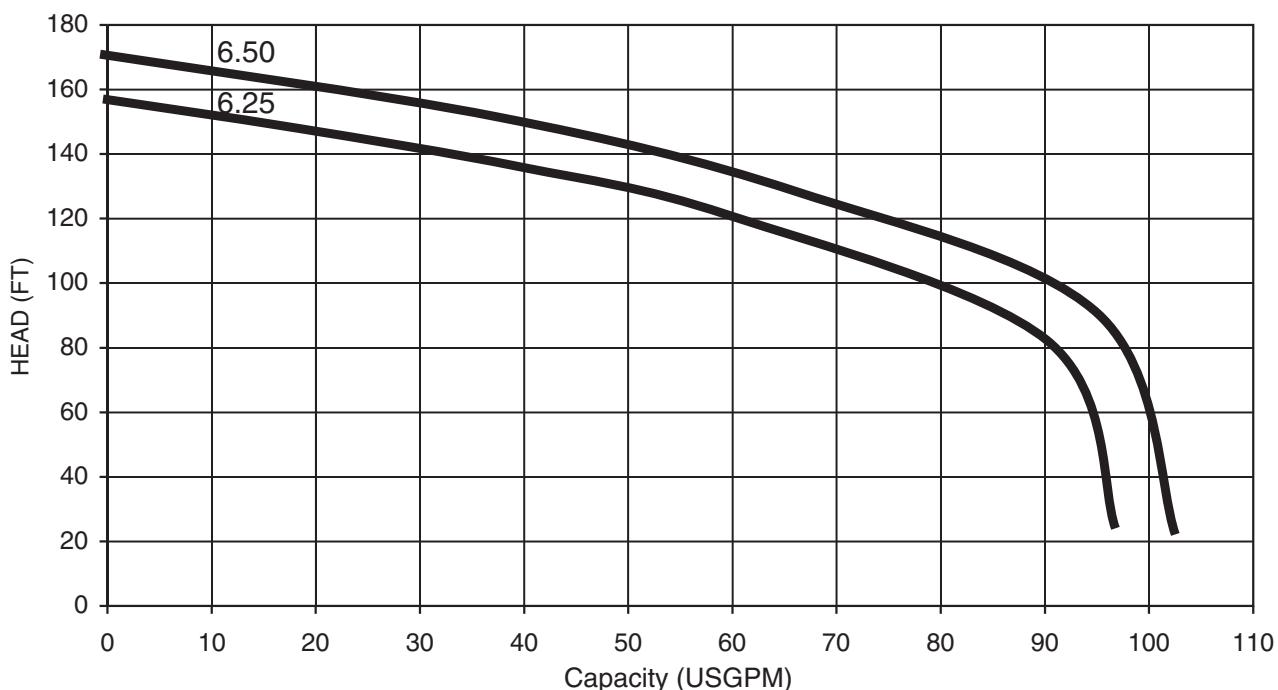

Note: Full diameter impeller included in price of pump. Consult factory for reduced diameter impeller and pricing.

Dimensions

Project: _____ Model: _____ Chk'd: _____ Date: _____

Model EB(H)G

2 HP

Unit: inch

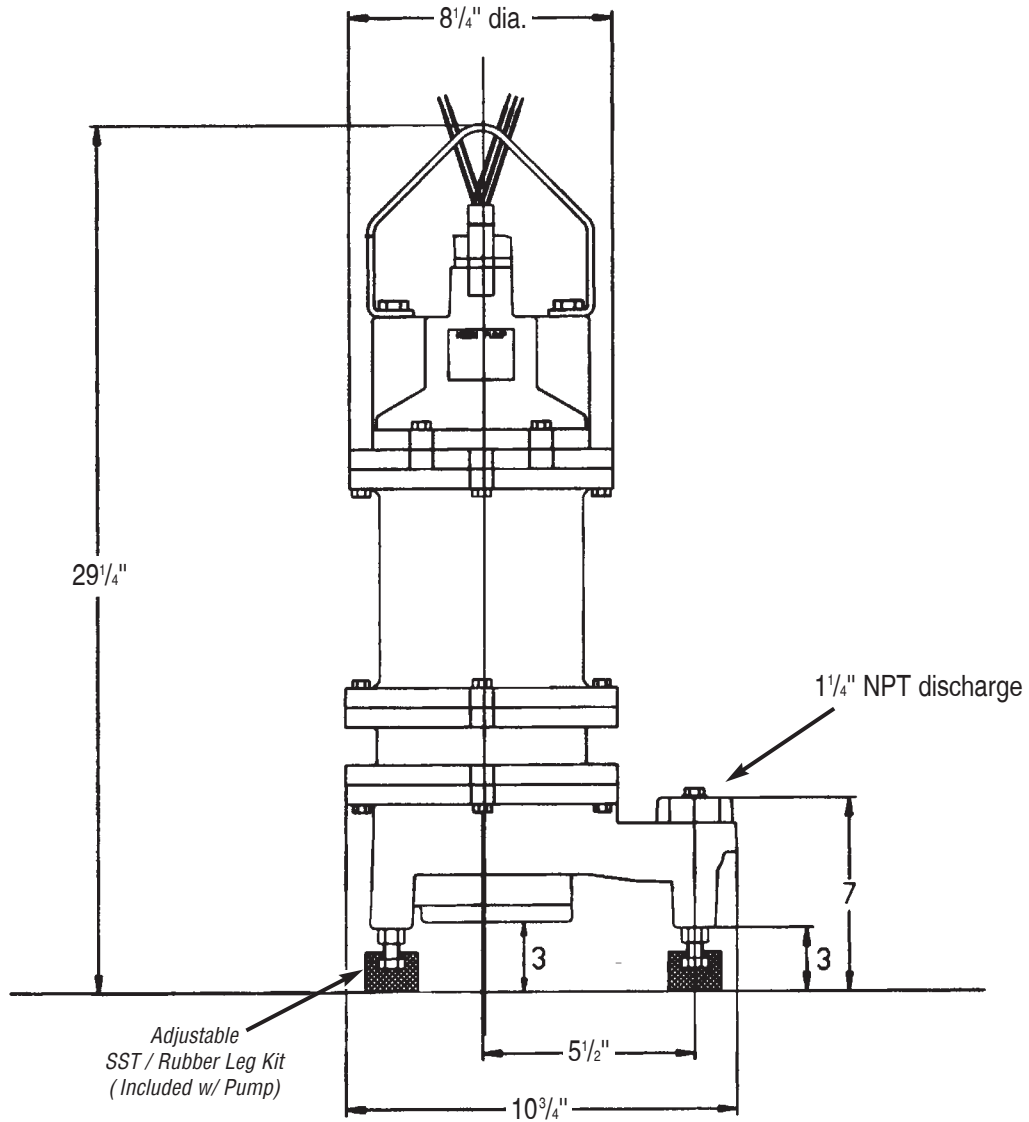

MODEL	WEIGHT - Lb
EBG2-2115(A)	83
EBG2-212C	88
EBHG2-212C	88
EBG2-21	88
EBG2-23	88
EBHG2-21	88
EBHG2-23	88

Dimensions

Project: _____ Model: _____ Chk'd: _____ Date: _____

Model EB(H)G
 3, 5, 7.5, 10HP
 Unit: inch

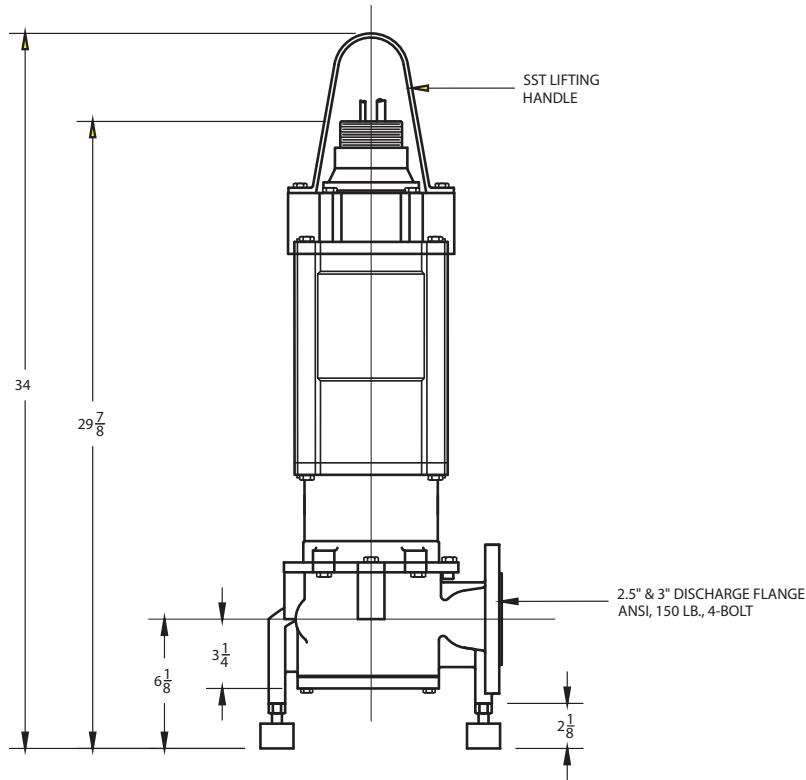
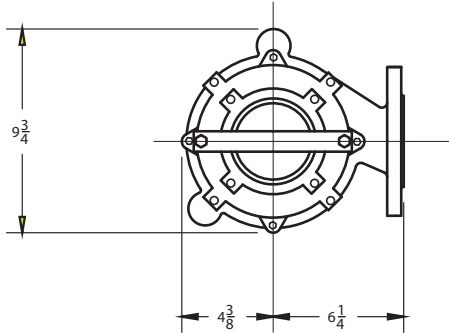

MODEL	WEIGHT – Lb (kg)
EBG-31	190
EBG-33	190
EBG-51	190
EBG-53	190
EBG-103	210
EBHG-31	190
EBHG-33	190
EBHG-51	190
EBHG-53	190
EBHG-71	190
EBHG-73	190



Dimensions – Lift Out Dimensions

Project: _____ Model: _____ Chk'd: _____ Date: _____

Lift Out Dimensions

Model EB(H)G

3, 5, 7.5, 10HP

Unit: inch

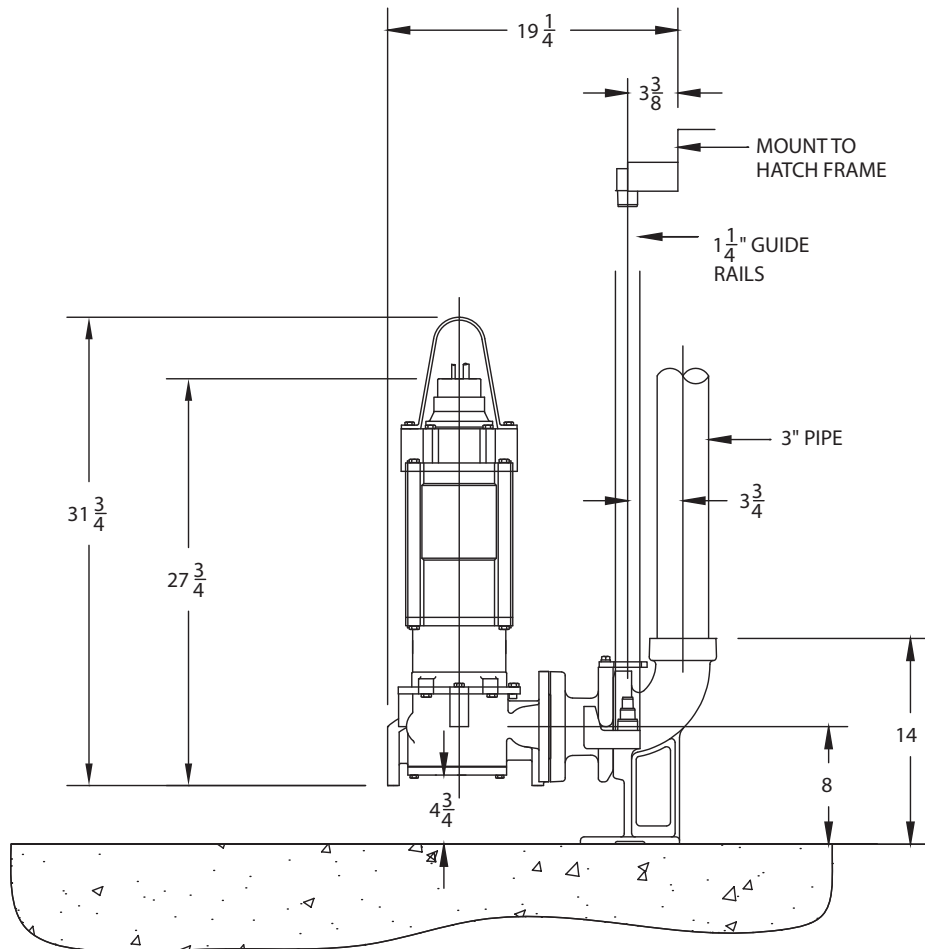
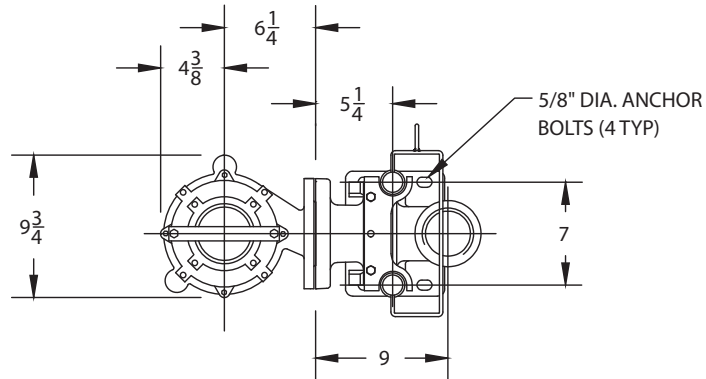

Dimensions

Project: _____ Model: _____ Chk'd: _____ Date: _____

Quick Discharge Connector Model RS1

Model EB(H)G

EBG, 2HP

EBHG, 2HP

RS1 weight = 52 lbs

NOTE: ALL DIMENSIONS ARE IN INCHES.
 MATERIALS OF CONSTRUCTION:
 BASE ELBOW: CAST IRON
 LIFT-OUT FLANGE: CAST IRON
 LOWER GUIDE BRACKET: 304 SST
 ALL FASTENERS ARE 304 SERIES SST
 USEABLE RAIL SIZES: $\frac{3}{4}$ " & 1"
 MAXIMUM WEIGHT ALLOWANCE: 200lbs.

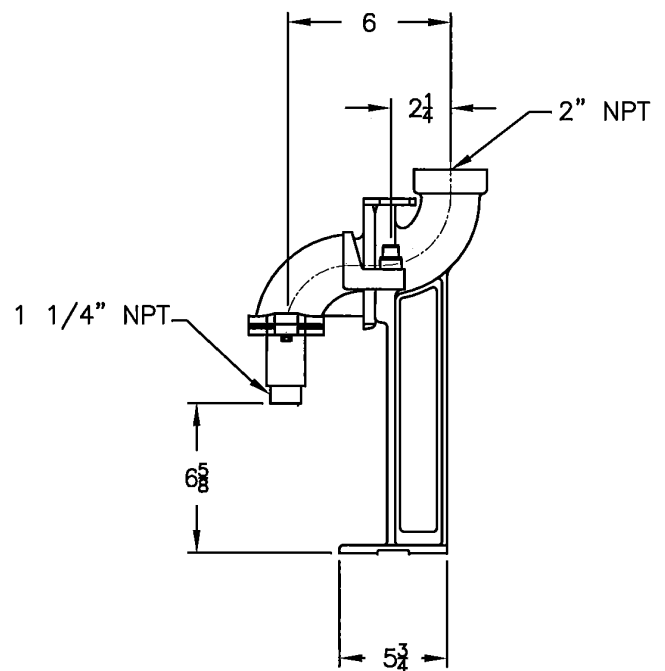
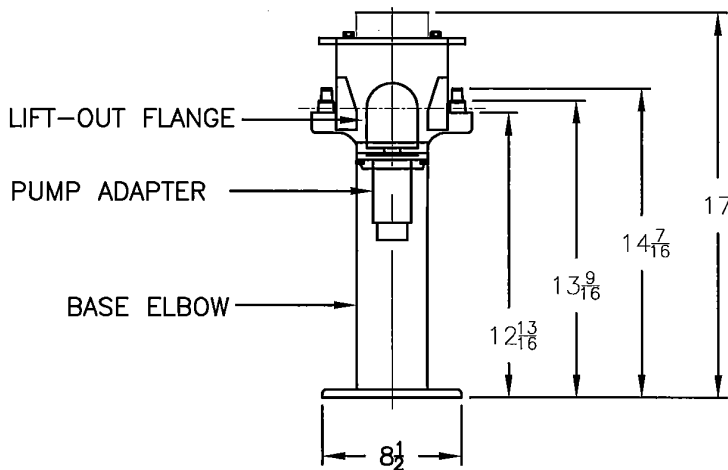
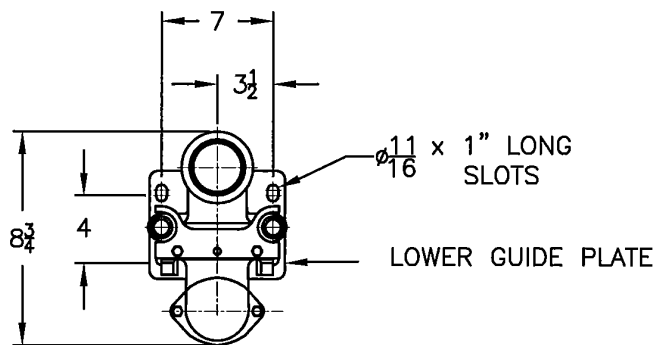

Dimensions

Project: _____ Model: _____ Chk'd: _____ Date: _____

Quick Discharge Connector Model RS3-H

Model EB(H)G

EBG, 3, 5, 10HP

EBHG, 3, 5, 7.5HP

RS3-H weight = 70 lbs

NOTE: ALL DIMENSIONS ARE IN INCHES.

MATERIALS OF CONSTRUCTION:

BASE ELBOW: CAST DUCTILE IRON

LIFT-OUT FLANGE: CAST DUCTILE IRON

LOWER GUIDE BRACKET: 304 SST

ALL FASTENERS ARE 304 SERIES SST

USEABLE GUIDE RAIL SIZES: $\frac{3}{4}$ ", 1", $1\frac{1}{4}$ "

MOUNTING DIMENSIONS

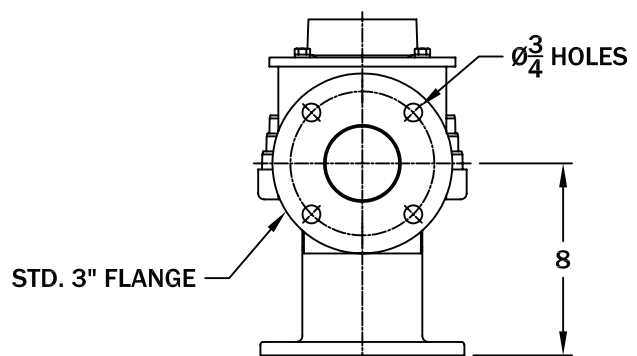
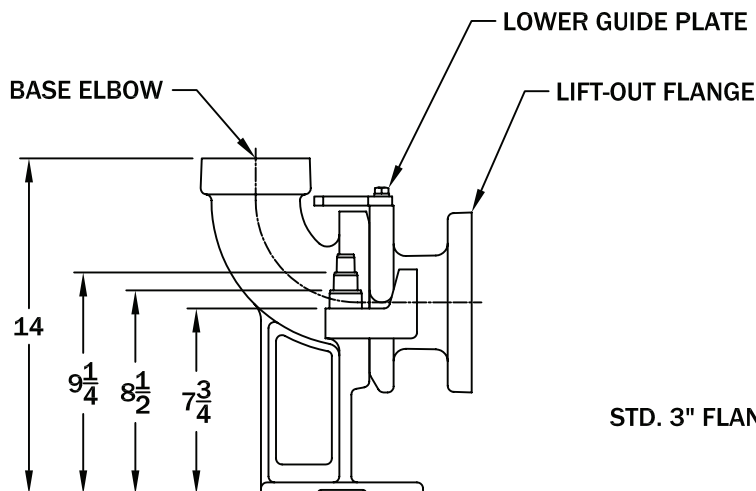
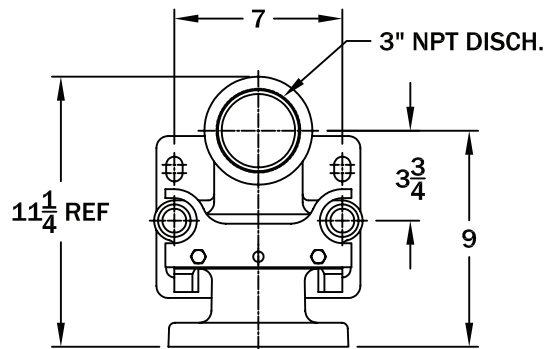
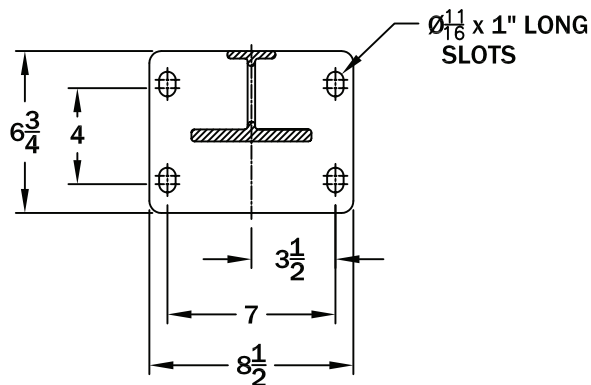

Dimensions

Project: _____ Model: _____ Chk'd: _____ Date: _____

Upper Guide Brackets

NOTE: MOUNTING SLOTS ARE $\varnothing \frac{7}{16}$
 ACCOMMODATES $\frac{3}{4}$, 1 AND 1 $\frac{1}{4}$ INCH PIPE

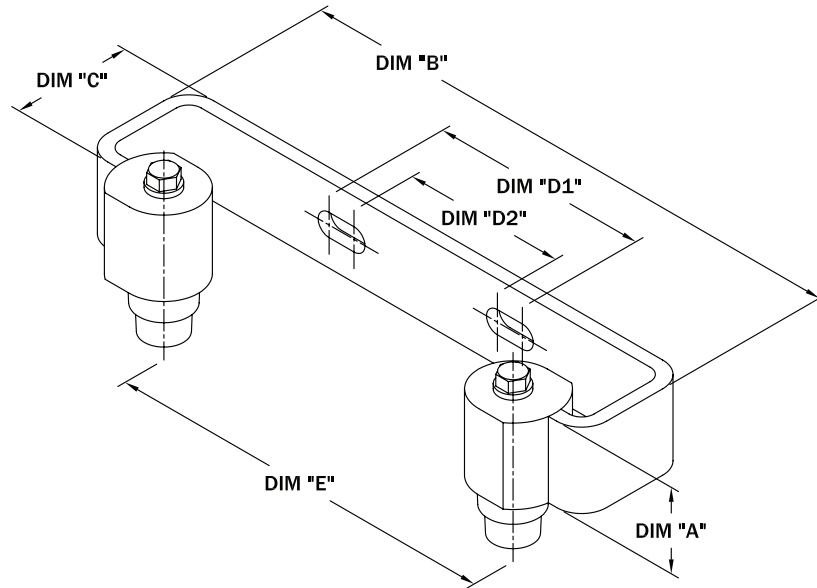

MODEL NO.	DIA. "A"	DIM "B"	DIM "C"	DIM "D1"	DIM "D2"	DIM "E"
UGB-SS	1 1/2"	10"	2 1/8"	3 7/8"	2 7/8"	7"

Intermediate Guide Brackets

NOTE: IGB-075-SS USED FOR $\frac{3}{4}$ " RAILS
 IGB-100-SS USED FOR 1" RAILS
 IGB-125-SS USED FOR 1 $\frac{1}{4}$ " RAILS
 MOUNTING SLOTS ARE $\varnothing \frac{7}{16}$

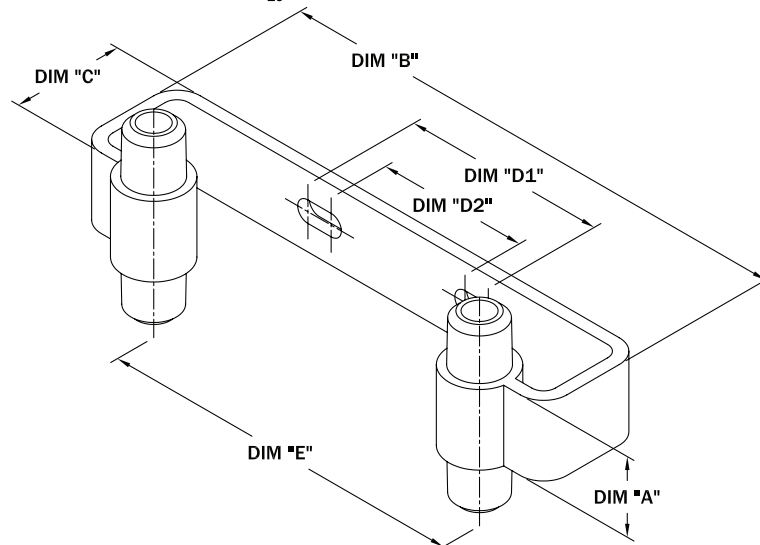

MODEL NO.	DIA. "A"	DIM "B"	DIM "C"	DIM "D1"	DIM "D2"	DIM "E"
IGB-075-SS	1 1/2"	10"	2 1/8"	3 7/8"	2 7/8"	7"
IGB-100-SS	1 1/2"	10"	2 1/8"	3 7/8"	2 7/8"	7"
IGB-125-SS	1 1/2"	10"	2 1/8"	3 7/8"	N/A	7"

Motor Wiring Diagram

Project: _____ Model: _____ Chk'd: _____ Date: _____

EBG2-115
2HP, 115V, Single Phase

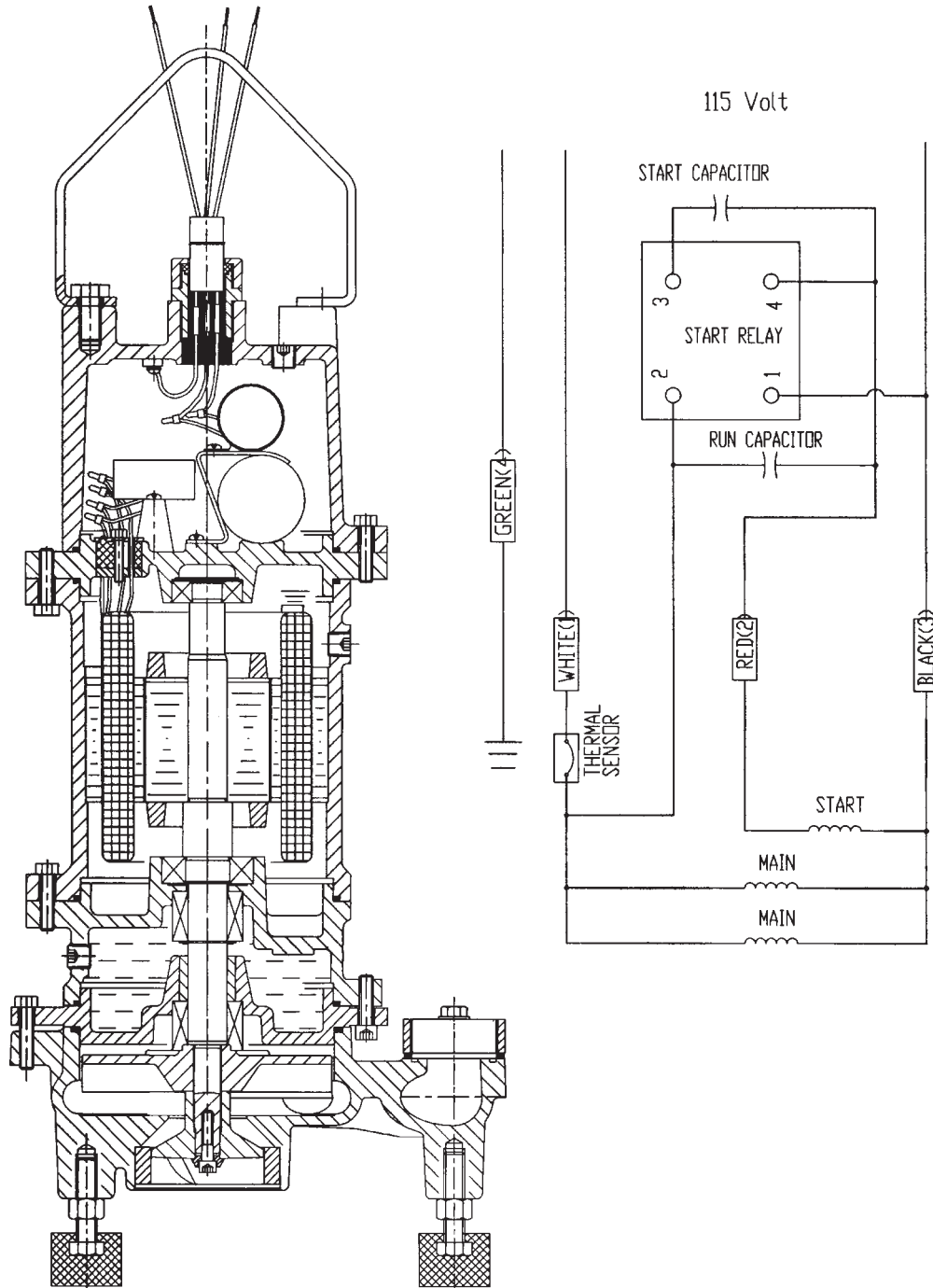

Motor Wiring Diagram

Project:

Model:

Chk'd:

Date:

EB(H)G2-212C

2HP, 208/230V, Single Phase

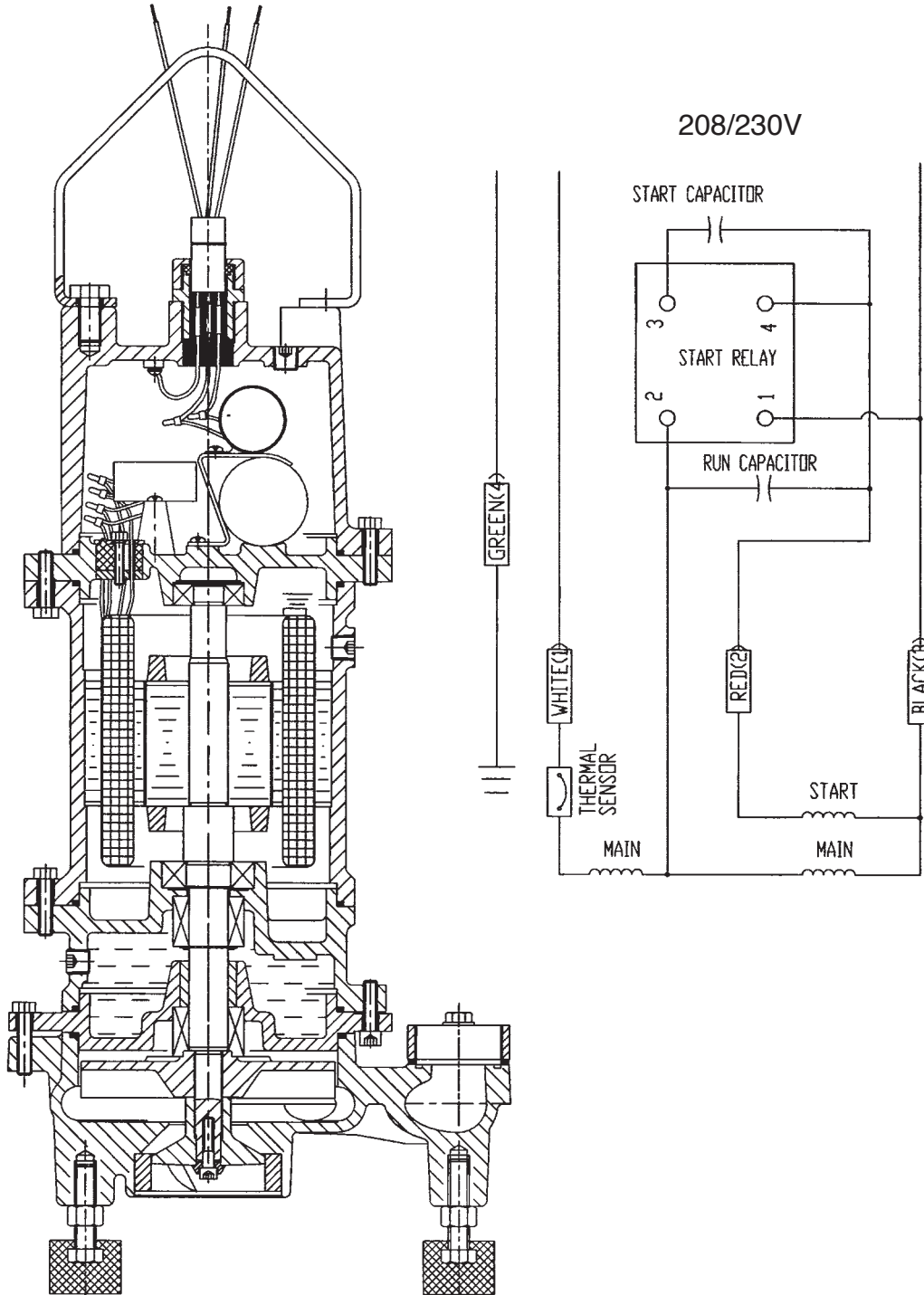

Motor Wiring Diagram

Project: _____ Model: _____ Chk'd: _____ Date: _____

EB(H)G2-21
2HP, 208/230V, Single Phase

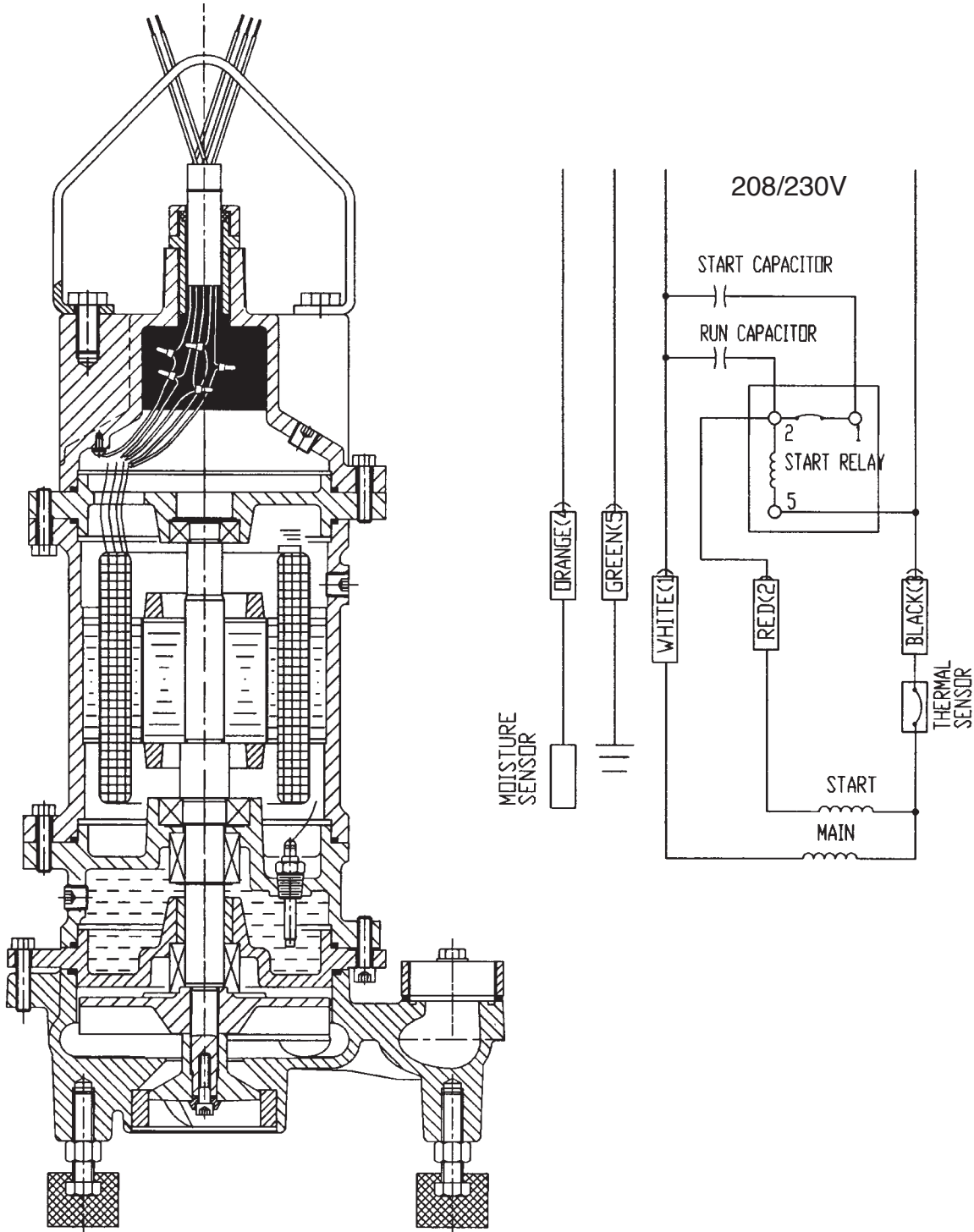

Motor Wiring Diagram

Project:

Model:

Chk'd:

Date:

EB(H)G-31, 51

3, 5HP, 208/230, Single Phase

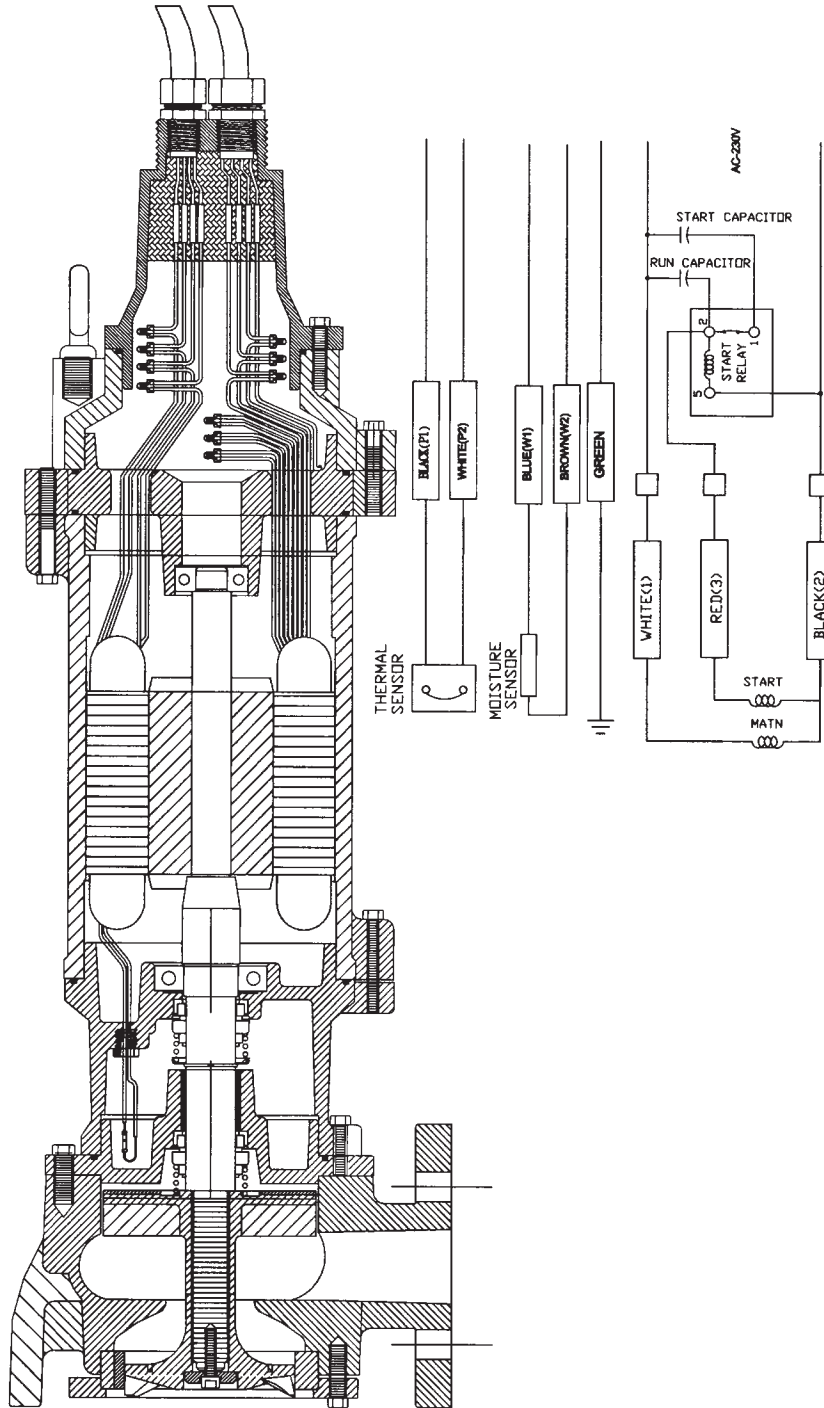

Motor Wiring Diagram

Project: _____ Model: _____ Chk'd: _____ Date: _____

EB(H)G-33, 53, 73, 103
3, 5, 7.5, 10HP, 208/230/460V, Three Phase

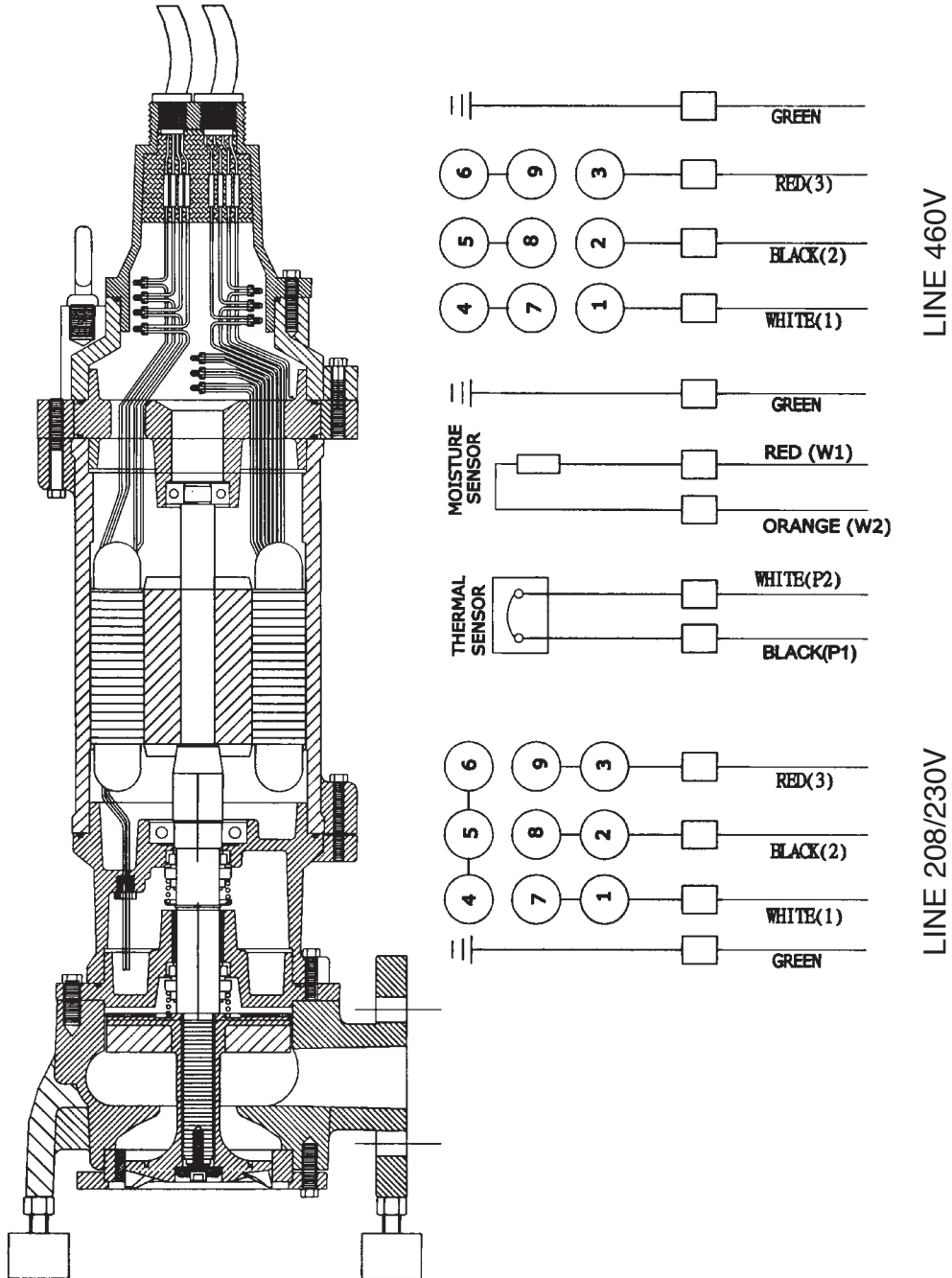

Electrical Data

Project: _____ Model: _____ Chk'd: _____ Date: _____

Model EBG
2 HP, 60Hz, Single Phase, 115V

Name- Plate Rating	Item No.					
	Output (HP)	2				
	Phase	1				
	Poles	2				
	Volts	115				
	Amperes	16.9				
	Speed	3450				
	Insulation Class	H				
Capacitor μ F	Start	200				
	Run	70				
Resistance at 20°C OHMS	Main Coil	1.2				
	Start Current A	48				
	Service Factor	1.59				

Electrical Data

Project: _____ Model: _____ Chk'd: _____ Date: _____

Model EBG, EBHG
2, 3, 5, 7.5 HP, 60Hz, Single Phase, 208/230V

Name- Plate Rating	Item No.					
	Output (HP)	2	3	5	7½	
	Phase	1	1	1	1	
	Poles	2	2	2	2	
	Volts	208 / 230	208 / 230	208 / 230	230	
	Amperes	14 / 12.8	37 / 34	44 / 40	47	
	Speed	3450	3450	3450	3450	
	Insulation Class	H	H	H	H	
Capacitor μ F	Start	150	274 / 324	274 / 324	274 / 324	
	Run	30	30	30	30	
Resistance at 20°C OHMS	Main Coil	1.1	.8	.8	.8	
	Aux. Coil	2.9	.3	.3	.3	
Start Current A		28	72	78	86	
Service Factor		1.59	3.96	2.37	1.4	



Electrical Data

Project: _____ Model: _____ Chk'd: _____ Date: _____

Model EBG, EBHG
2, 3, 5, 7.5 10 HP, 60Hz, Three Phase, 208/230/460V

Name- Plate Rating	Item No.					
	Output (HP)	2	3	5	7½	10
	Phase	3	3	3	3	3
	Poles	2	2	2	2	2
	Volts	208 / 230 / 460	208 / 230 / 460	208 / 230 / 460	208 / 230 / 460	208 / 230 / 460
	Amperes	10 / 9 / 4.5	21 / 18 / 9	29 / 25 / 13	34 / 32 / 16	42 / 40 / 20
	Speed	3450	3450	3450	3450	3450
	Insulation Class	H	H	H	H	H
Resistance at 20°C OHMS	Main Coil	2.0 / 7.6	.6 / 2.0	.6 / 2.0	.6 / 2.0	.8
Start Current A		28	38	56	72	148 / 135 / 75
Service Factor		1.92	3.5	2.1	1.25	1.25

