

Sectional View

Project: _____ Model: _____ Chk'd: _____ Date: _____

Model DSHU
Hot Water Pumps
1/2 to 2HP

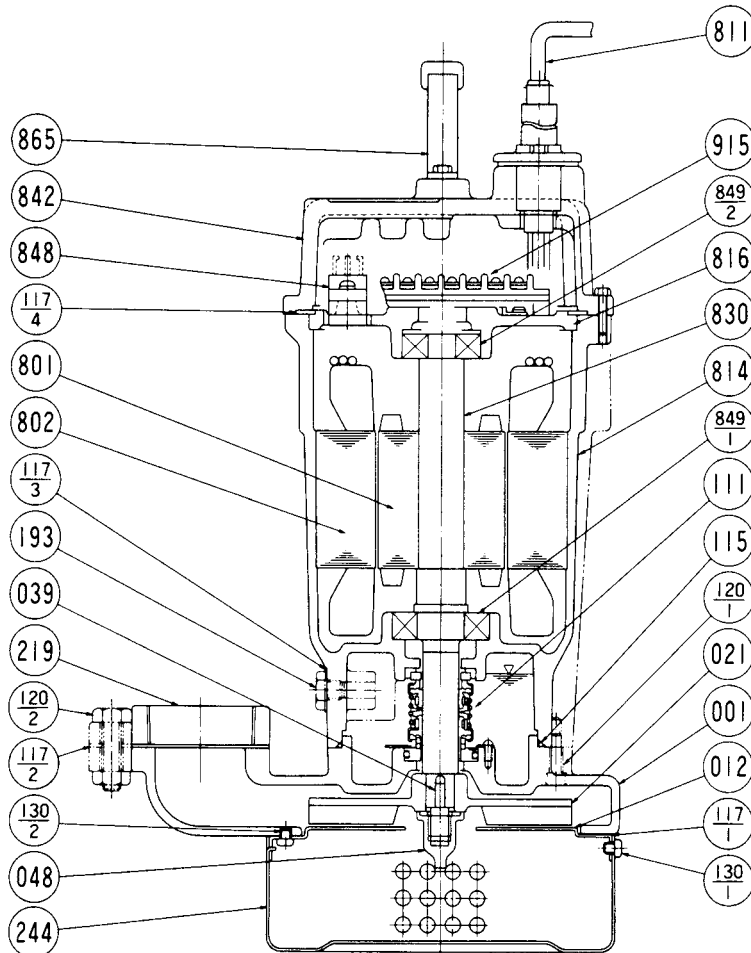

Motors purchased as a complete unit.

PART NO.	PART NAME	MATERIAL	ASTM, AISI CODE	NO. FOR 1 UNIT	PART NO.	PART NAME	MATERIAL	ASTM, AISI CODE	NO. FOR 1 UNIT
001	CASING	CAST IRON	A48 Class 30	1	193	OIL PLUG	BRASS	B36 No. 272	1
012	SUCTION COVER	304 STAINLESS	AISI304	1	219	COMPANION FLANGE	CAST IRON	A48 Class 30	1
†021	IMPELLER	CAST IRON	A48 Class 30	1	244	STRAINER	STEEL	A283 Grade D	1
039	KEY	420 STAINLESS	AISI420	1	801	ROTOR	—		1
048	IMPELLER NUT	BRASS	B36 No. 272	1	802	STATOR	—		1
†111	MECHANICAL SEAL	—		1 SET	†811	SUBMERSIBLE CABLE	—		1
†115	O-RING	RUBBER (NBR)		1	814	MOTOR FRAME	CAST IRON	A48 Class 30	1
†117-1	GASKET	PRESS BOARD		1	816	BRACKET	CAST IRON	A48 Class 30	1
†117-2	GASKET	RUBBER (CR or NBR)		1	830	SHAFT	403 STAINLESS	AISI403	1
†117-3	GASKET			1	842	MOTOR COVER	CAST IRON	A48 Class 30	1
†117-4	GASKET (MODEL DSU)	RUBBER (NBR)		1	848	MOTOR PROTECTOR	—		1
	O-RING (MODEL DSHU)	RUBBER (NBR)		1	†849-1	BALL BEARING	—		1
120-1	BOLT	304 STAINLESS	AISI304	3 or 4	† 849-2	BALL BEARING	—		1
120-2	BOLTS	304 STAINLESS	AISI304	2	865	HANDLE	304 STAINLESS	AISI304	1
130-1	SCREW	304 STAINLESS	AISI304	1	915	EXTERNAL TERMINAL	—		1~2
130-2	SCREW	304 STAINLESS	AISI304	3 or 4					

†: Recommended spare parts.

Sectional View

Project: _____ Model: _____ Chk'd: _____ Date: _____

Model DSU

3 to 10HP

Model DSHU

Hot Water Pumps

3 to 5HP

3 to 5HP

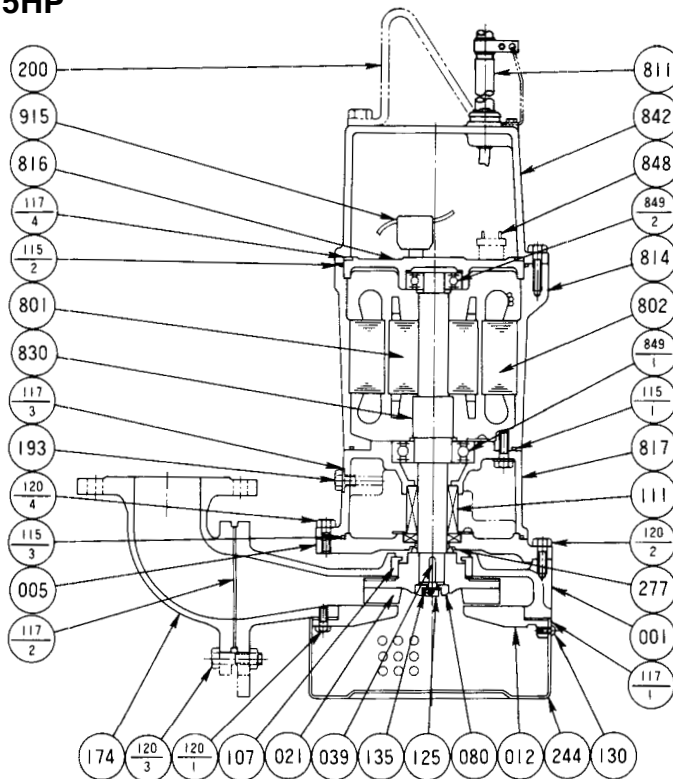

7 1/2, 10HP

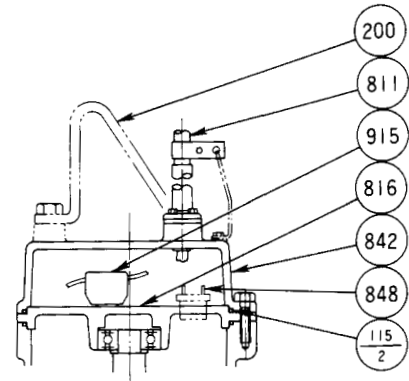

Motors purchased as a complete unit.
 Parts No. 915 is not installed for Model DSHU.
 Parts No. 117-4 is not installed, No. 115-2 is installed 2 pcs. for 7 1/2-10HP.

PART NO.	PART NAME	MATERIAL	ASTM, AISI CODE	NO. FOR 1 UNIT
001	CASING	CAST IRON	A48 Class 30	1
005	INTERMEDIATE CASING	CAST IRON	A48 Class 30	1
012	SUCTION COVER	CAST IRON	A48 Class 30	1
†021	IMPELLER	DUCTILE IRON	A536 GR60-40-18	1
039	KEY	420 STAINLESS	AISI420	1
080	BUSHING	STEEL	A283 Grade D	1
†107	WEARING RING	304 STAINLESS	AISI 304	1
†111	MECHANICAL SEAL	—		1 SET
†115-1	O-RING	RUBBER (NBR)		1
†115-2	O-RING	RUBBER (NBR)		1 or 2
†115-3	O-RING	RUBBER (NBR)		1
†117-1	GASKET	PRESS BOARD		1
†117-2	GASKET			1
†117-3	GASKET			1
†117-4	GASKET	RUBBER (NBR)		1
120-1	BOLT	304 STAINLESS	AISI304	4
120-2	BOLT	304 STAINLESS	AISI304	4
120-3	BOLT	304 STAINLESS	AISI304	4
120-4	BOLT	304 STAINLESS	AISI304	2
125	BOLT	304 STAINLESS	AISI304	1

PART NO.	PART NAME	MATERIAL	ASTM, AISI CODE	NO. FOR 1 UNIT
130	SCREW	304 STAINLESS	AISI304	2
135	WASHER	304 STAINLESS	AISI304	1
174	DISCHARGE ELBOW	CAST IRON	A48 Class 30	1
193	OIL PLUG	BRASS	B36 No. 272	1
200	LIFTING HANGER	STEEL	A283 Grade D	1
244	STRAINER	STEEL	A283 Grade D	1
277	"V" RING	RUBBER (NBR)		1
801	ROTOR	—		1
802	STATOR	—		1
†811	SUBMERSIBLE CABLE	—		1
814	MOTOR FRAME	CAST IRON	A48 Class 30	1
816	BRACKET	CAST IRON	A48 Class 30	1
817	BRACKET	CAST IRON	A48 Class 30	1
830	SHAFT	403 STAINLESS	AISI403	1
842	MOTOR COVER	CAST IRON	A48 Class 30	1
848	MOTOR PROTECTOR	—		1
†849-1	BALL BEARING	—		1
†849-2	BALL BEARING	—		1
915	EXTERNAL TERMINAL			1

†: Recommended spare parts.