

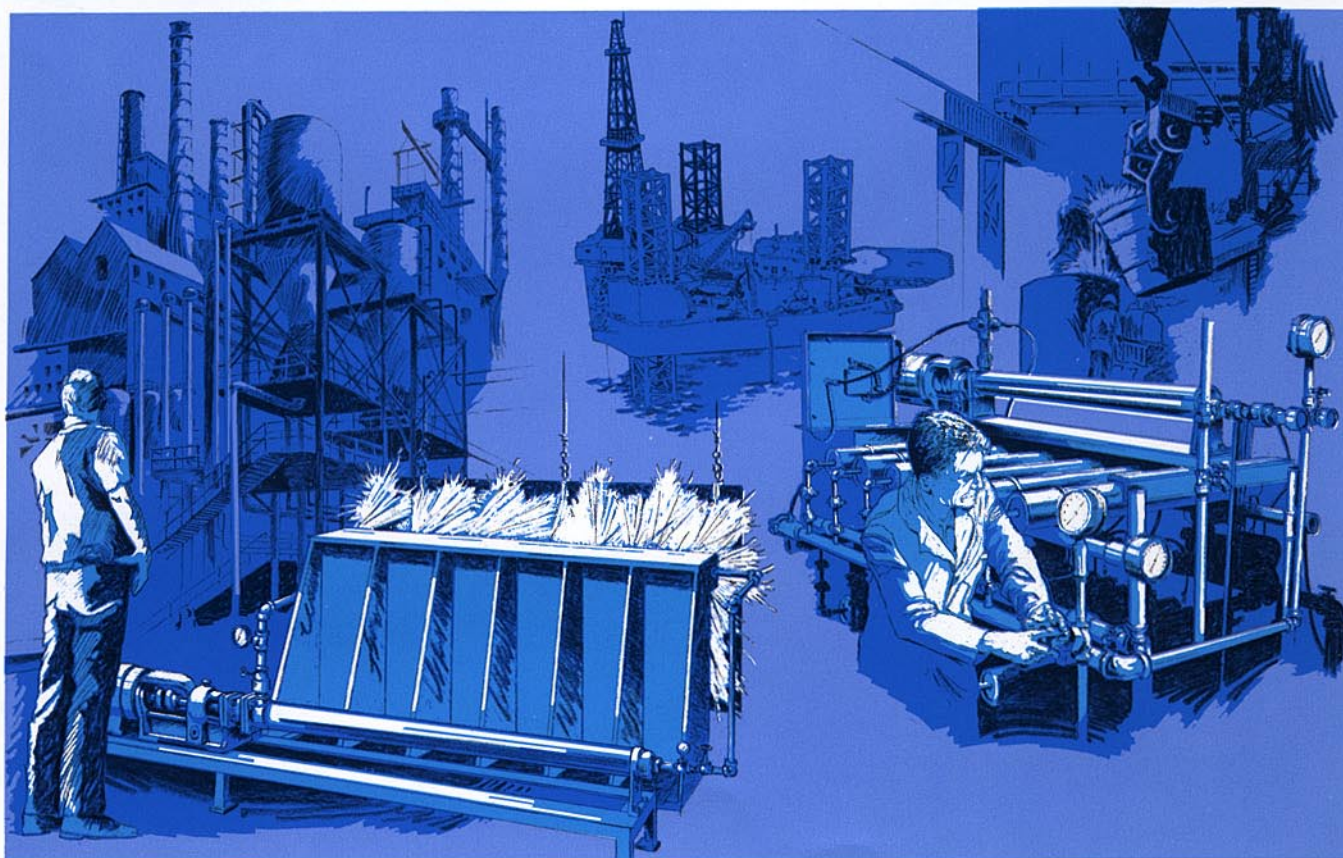

GOULDS PUMPS

Goulds Model 3935 Low Flow – High Head Multi-Stage Pumps

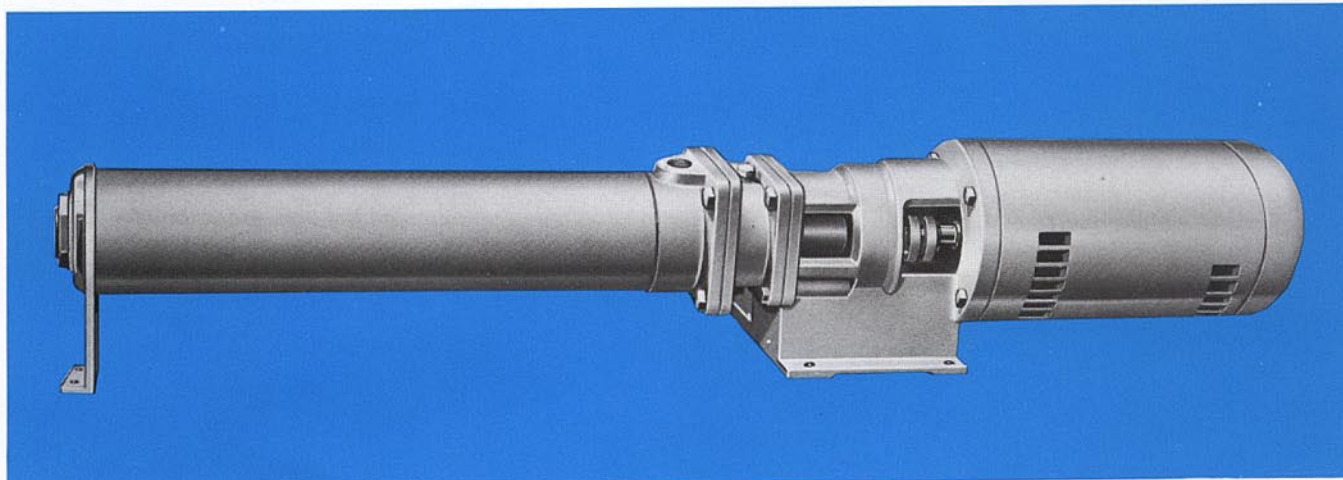

Goulds Pumps



ITT Industries
Engineered for life

Goulds Model 3935

Series BP Multi-Stage Diffuser Type For Wide Range of Low Flow— High Head Services

- Capacities to 125 GPM (28 m³/h)
- Heads to 2600 feet (792 m)
- Temperatures to
400°F (204°C) with cooling
300°F (149°C) without cooling

Services

- Boiler Feed
- Reverse Osmosis
- Petrochemical and Hydrocarbon Services
- Transfer
- Hydraulic Systems
- Descaling
- Process Water
- Spraying Systems
- High Pressure/High Temperature
Cleaning
- All Low Flow Applications Where
Efficiency is Critical

Features

- High Efficiency
- Low NPSH Required
- Quiet Operation — Minimum
Vibration and Low Maintenance
- Few Wearing Parts — Performance
remains essentially the same
throughout pump life.
- Steady Pressure — No accumulators
required to remove pulsation.
- No Relief Valves Required
- Threaded Connections Standard —
Flanged Construction Available
- Easy Flow Regulation — Simple control
systems required.
- Steep performance Curve for Stable
Operation
- Simple Installation
- Low Initial Cost
- Space Saving

Special High Pressure Applications



Boiler Feed

This concept for boiler feed service has been refined by Goulds to give long trouble free operation on small and medium sized boiler feed systems. The low NPSH first stage impellers in most sizes allow the use of economical low settings for deaerators. The single pump shaft with no internal coupling minimizes deflection and assures long seal and shaft life. Wear and corrosion are minimized with ni-resist construction and inherent low velocities are maintained by use of many small diameter impellers having low tip speeds (in lieu of high speed and/or large diameter impellers).

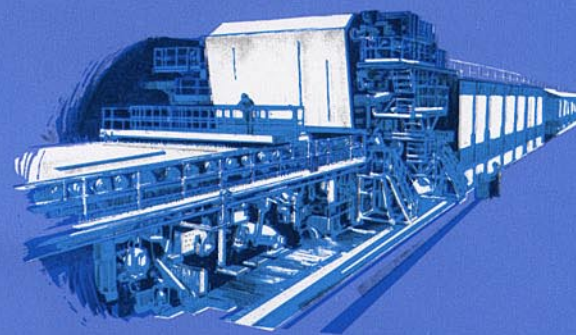

High Pressure Cleaning

The 3935 multi-stage booster is ideally suited where low flow, high pressure and temperature cleaning is required. The minimum design life of 20,000 hours insures long life in this rugged, varying, on-off type service. Pressures to 1000 psi are delivered smoothly, immediately, and consistently at the touch of a button. Inexpensive instrumentation may be installed to effect any control system required.



Model 3935 Series BP Multi-Stage Pumps

Design Features for Wide Range of Low Flow-High Head Services

FOOT SUPPORT

Design allows for thermal expansion on high temperature services.

PRECISION HONED CASING

20-25 RMS finish on casing ID assures bowl alignment and permits easy assembly. Compressed metal-to-metal seal on bowl surfaces and auxiliary o-rings prevent leakage. Barrel type casing with dry buttress thread for high pressure containment.

TAIL BEARING

Provides complete shaft support.

SHAFT

Keyed alloy shaft, one piece throughout pump. No internal coupling.

SEAL HOUSING AND COOLING JACKET

Exclusive chamber for installation of special seal arrangements and/or cooling flush systems. Precision machined to assure alignment between liquid and power end.

SPLINED DRIVE SHAFT

Splined drive shaft and mating pump shaft allow smooth transmission of high horsepower.

MOTOR

Standard NEMA C-face stocked by most motor manufacturers. C-flange mounting assures pump and motor shaft alignment. No coupling alignment required.

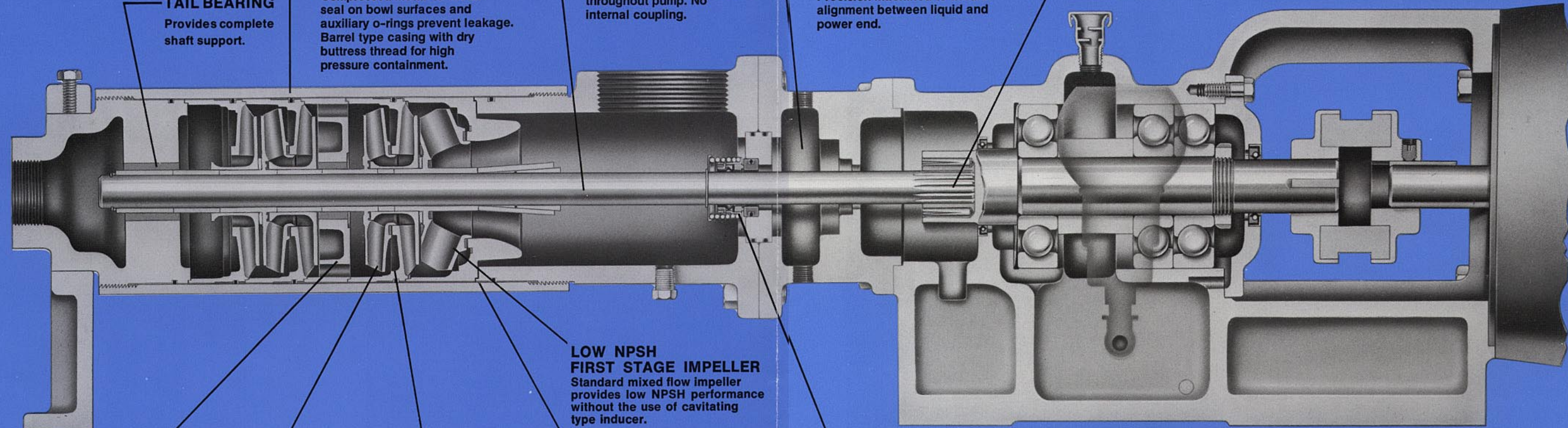

LOW NPSH FIRST STAGE IMPELLER

Standard mixed flow impeller provides low NPSH performance without the use of cavitating type inducer.

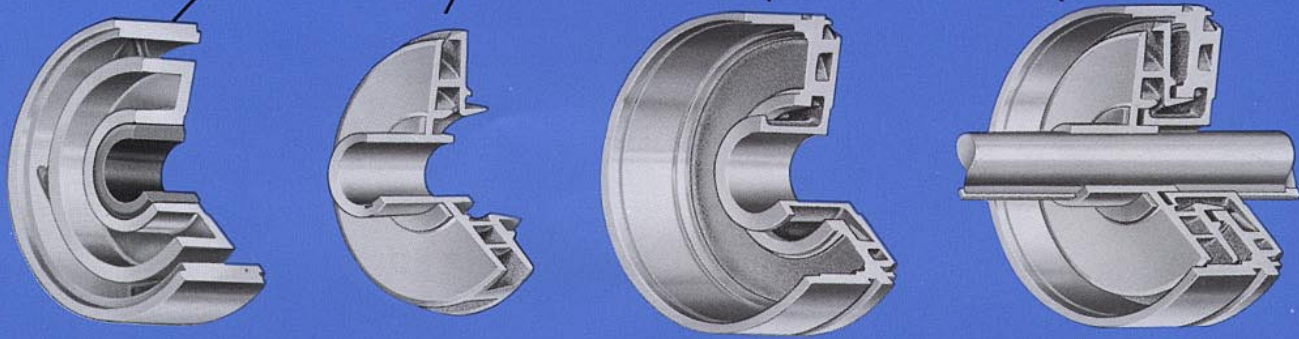

STEADY BEARING

Intermediate carbon shaft bearing self-lubricated by pumpage and lock-fitted for accurate permanent alignment. Bearings spaced at 1 foot (0.3 meters) intervals.

POSITIVE BOWL ALIGNMENT

Rabbit locks provide positive alignment.

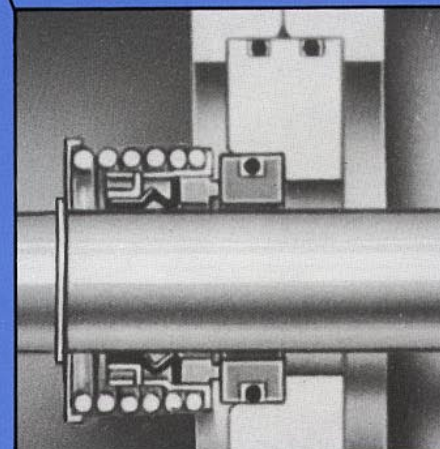

Mechanical Seal

The standard mechanical seal is of single spring design providing positive drive while compensating for seal face wear.

The location of the seal is in direct flow with the pumpage providing the flushing recommended by seal manufacturers for extended service life. The seal is preset on the shaft, requiring no external adjustment or measurement. Metal seal parts are stainless steel. Secondary sealing elements are Viton. Standard seal faces of carbon and ni-resist allow suction pressures to 100 psi. Utilizing carbon and tungsten carbide faces permit suction pressures to 400 psi. Other seals and arrangements are available for special applications.

Parts List and Materials of Construction

Power End

Item No.	Part Name	Material	Grease Lubrication		Oil Lubrication			
			J	S	M	L	X	Y
109	Bearing End Cover	Cast Iron	—	S	—	—	—	—
109A	Bearing End Cover	Cast Iron	—	—	M	L	X	Y
109C	Bearing End Cover Radial	Cast Iron	—	—	—	—	—	Y
112	Ball Bearing, Thrust	Steel	308SZZ	7308PDF	—	—	—	—
112A	Ball Bearing, Thrust	Steel	—	—	7408DT	7408DT	7408DT	7313DT
113	Grease Relief Fitting	Steel/Cad Plate	—	S	—	—	—	—
113A	Breather	Steel/Zinc Plate	—	—	M	L	X	Y
123	Deflector (Not Shown)	Lam Plastic	—	—	—	—	—	Y
131	Pump Foot (BP20 Only)	Cast Iron	J	S	M	L	X	—
131	Pump Foot (Except BP20)	Cast Iron	—	S	M	L	X	Y
136	Bearing Lock Nut	Steel	—	S	M	L	X	Y
168A	Ball Bearing Coupling End	Steel	—	—	408S	408S	408S	313S
193	Grease Fitting	Steel/Zinc Plate	—	S	—	—	—	—
228	Frame—Grease Lube	Cast Iron	J	S	—	—	—	—
228A	Frame—Oil Lube	Cast Iron	—	—	M	L	X	Y
232	Coupling Hub—Motor	Die Metal	J	S	M	L	X	Y
233	Coupling Hub—Pump	Die Metal	J	S	M	L	X	Y
235	Coupling Sleeve	Rubber **	J	S	M	L	X	Y
251	Sight Oiler	White Metal/Glass	—	—	M	L	X	Y
332	Grease Seal—Bearing Cover	Buna-N	—	S	—	—	—	—
332A	Oil Seal—Bearing Cover	Buna-N	—	—	M	L	X	Y
333	Grease Seal—Frame	Buna-N	—	S	—	—	—	—
333D	Oil Seal—Frame	Buna-N	—	—	M	L	X	Y
360	Gasket End Cover	Vellumoid	—	S	M	L	X	Y
361E	Retaining Ring—Bearing	Steel	J	—	—	—	—	—
370B	H Cap Screw, Frame to Adapter (Not Shown)	Steel	—	—	—	—	—	▲Y
370N	H Cap Screw—End Cover	Steel	—	S	M	L	X	Y
371	H Cap Screw—Frame to Motor	Steel	J	S	M	L	X	Y
371U	H Cap Screw—Pump Foot Retaining	Steel	J	S	M	L	X	Y
380	Stub Shaft	Steel	J	S	M	L	X	Y
382	Bearing Lock Washer	Steel	—	—	—	—	—	Y
389	Motor Adapter (Not Shown)	Cast Iron	—	—	—	—	—	▲Y
400	Coupling Key	Steel	J	S	M	L	X	Y
443	Bearing Spacer	Steel	—	—	M	L	X	Y
529	Wave Washer	Steel	—	S	M	L	X	Y

Liquid End

Item No.	Part Name	Material
100	Casing	Carbon Steel
101	Impeller	NI-Resist Type 1
108	Casing Adapter	NI-Resist Type 2
122	Shaft	K-Monel
150	Diffuser	NI-Resist Type 1
150A	Spacer Blank (Not Shown)	NI-Resist Type 2
151	Suction Diffuser	NI-Resist Type 2
152	Discharge Head	NI-Resist Type 2
157	Spacer Sleeve	316 SS
157B	Intermed. Brg. Shaft Sleeve	316 SS
157C	1st Stage Shaft Sleeve	316 SS
158	Stationary Seat Mount	NI-Resist Type 2
159	Seal Housing	NI-Resist Type 2
178	Impeller Key (Not Shown)	Monel Alloy 400
188*	Cooling Jacket (Not Shown)	NI-Resist Type 2
201‡	Impeller, First Stage	NI-Resist Type 1
260	Intermediate Bearing	NI-Resist Type 1 Carbon Insert
331	Shim	304 SS
361	Retaining Ring, Shaft	303 SS
361D*	Retaining Ring, Mech Seal	303 SS
370V	H Cap Screw-Adapter to Seal Housing	Steel
371L	H Cap Screw-Seal Housing to Frame	Steel
383A	Rotary Element	18-8 SS-Viton
383B*	Stationary Seat (XP171)	NI-Resist & Viton
383B	Stationary Seat (XP1D1)	Carbide & Viton
408A	Pipe Plug-Drain	Brass
412J*	O-Ring Cooling Jacket (Not Shown)	Viton
412K	O-Ring Casing	Viton
412L	O-Ring Stationary Seat Mount	Viton
473*	Restricting Bushing (Cooling Jacket) (Not Shown)	Carbon
522	Drive Collar	316 SS
524	Split Collet	316 SS
546	Washer-Back	Glass-Moly-Teflon

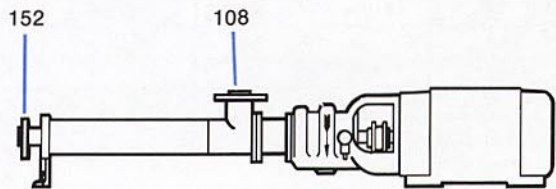

Optional Flanged Construction

Item No.	Part Name	Material
108	Casing Adapter	Cast Carbon Steel
152	Discharge Head	Cast Carbon Steel

*Optional ▲-For 444TSC and 445TSC Motors Only ‡-BP40, 70 & 100 Only **Steel on Y Frame

Pressure / Temperature Capability

Pressure	Working Pressure	1500 PSI Maximum (105 kg/cm ²)	
	Suction Pressure	400 PSI Maximum (28 kg/cm ²)	
Temperature	W/O Seal Housing Cooling	J and S Frames (Grease Lube)	to 250°F (120°C)
		L, M, X & Y Frames (Oil Lube)	to 300°F (149°C)
	W/Seal Housing Cooling	All Frames	to 400°F (204°C)

Sectional View Model 3935

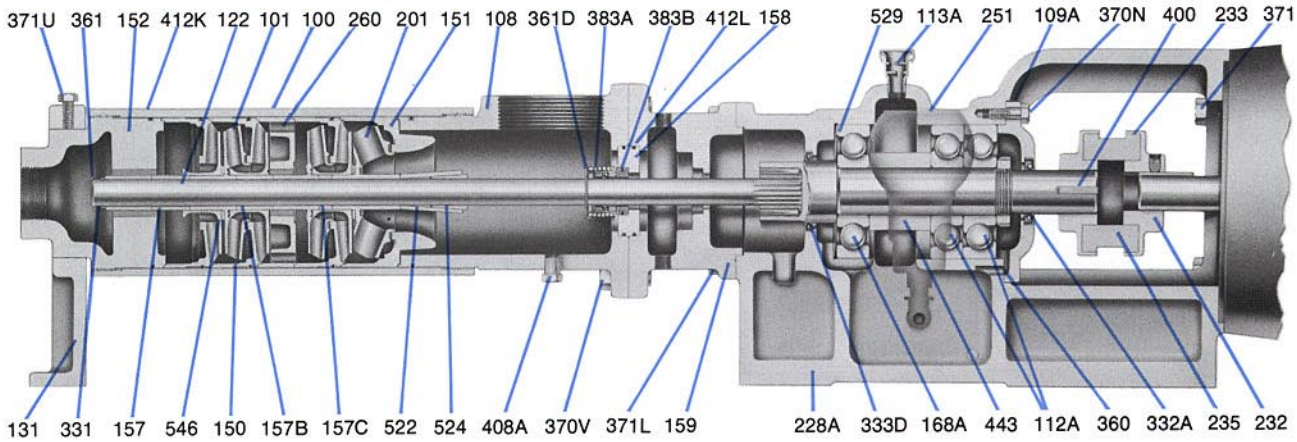

Bearing Frames

J Frame

A greased-for-life medium duty Conrad bearing carries thrust loads developed by the low pressure BP20 series pumps. The maximum HP motor able to be mounted on the J frame is the 3 HP ODP.

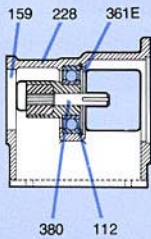

S Frame

Two angular contact bearings mounted face-to-face carry low to medium duty thrust loads in this regreaseable bearing frame. Motors from 3 HP TEFC to 25 HP ODP can be mounted on this bearing frame.

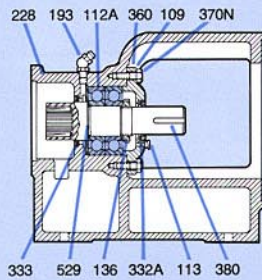

M Frame

A single angular contact bearing carries medium to heavy thrust loads and provides oil lubrication for pumps requiring motors from 3 HP TEFC to 25 HP ODP.

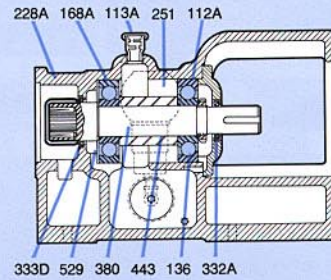

L & X Frames

The oil lubricated L frame provides high thrust capability as encountered in high discharge pressure applications with tandem mounting of angular contact bearings. The L frame takes the same motor sizes as the S and M frames. On the X frame, an angular contact, tandem bearing arrangement identical to the L frame carries high thrust loads and extends motor capability from 25 HP TEFC to 40 HP ODP.

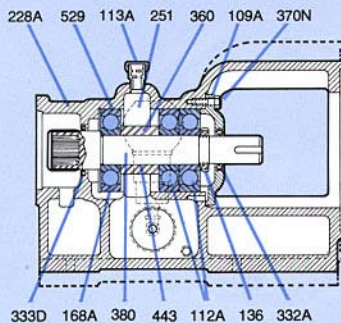

Y Frame

Foot mounted industrial motors from 40 HP TEFC through 150 HP TEFC are mounted on the Y frame. The inherent high thrusts encountered in high pressure applications are carried by an angular contact tandem bearing arrangement. Pump mounting is accomplished by utilizing the motor feet rather than integral mounting pads on the bearing frame.

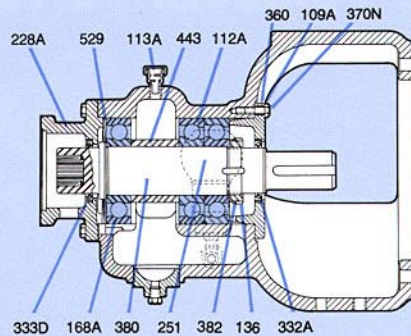

3500 R.P.M. Hydraulic Coverage

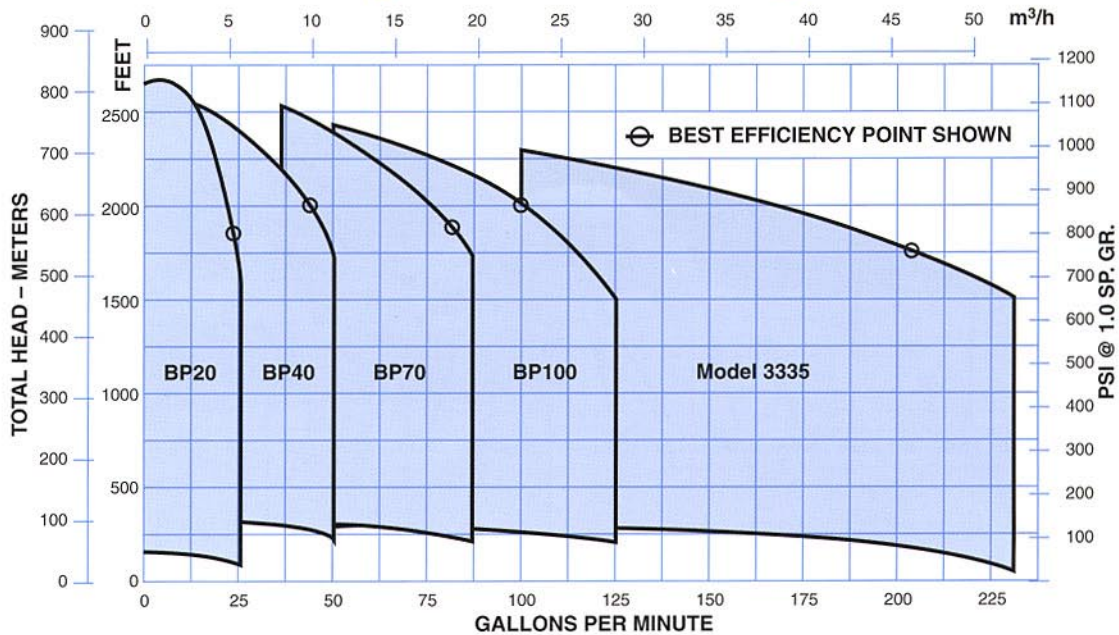

Maximum Sealing Flexibility

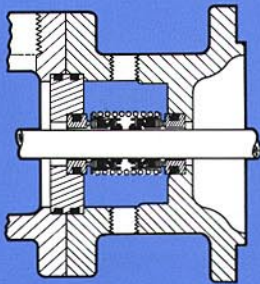

Double Unbalanced Seal

Used where it is desirable to keep mechanical seal out of pumpage. This arrangement can also be used on high vacuum service where sealing is essential.

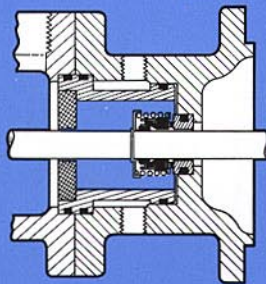

Cooling Chamber With Close Fitting Carbon Bushing

Used on hot services where pumping temperature exceeds the allowable limits of the mechanical seal.

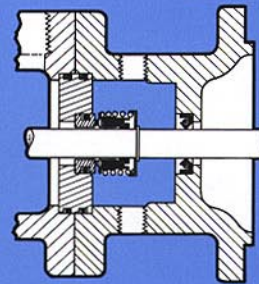

Low Pressure Cooling and/or Flush

Used mostly on high temperature heat transfer fluids operating at low suction pressures for very effective cooling.

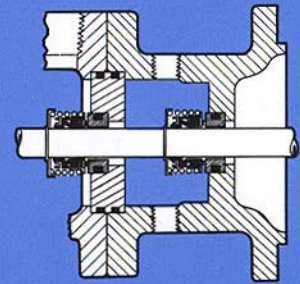

Tandem Seals

Used on toxic and highly flammable services with oil or other compatible fluid buffer.

Quiet – Smooth Performance

The centrifugal characteristics of Goulds Model 3935 assure quiet, smooth, low maintenance operation. High pitched noise inherent in high speed single stage designs and piston noise associated with reciprocating pumps are alleviated with the multi-stage diffuser design of the Model 3935. Therefore, the quiet, smooth-running 3935 easily meets the sound and vibration level requirements demanded by today's ecology minded industries.

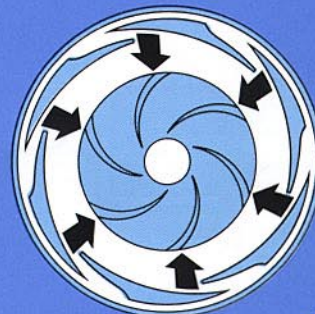

Radial Load On Impeller Is Equal and Balanced

Dimensions Model 3935

All dimensions in inches. Not to be used for construction.

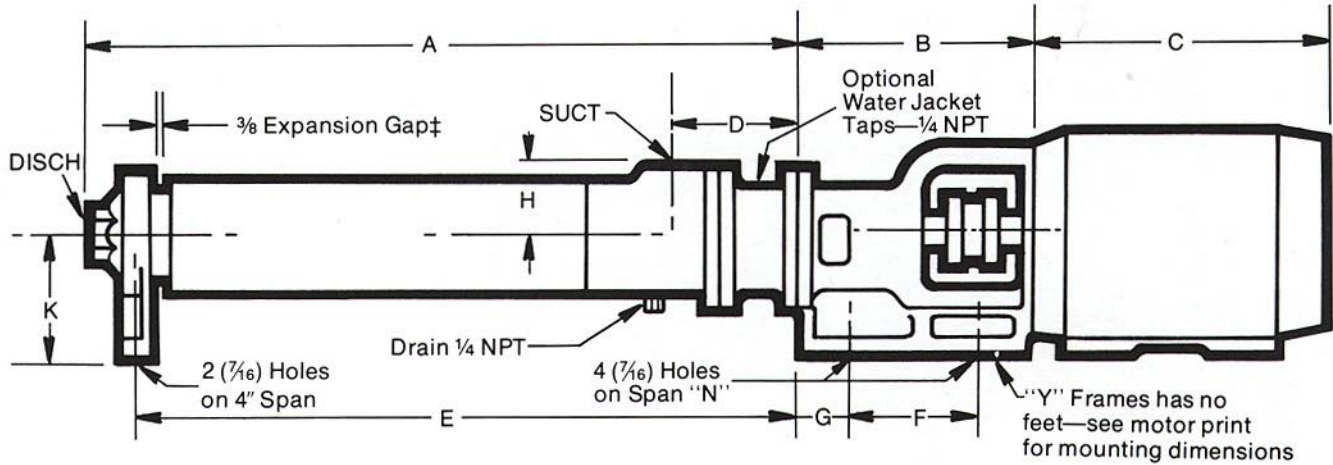

MAXIMUM & MINIMUM DIMENSIONS DETERMINED PUMP*

Pump		A	C	D	E	H	K	Suct.	Disch.
BP20	Min	16 ⁵ / ₁₆	11	3 ⁷ / ₈	15 ⁵ / ₁₆	2 ³ / ₄	4 ¹ / ₂	1 ¹ / ₂ " NPT	1" NPT
	Max	101	18 ³ / ₄	4 ¹⁵ / ₁₆	100 ¹ / ₄		7		
BP40	Min	23 ³ / ₁₆	11 ⁷ / ₁₆	6	22 ² / ₁₆	3 ¹ / ₁₆	6 ¹ / ₄	3" NPT	1 ¹ / ₂ " NPT
	Max	66 ¹⁵ / ₁₆	22 ¹ / ₄	6	66 ⁵ / ₁₆		11		
BP70	Min	24 ¹⁵ / ₁₆	13 ¹ / ₁₆	6	24 ⁵ / ₁₆	3 ¹ / ₁₆	6 ¹ / ₄	3" NPT	1 ¹ / ₂ " NPT
	Max	84 ³ / ₄	22 ¹ / ₄	6	84 ¹ / ₈		11		
BP100	Min	26 ⁷ / ₁₆	13 ¹ / ₁₆	6	25 ¹ / ₁₆	3 ¹ / ₁₆	6 ¹ / ₄	3" NPT	1 ¹ / ₂ " NPT
	Max	98 ¹ / ₄	26 ⁵ / ₈	6	97 ⁵ / ₈		11		

* Pump length and number of stages varies with developed head at best efficiency point

DIMENSIONS DETERMINED BY FRAME

Frame	B	F	G	N
J	7 ¹ / ₂	5 ¹ / ₄	1 ¹ / ₈	5
S	12 ¹ / ₈	8 ⁵ / ₈	1 ³ / ₄	4
M & L	15 ⁷ / ₈	8 ⁵ / ₈	1 ³ / ₄	4
X	15 ⁷ / ₈	8 ⁵ / ₈	1 ³ / ₄	4
Y	19 ⁵ / ₈	NA	NA	NA

‡ = Gap is 1/8" on J frame only

NOTES: All 'C' dimensions are approximate for ODP motors.

All 'A' dimensions based on ambient temperature.

Flanged suction and discharge connections available. Flanges are ANSI 600 lb. standard (1/4 raised face) and will accept either 300 lb. or 600 lb. companion flanges (not illustrated above)

visit our website at www.gouldspumps.com

Goulds Pumps

