

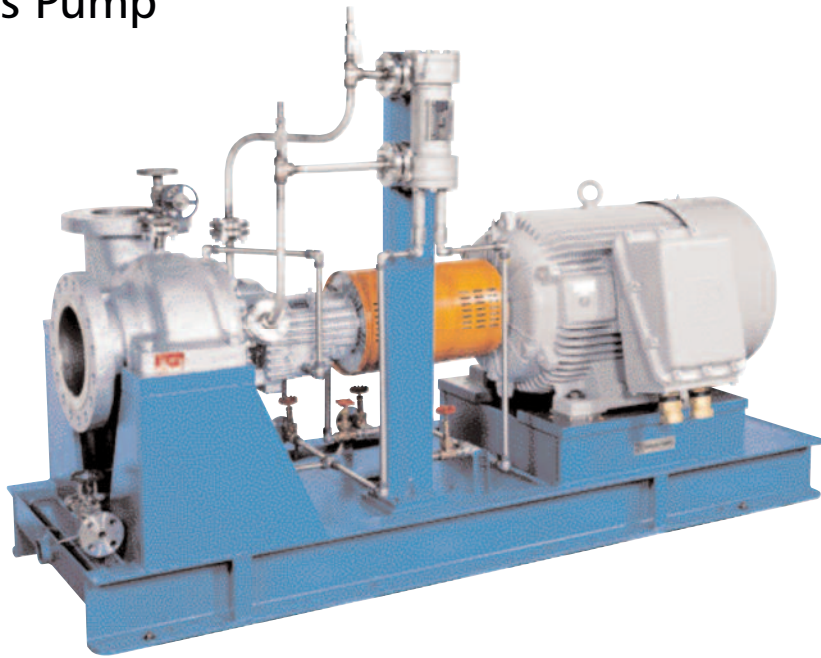

Goulds Pumps

Goulds 3700

ISO 13709 2nd Edition/API 610 11th Edition
Single-Stage, Overhung (API OH-2)
Process Pump



Engineered for life

A Leader in API Engineered Pump Package Solutions...

Proven API Leadership

ITT Goulds Pumps is a proven leader in API Pumps

- ◆ Over 20,000 units installed
 - Over 17,000 OH2/OH3's
 - Over 3,000 BB1/BB2/BB3 pumps
- ◆ 40+ years of API expertise
- ◆ Participating member on API 610 and API 682 committees

Family of API Pumps

ITT Goulds Pumps has a family of proven API pumps

- ◆ Overhung pumps
- ◆ Single and two-stage between-bearing
- ◆ Multistage between-bearing pumps— axially split
- ◆ Barrel Multi-Stage pumps
- ◆ Vertical, double casing pumps
- ◆ Specialty pumps

Global Coverage

ITT Goulds Pumps has the global coverage needed to serve multi-national companies in any region.

Industry Leading Hydraulic Coverage

- ◆ We offer extensive coverage to meet your process needs.
- ◆ Better hydraulic fits can mean improved efficiency and long-term reliability and parts life.

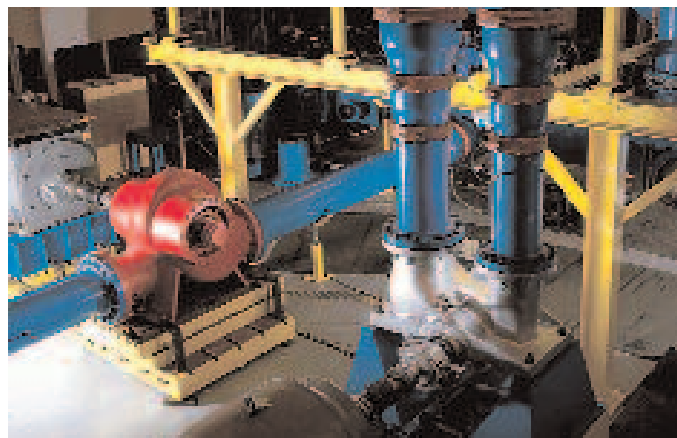

6000 HP / 4600 kW Testing Capability

- ◆ Our expanded test facility can test your pump in the most demanding of conditions.
- ◆ Testing at rated speeds is critical to assess the impact of dynamic conditions including vibration.

API Engineering Expertise

- ◆ We are experts in packaging engineered pumps that meet your demanding applications — with true conformance to the latest API specifications.
- ◆ We have extensive experience in nearly every type of driver, bearing, seal, piping configuration, nozzle configuration, flange and baseplate designs to meet your application needs.
- ◆ ITT is a world leader in technology and engineering including hydraulics, materials science, mechanical design, and fluid dynamics.

Broad Applications

- ◆ Petroleum refining, production, and distribution
- ◆ Petrochemical and demanding chemical processing
- ◆ High temperature applications including boiler circulation
- ◆ General industrial requiring high temperature or high pressures

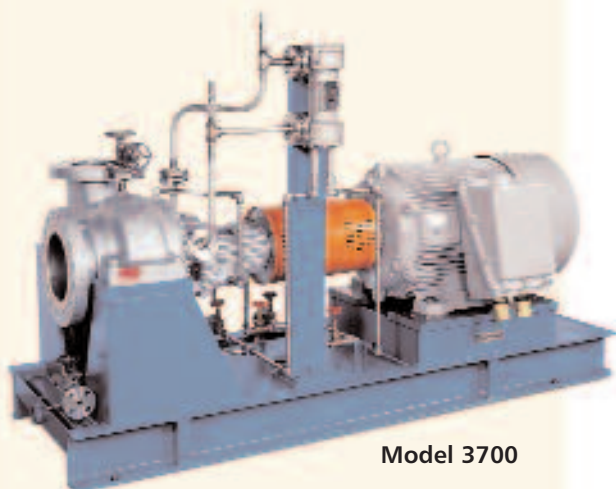

Model 3700

End Suction API-610/ISO 13709 Process Pump

- ◆ Designed for optimum reliability
- ◆ State-of-the-art mechanical design features
- ◆ 48 casing sizes—choice of impellers with most casings.

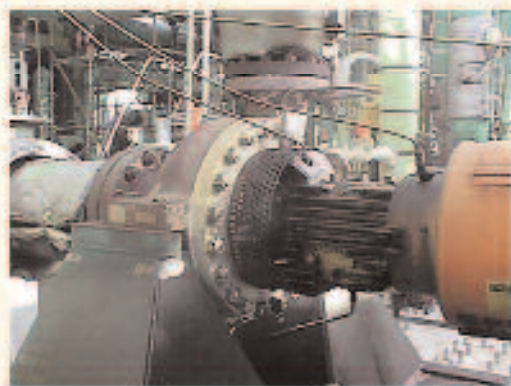

Model 3700 on high temperature
service at a U.S. Gulf Coast refinery.



High-pressure (1100 psi) customized pump.

Goulds 3700

High Temperature and Pressure Process Pumps that Meet or Exceed ISO 13709 and API 610 11th Edition

Safety, reliability, and versatility are the key words for our end-suction, centerline mounted, overhung (OH-2) API 610 process pump.

Safety and Reliability

We provide engineered solutions with true conformance to the latest API specifications including the stringent emissions containment per API 682.

The result is a safe and rugged overhung API process pump designed for a 20-year life.

Versatility

- ◆ Capacity to 8500 GPM (1930 m³/h)
- ◆ Total Dynamic Head to 1200 feet (360 m)
- ◆ Temperature to 800°F (425°C)
- ◆ Pressure to 870 PSIG (60 Bar)

Materials: Available in a wide range of materials including all API 610 constructions and custom application needs.

Engineered Hydraulics: An industry leading 99 hydraulic combinations to better match your process for efficiency and reliability. Custom hydraulics are available.

Engineered Packaging with a wide range of drivers, seals, piping, nozzle configurations, flanges, baseplates, and QC testing.

Services

Column Reflux	Hot Oil	Stabilizer Overhead
Column Bottoms	Reboiler	Stripper Overhead
Column Charge	Reactor Feed	Heat Transfer
Injection	Tower Bottoms	Slop Gas Oil
Fuel Blending	Heavy Gas Oil	Scrubber Circulation
Offsite Hydrocarbon Transfer		

Standard Features for Optimum Reliability

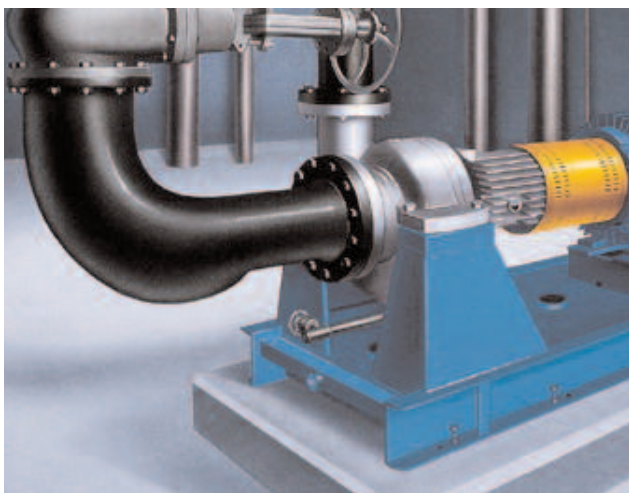

Proven API-610 Nozzle Load Design

Rugged casing and baseplate/pedestal support system provides flange loading capability exceeding API-610/ISO 13709 requirements without the use of a bearing frame support.

Full Flange Rating Pressure Capability

All pumps designed to operate at 2 pole running speeds have casings designed for the full pressure capability of a 300 RF flange.

Spiral Wound Casing Gasket

Casing to cover joint sealed with a spiral wound, controlled compression gasket required by API-610. Provides positive sealing up to the maximum design pressure and temperature.

Goulds 3700 LF Designed for Low Flow Services

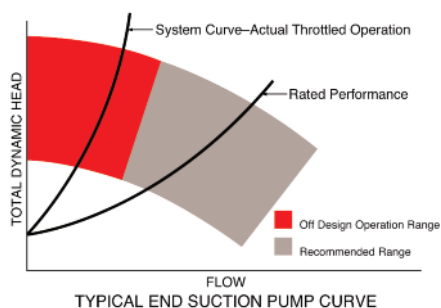

Not All Pumps are Designed for Low Flows

Many users throttle pumps to attain low flow rates - yet create bearing and seal issues. The traditional enclosed impeller passage ways would be too small to properly manufacture at these low flow rates.

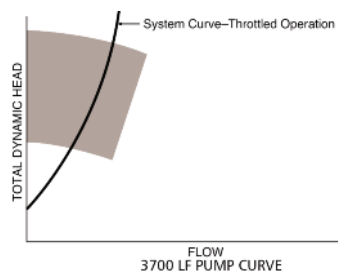

3700 LF Low Flow Solution

The 3700 LF open radial vane impeller eliminates these enclosed impeller limitations. The unique circular volute casing eliminates competitor diffusers thus reducing the pump size, footprint and lifetime costs.

Improved Bearing Environment

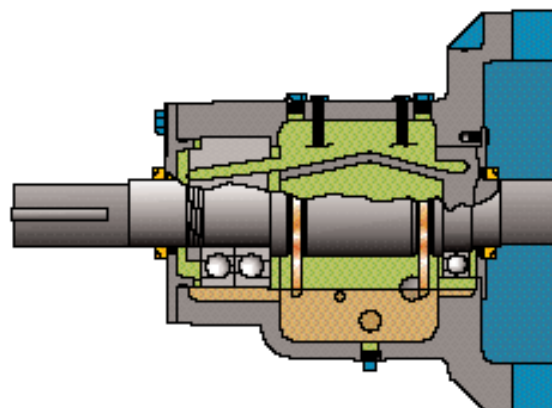
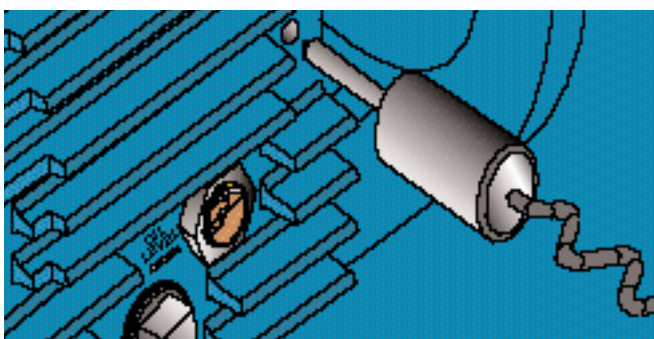

- Bearing frame fins provide optimum heat dissipation.
- Condition monitoring sites allow easy and consistent monitoring of temperature and vibration. Provision for instrumentation mounting per API-670 available.
- Large oil sight glass allows viewing condition and level of oil, critical for bearing life.

- Extra large oil sump provides cooler running bearings.
- Proven channeled oil lubrication system assures flow-thru of cooled oil to thrust and radial bearings.
- Standard dual oil rings, positively located, provide oil flow to channeled oil lubrication system and prevent oil foaming.

Optional Features for Application Flexibility

Goulds offers users a range of options to meet specific plant and process requirements.

High Temperature Capability *For high temperature applications, these options are available.*

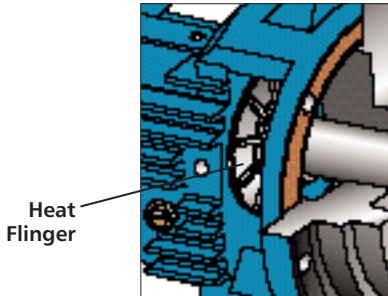

Heat Flinger

Heat flinger dissipates shaft-conducted heat and circulates air to reduce heat build-up.

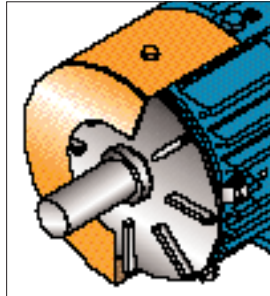

Air Cooling

High capacity fan and shroud mounted on power end effectively reduce bearing frame temperature for cooler running bearings without using cooling water.

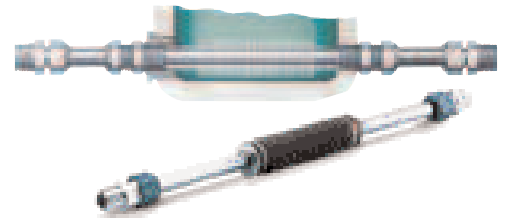

Water Cooling

Finned cooler for maintaining oil/bearing temperature. Corrosion resistant material.

Lubrication Flexibility

Oil Mist Lubrication System

Connections for pure or purge oil mist lubrication can be provided for immediate use or future requirements.

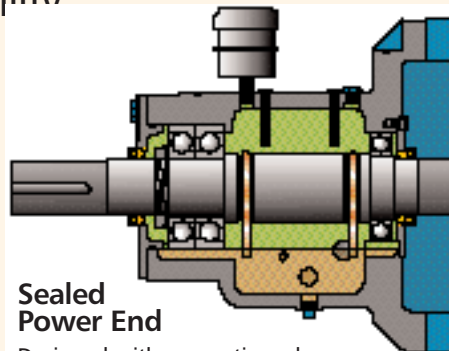

Sealed Power End

Designed with magnetic end face seals and expansion chamber to prevent contaminants from entering the power end.

Lubricant Sight Glass and Sampling Bottle

For visual inspection and sampling of oil.

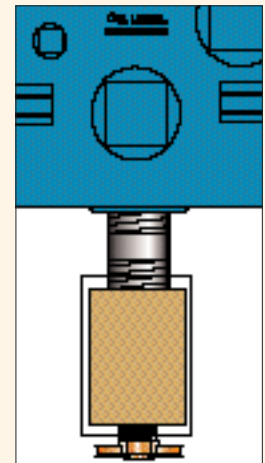

Other Options

Extra Wide Baseplate

Provided for seal systems with auxiliary components to improve maintenance access.

Heavy Duty Pedestal

Unique trapezoidal design provides superior resistance to deflections from flange loads.

Top Suction Nozzle

This option reduces space requirements and installation costs for unique applications.

Inducer Option

Under certain conditions, reduction in NPHSR can be provided with an axial flow inducer.

Coke Crusher Option

Allows coke particles to be easily pumped by crushing coke with a cutter screw.

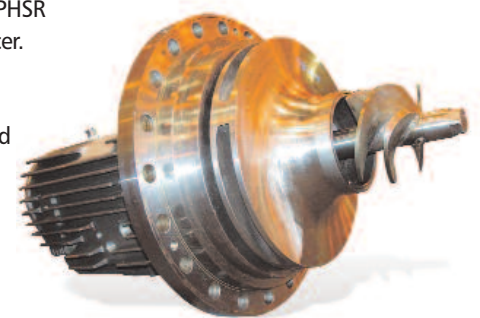

Inducer Option



Model 3700 ISO 13709/API-610 Process Pumps

Design Features for Wide Range of High Temperature/ High Pressure Services

TANGENTIAL DISCHARGE

Design maximizes hydraulic efficiency.

CONFINED CONTROLLED COMPRESSION GASKET

Spiral wound gasket assures positive sealing with no chance of misalignment.

RENEWABLE WEAR RINGS STANDARD ALL SIZES

Positively locked and set screwed. Front and rear rings control seal chamber flows and pressures. Optional non-metallic rings for improved efficiency.

IMPELLER

Multiple closed impellers for most casings to meet specific hydraulic requirements. Balanced to stringent requirements of API-610/ISO 13709. **Low flow pumps utilize an open impeller design.**

NOZZLE LOAD CAPABILITY

Casing/baseplate design optimized to exceed toughest API/ISO nozzle load criteria.

FABRICATED BASEPLATE

Enlarged drain connection to prevent buildup of debris. All joints are continuously welded. Extra width sizes available to ease maintenance of seal systems.

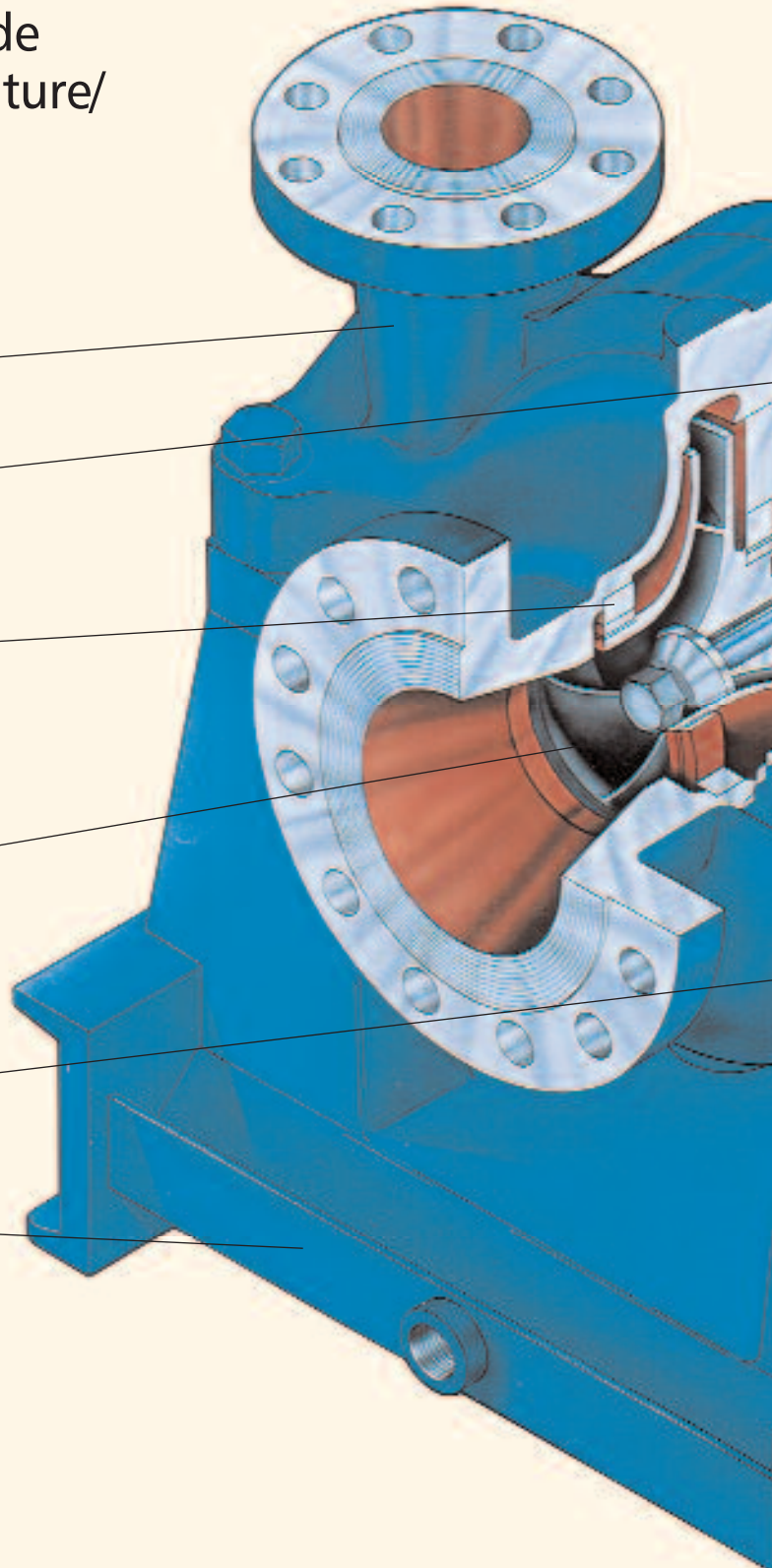

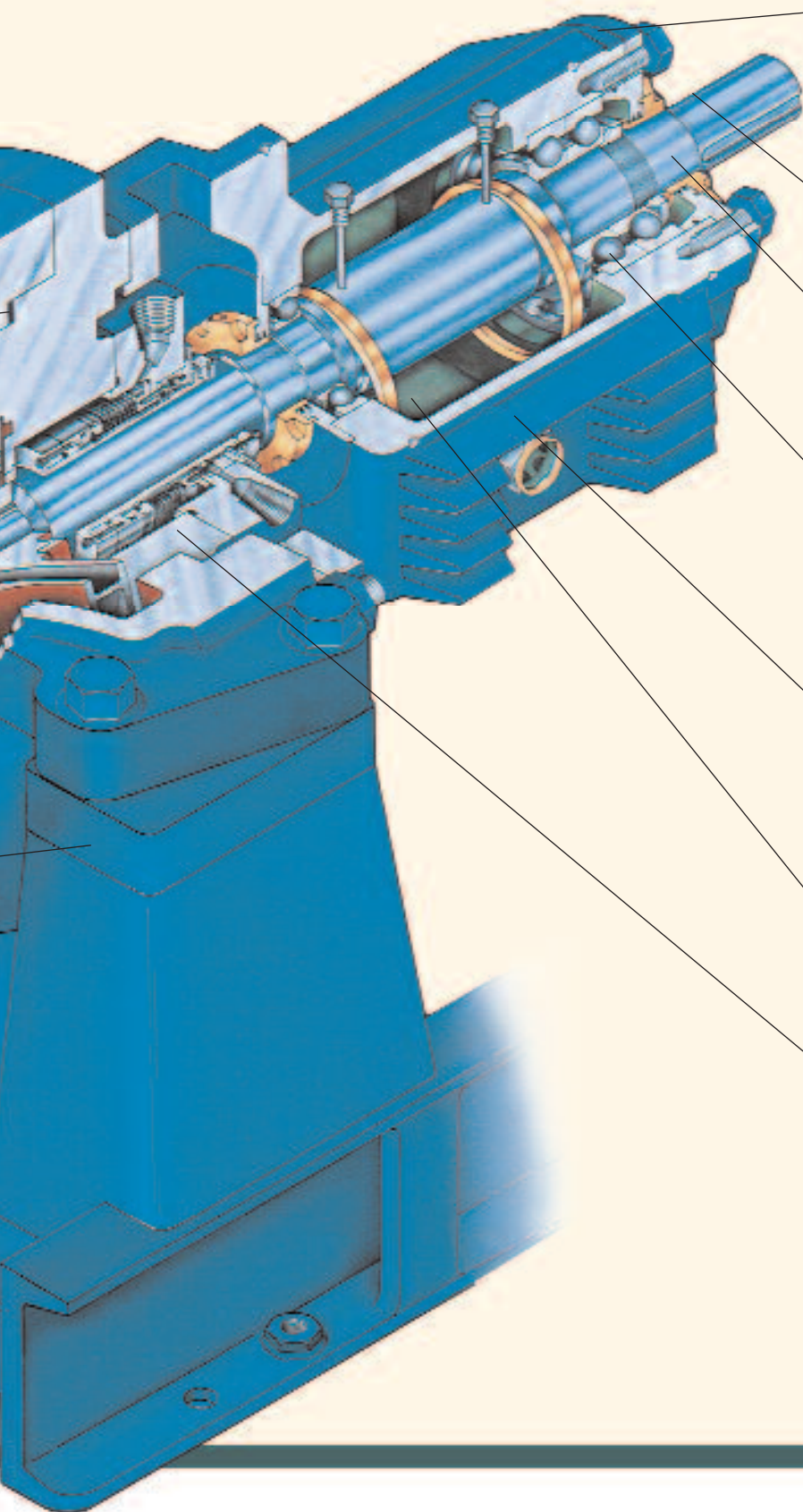

BONUS INTERCHANGEABILITY

Bearing frame, seal chamber, bearings, shaft, mechanical seal, impeller and wear rings completely interchangeable with Goulds Model 3910 bearing frame in-line process pumps. Entire back pull-out assembly interchangeable with Model 3710.

RIGID, HEAVY DUTY SHAFT

Minimizes shaft deflection, maximizes bearing and mechanical seal life.

LABYRINTH OIL SEALS

Labyrinth seal design prevents oil from leaking out and contaminants from intruding. Made from non-sparking metal.

BEARINGS

Duplex 40° angular contact thrust bearings and deep-groove (Conrad) radial bearings sized for minimum three (3) year bearing life under most severe operating conditions. Exceeds API-610/ISO 13709 requirements.

HEAVY DUTY BEARING FRAME

Piloted and metal-to-metal fits assure runouts and concentricities well within limits specified in API-610/ISO 13709. Large oil sump capacity. Cast fins enhance cooling.

LUBRICATION SYSTEM

Proven, engineered ring-oiled flow-thru bearing lubrication optimizes MTBPM.

API 682 SEAL CHAMBER

Enlarged seal chamber fully conforms to API-610/ISO 13709 standards. Accepts wide range of API 682/ISO 21049 cartridge mechanical seals. Renewable throat bushing standard for controlled seal chamber environment.

Sectional View

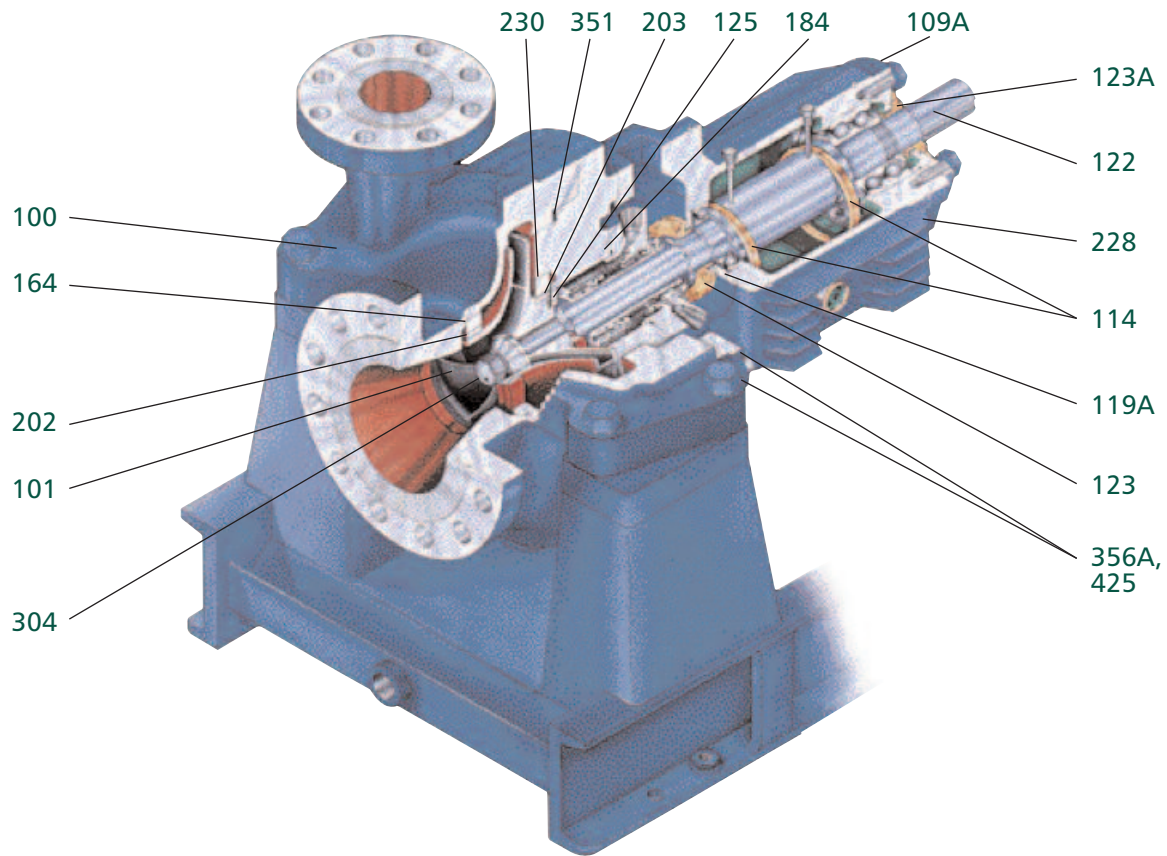

Parts List and Materials of Construction

Item Number	Part Name	API-610 Material Classes				
		S-4	S-6	S-8	C-6	A-8
100	Casing	Carbon Steel			12% Chrome	316L SS
101	Impeller	Carbon Steel	12% Chrome	316L SS	12% Chrome	316L SS
109A	Bearing End Cover - Outboard	Carbon Steel				
114	Oil Ring	Bronze				
119A	Bearing End Cover - Inboard	Carbon Steel				
122	Shaft	AISI 4140 *		316L SS	410 SS	316L SS
123	Labyrinth Seal - Inboard	Bronze/Viton				
123A	Labyrinth Seal - Outboard	Bronze/Viton				
125	Throat Bushing	Cast Iron	410 SS	316L SS	410 SS	316L SS
164	Wear Ring - Casing	Cast Iron	12% Chrome	316L SS	12% Chrome	316L SS
184	Seal Chamber Cover	Carbon Steel			12% Chrome	316L SS
202, 203	Wear Rings - Impeller	Cast Iron	12% Chrome	Nitronic 60	12% Chrome	Nitronic 60
228	Bearing Frame	Carbon Steel				
230	Wear Ring - Seal Chamber Cover	Cast Iron	12% Chrome	316L SS	12% Chrome	316L SS
304	Impeller Nut	Steel	316 SS			
351	Casing Gasket	Spiral Wound 316 SS				
353, 355	Gland Studs and Nuts	AISI 4140				
356A, 425	Casing Studs and Nuts	AISI 4140				

* 410 SS on S-6 when temperature exceeds 350° F (175°C). All other API materials of construction are available.

Hydraulic Coverage

Flow Rate – 50 Hz

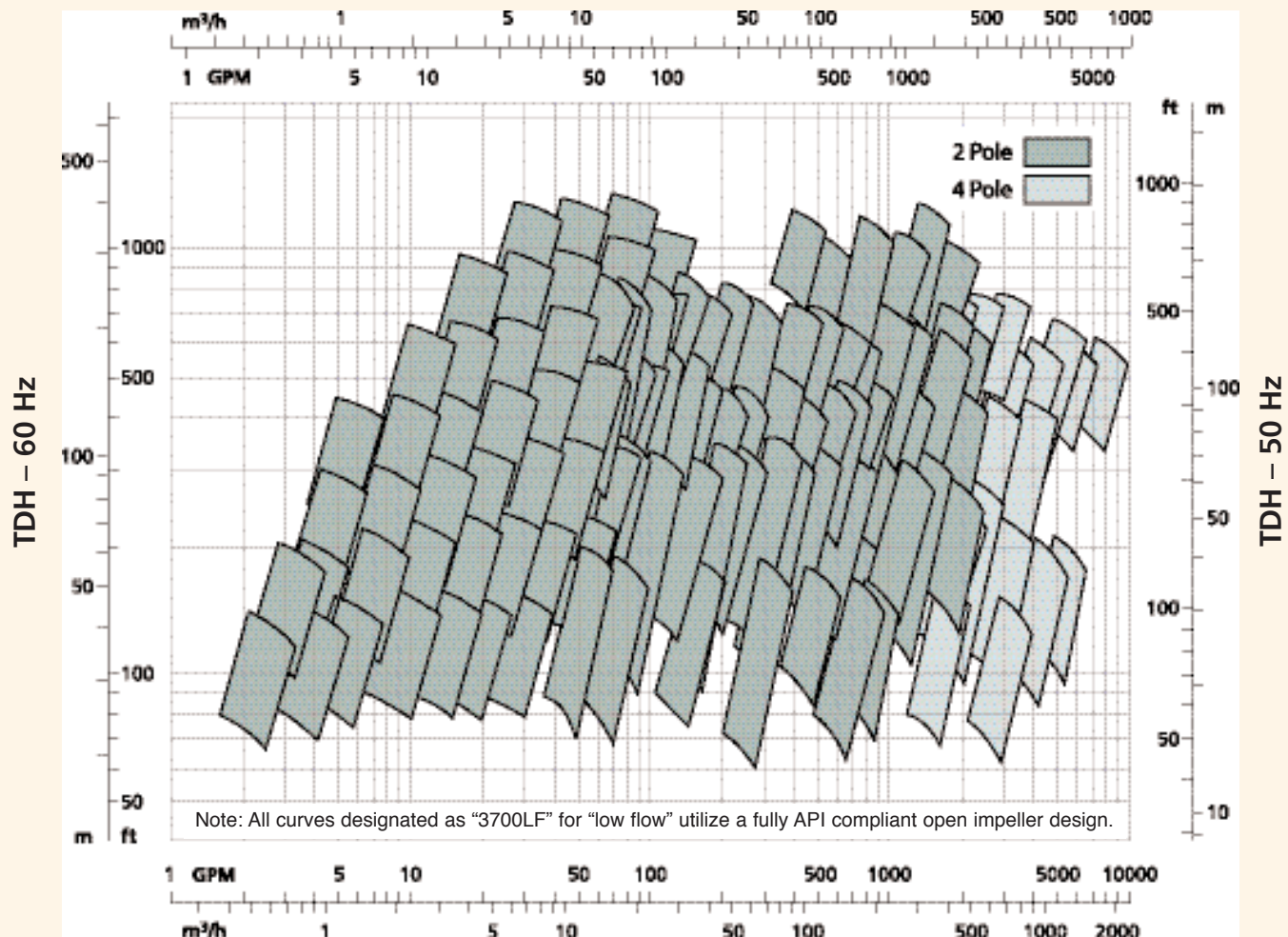

Flow Rate – 60 Hz



Typical 3700 Installation

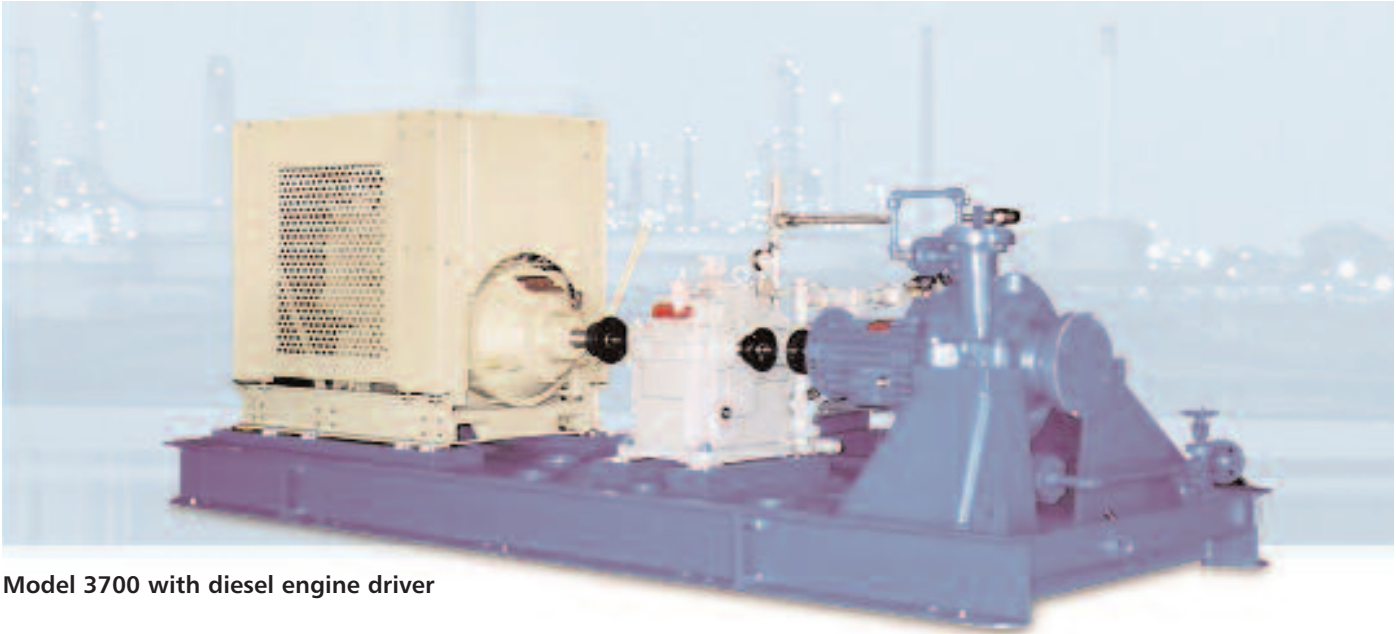

Model 3700 with diesel engine driver

Upgrade Your Older Style API Process Pump

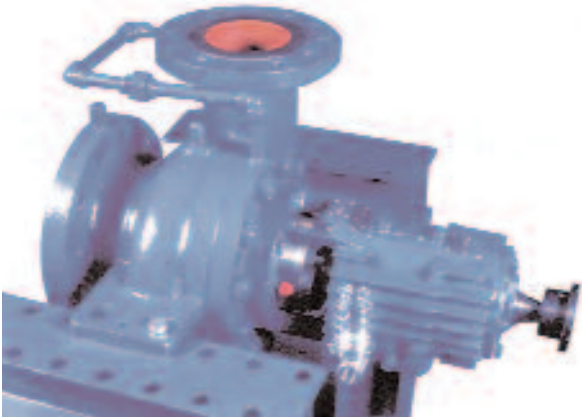

Need an economical alternative to high maintenance costs? Goulds PRO Services® Centers are experienced with reconditioning all types of pumps and rotating equipment, restoring equipment to original specification.

Users continually utilize PRO Services Centers for economical repair versus replacement, decreased downtime, reduced inventory of replacement parts, and the advantage of updated engineering technology.

Benefits:

Years of experience allow PRO Services Centers to easily handle any rotating equipment including pumps, drivers, gear boxes, centrifuges, blowers, fans, and compressors.

Profit from these exclusive quality services:

- Quality rebuilds/repairs ensure maximum reliability from your rotating equipment.
- One-year warranty on all rebuilds/repairs.
- Upgrade old designs to latest technology to maximize reliability.

Your local PRO Services Center offers solutions to lowering Total Cost of Ownership of your pumping systems. This can be achieved by upgrading your older style API process pumps to today's high performance API standard.

The question of whether to Replace or Upgrade your existing equipment is a challenge faced by most end users today. When casing, piping, and foundation are in good shape, upgrading your existing pump to comply with current API standards usually is economically attractive compared to new pump installation. By exploring all options, a better decision can be made.



Upgrades may involve hydraulic modifications, drop in replacements, and/or power end conversions. PRO Services Centers are experienced with all pump manufacturers.





PRO Services® Extending Equipment Life...

Product Repair

- Service Center Repair
- Turnkey Repair/ Installation
- Field Service
- Emergency Service

Reliability Improvement

- Predictive Condition Monitoring
- Root Cause Failure Analysis
- Machine & System Assessment
- Engineered Upgrades
- Training

Optimization of Assets

- Inventory Management
- Replacement/Exchange
- Maintenance Management
- Contract Maintenance

- All Brands
- Factory Trained Service Personnel
- Quality
- Fast Turnaround
- Emergency Service – 24 hours/day, 7 days/week
- ISO and Safety Certified



PROSMART

Predictive Monitoring Saves Money and Down Time

The ProSmart predictive condition monitoring system enables you to IDENTIFY and SOLVE problems before they impact production.

ProSmart collects and analyzes machine health every 5 seconds, automatically notifying you of changing conditions. Resources are optimized and maintenance activities are PLANNED — not REACTIVE.

A wireless architecture reduces installation costs and complexity.

A web-based client eliminates software installation and maintenance costs and also enables multi-site management.

Approved for Class 1, Division 2 hazardous areas.



A Leader in API Engineered Pump Package Solutions

API Family of Pumps

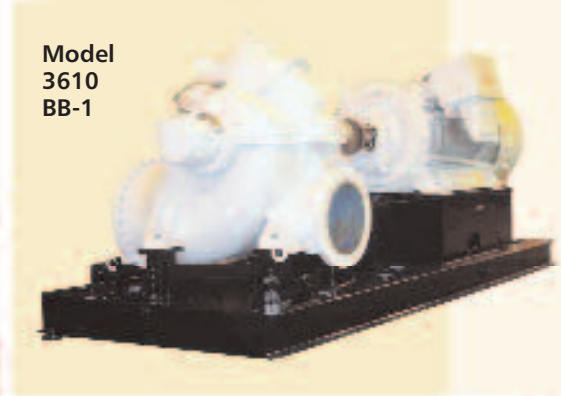
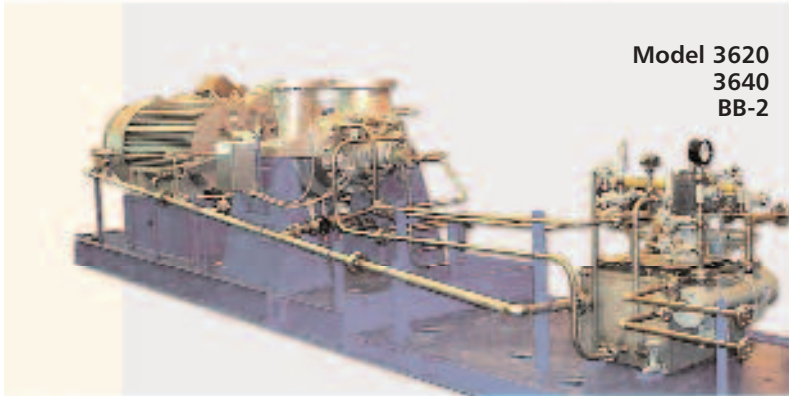
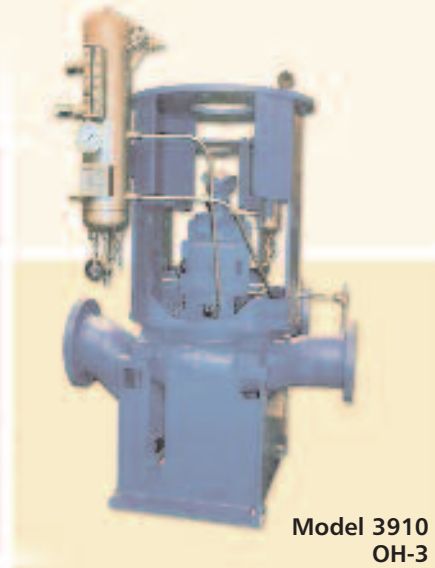
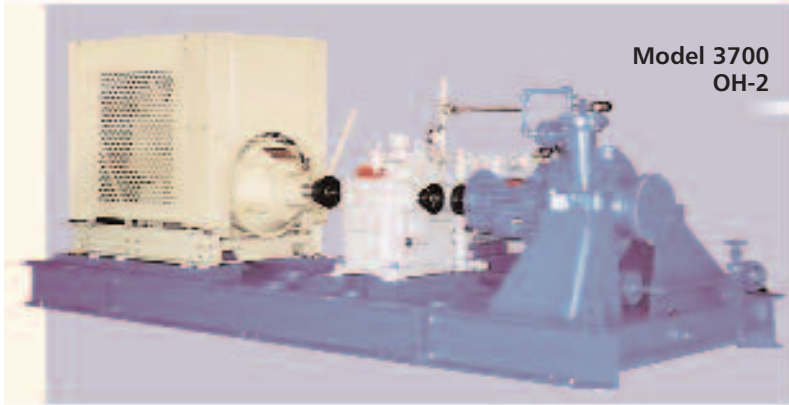

API Type	Goulds Model	Capacity GPM (M ³ /Hour)	TDH Feet (Meters)	Temperature °F (°C)	Pressure PSIG (kg/cm ²)
OH-2	3700	8500 (1930)	1200 (360)	800 (425)	870 (60)
OH-3	3910	6000 (1360)	750 (230)	650 (340)	600 (42)
BB-1	3610	50000 (11355)	700 (215)	300 (150)	300 (21)
BB-2	3640	7500 (1700)	2500 (760)	850 (455)	1130 (75)
BB-2	3620	20000 (4540)	1500 (455)	850 (455)	1000 (70)
BB-3	3600	8500 (1930)	9000 (2740)	400 (205)	4000 (275)
BB-5	7200CB	4000 (910)	9000 (2740)	800 (400)	4000 (275)
VS4	API 3171	3180 (720)	525 (160)	450 (232)	750 (50)
VS1	VIT	70000 (14760)	3500 (1060)	500 (260)	2500 (175)
VS6	VIC	70000 (14760)	3500 (1060)	500 (260)	2500 (175)



Visit our Web site at www.gouldspumps.com

