

Goulds 3400

Double Suction Pumps

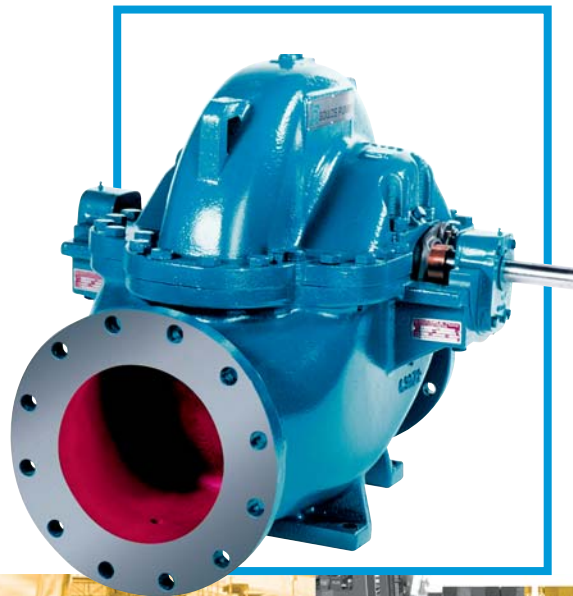

Designing and Manufacturing Dependable Centrifugal Pumps for Over 125 Years.

Model 3498 pumping drinking water through a distribution network in the Western United States.



All 316 stainless steel model 3409 pumps on a solvent extraction application at a large copper mine.

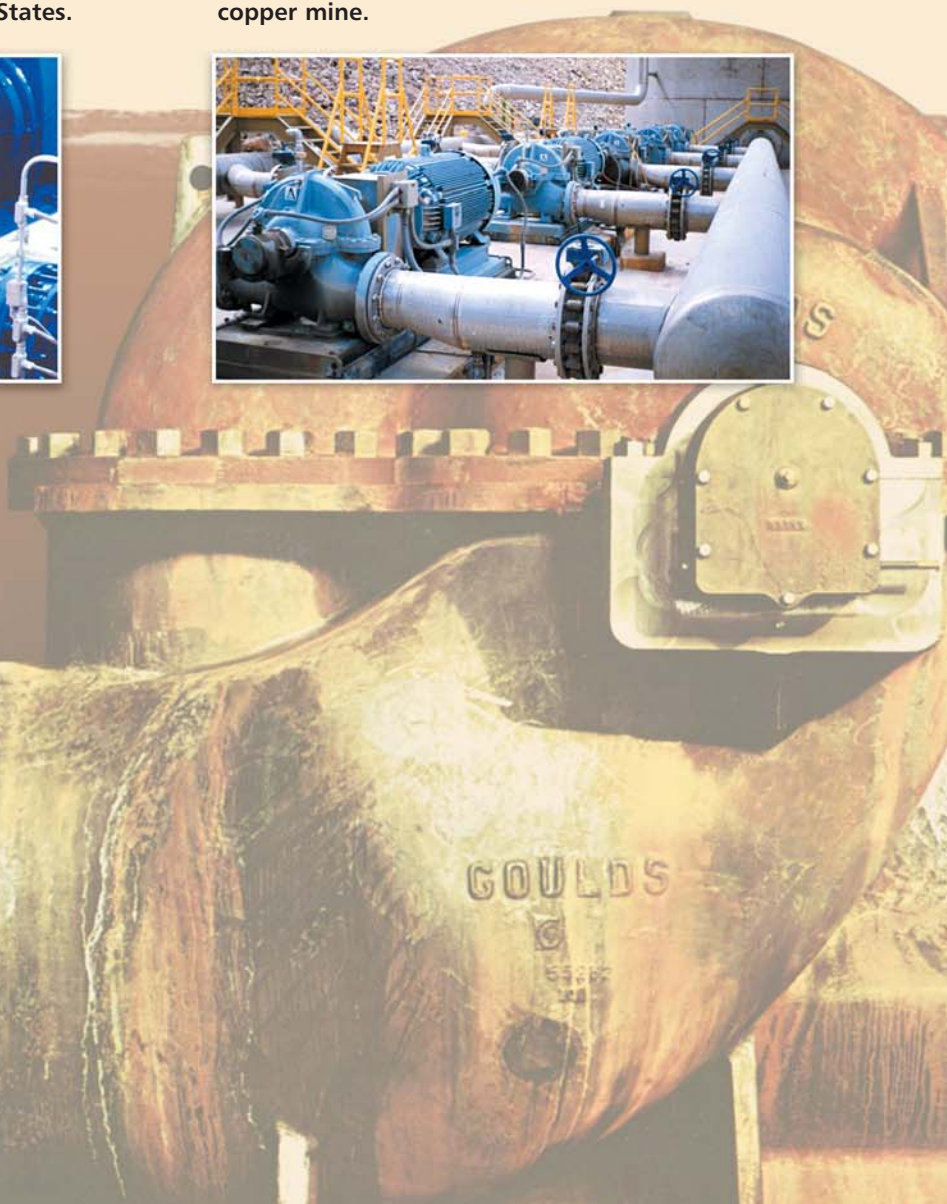

Goulds split case pumps have many applications in the power generation market.



Model 3420 splitcase pump in service at an electric utility plant in the Bahamas.

Goulds 3400

The Most Complete Line of Double Suction Pumps in the Industry

Small Capacity – 3408A

Flows to 8,000 GPM

- ◆ Capacities to 6,000 GPM (1,363 m³/h)
- ◆ Heads to 570 feet TDH (174 m)
- ◆ Temperatures to 250° F (120° C)
- ◆ Working pressures to 175 PSI (1207 kPa)

Medium Capacity – 3409, 3410

Flows to 12,000 GPM

- ◆ Capacities to 12,000 GPM (2,725 m³/h)
- ◆ Heads to 850 feet TDH (259 m)
- ◆ Temperatures to 250° F (120° C)
- ◆ Working pressures to 400 PSI (2758 kPa)

Large Capacity – 3420

Flows to 65,000 GPM

- ◆ Capacities to 65,000 GPM (14,762 m³/h)
- ◆ Heads to 400 feet TDH (122 m)
- ◆ Temperatures to 275° F (135° C)
- ◆ Working pressures to 200 PSI (1379 kPa)

Extra Large Capacity – 3498

Flows to 225,000 GPM

- ◆ Capacities to 225,000 GPM (51,098 m³/h)
- ◆ Heads to 800 feet TDH (244 m)
- ◆ Temperatures to 275° F (135° C)
- ◆ Working pressures to 250 PSI (1,724 kPa)

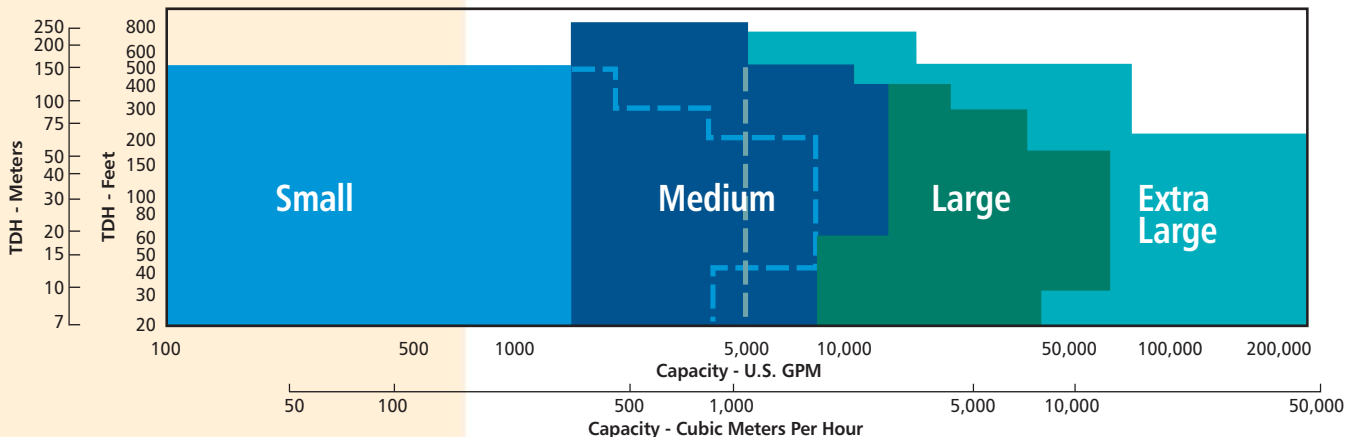
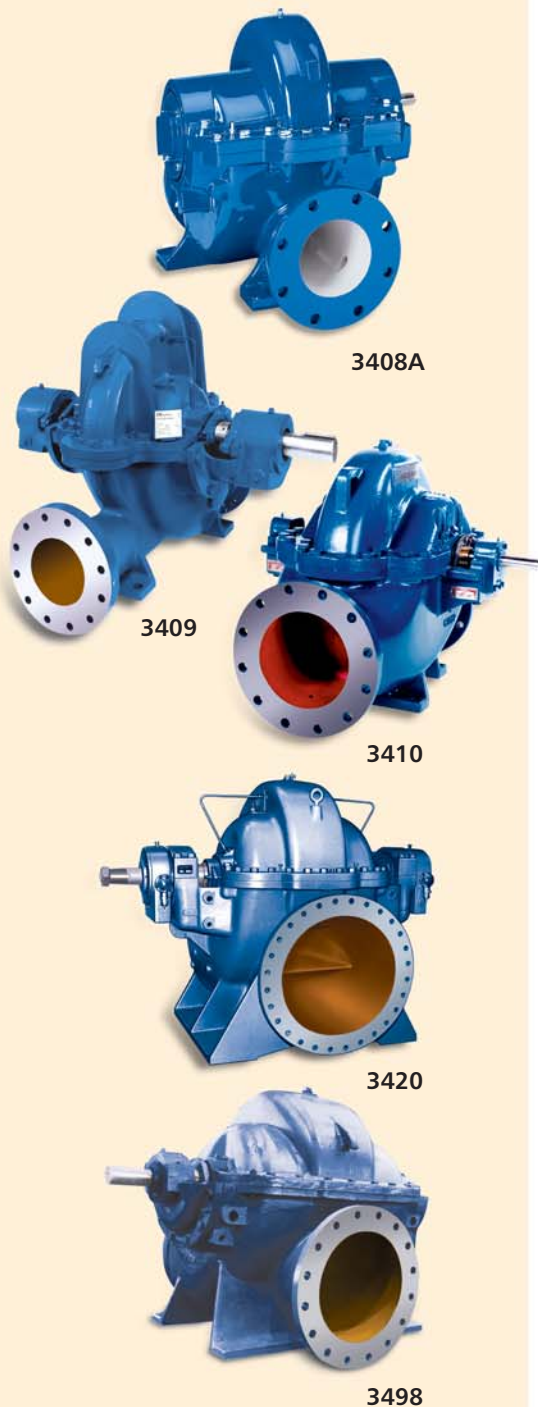

Small Capacity

Model 3408A (General Purpose)

- Grease lubricated bearings
- Mechanical seals standard

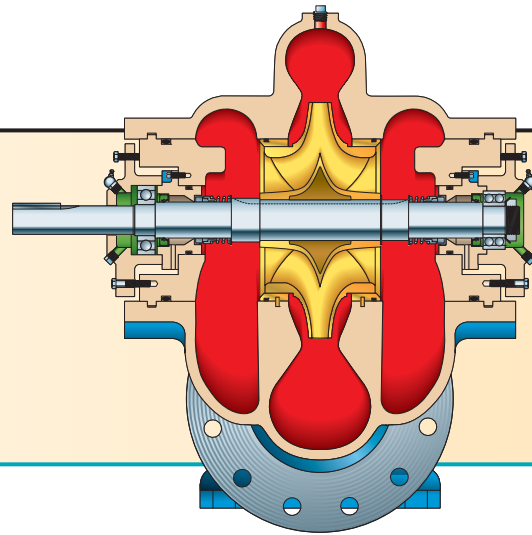

Dimensions

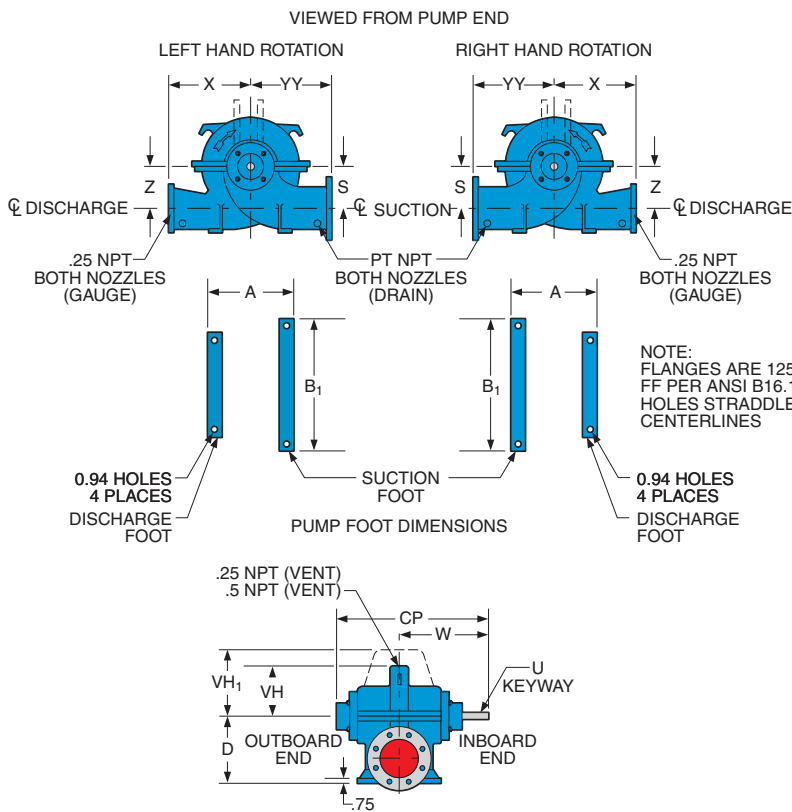

Pump Size	A	B ₁	CP	D	S & Z	VH	VH ₁	W	X	YY
2x3x11	10.00 (254)	13.00 (330)	18.62 (473)	8.00 (203)	5.50 (140)	6.8 (173)	-	11.31 (287)	9.00 (229)	10.00 (254)
4x6x10A	13.50 (343)	15.00 (381)	22.81 (579)	11.00 (279)	7.00 (178)	7.88 (200)	-	13.50 (343)	11.50 (292)	13.00 (330)
4x6x12A	15.00 (381)	15.00 (381)	20.62 (524)	12.00 (305)	7.75 (197)	9.20 (234)	-	13.50 (343)	11.50 (292)	13.00 (330)
4x6x14A	15.00 (381)	15.00 (381)	20.62 (524)	12.00 (305)	7.75 (197)	9.20 (234)	-	12.56 (319)	11.50 (292)	13.00 (330)
4x6x14L	15.00 (381)	15.00 (381)	20.62 (524)	12.00 (305)	7.75 (197)	9.62 (244)	-	12.56 (319)	11.50 (292)	13.00 (330)
6x8x10A	15.00 (381)	15.00 (381)	29.19 (741)	14.00 (356)	8.25 (210)	9.25 (235)	-	17.58 (447)	12.50 (318)	12.50 (318)
6x8x12	15.00 (381)	15.00 (381)	20.62 (524)	14.00 (356)	9.00 (229)	9.6 (244)	-	12.56 (319)	14.00 (356)	14.00 (356)
6x8x12M	15.00 (381)	15.00 (381)	22.81 (579)	14.00 (356)	9.00 (229)	9.6 (244)	-	13.50 (343)	14.00 (356)	14.00 (356)
6x8x13	16.25 (413)	18.50 (470)	26.18 (665)	12.75 (324)	8.00 (203)	9.4 (239)	-	16.06 (408)	13.00 (330)	15.50 (394)
6x8x17	16.25 (413)	18.50 (470)	26.18 (665)	14.00 (356)	9.00 (229)	11.75 (298)	-	16.06 (408)	14.00 (356)	16.00 (406)
8x8x12	16.25 (413)	18.50 (470)	26.18 (665)	12.75 (324)	8.00 (203)	10.25 (260)	11.75 (298)	16.06 (408)	14.00 (356)	16.50 (419)
8x8x17	18.00 (475)	20.00 (508)	28.94 (735)	14.50 (368)	9.50 (241)	12.00 (305)	13.50 (343)	17.56 (446)	15.00 (381)	16.50 (419)
8x10x12	18.00 (475)	20.00 (508)	28.94 (735)	14.25 (362)	8.50 (216)	10.50 (267)	12.00 (305)	17.56 (446)	14.00 (356)	17.00 (432)
8x10x17	18.00 (475)	20.00 (508)	28.94 (735)	16.00 (406)	10.00 (254)	12.81 (325)	14.31 (363)	17.56 (446)	16.00 (406)	18.00 (457)
8x10x20	20.00 (508)	22.00 (559)	28.94 (735)	20.00 (508)	14.00 (356)	15.44 (392)	22.25 (565)	17.56 (446)	18.00 (457)	20.00 (508)
10x10x12	18.00 (457)	22.00 (559)	31.94 (811)	14.75 (375)	9.00 (229)	11.19 (284)	-	19.06 (484)	16.00 (406)	18.00 (457)
10x12x12	18.00 (457)	22.00 (559)	31.94 (811)	16.75 (425)	10.00 (254)	11.50 (292)	-	19.06 (484)	16.00 (406)	19.00 (483)
10x12x14	18.00 (457)	20.00 (508)	28.94 (735)	18.00 (457)	11.00 (279)	13.44 (341)	14.94 (379)	17.56 (446)	18.00 (457)	20.00 (508)
10x12x17	18.00 (457)	20.00 (508)	28.94 (735)	18.00 (457)	11.00 (279)	13.44 (341)	14.94 (379)	17.56 (446)	18.00 (457)	20.00 (508)

All dimensions are in inches (mm) and are not to be used for construction or installation purposes. Standard rotation is right hand (CW). Optional rotation is left hand (CCW).

Materials of Construction

Part Description	Bronze Fitted
Casing	Cast Iron
Impeller	Bronze
Shaft	416 SS
Casing Wear Ring	Bronze
Bearing Housing	Cast Iron
Impeller Wear ring (optional)	Bronze
Bearings	Steel (Anti-Friction)

Small Capacity

Model 3410 (Heavy Duty)

- Horizontal or Vertical Mounting
- Grease or flood oil lubricated bearings
- INPRO VBX labyrinth bearing isolators standard
- Dual volute casings on most sizes
- Alloy constructions not shown below are also available
- Packing or mechanical seals available (including cartridge and split type seals)

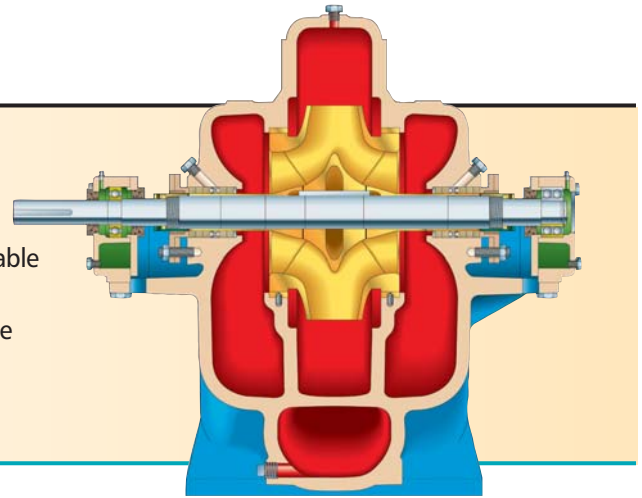

Materials of Construction

Part Description	Bronze Fitted	316 SS Fitted	All 316 SS
Casing	Cast Iron		316 SS
Impeller	Bronze	316 SS	
Lantern Ring	Teflon		
Packing	Graphite Impregnated Yarn		
Packing Gland	316 SS		
Mechanical Seal Gland	Cast Iron		316 SS
Shaft	Carbon Steel		
Shaft Sleeve Nut	Bronze	Nitronic 60	
Shaft Sleeve ¹	Bronze	316 SS	
Casing Wear Ring ¹	Bronze	Nitronic 60	
Bearing Housing	Cast Iron		
Impeller Wear Ring (optional) ¹	Bronze	316 SS	
Bearings	Steel (Anti-Friction)		

¹ Also available in hardened/hard metal coated materials.

Dimensions

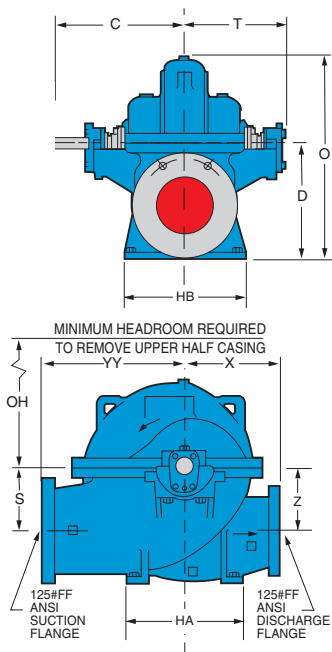

Frame Group	Pump Size	C	T	D	O	OH	S & Z	X	YY	HA	HB	Wt. Lbs. (kg)
S	2x3-11				18.38 (467)	12.38 (314)	7.25 (184)	7.50 (190)	9.00 (229)			330 (150)
	3x4-10				18.91 (480)	12.75 (324)	7.00 (178)	9.00 (229)	10.50 (267)			333 (151)
	4x6-9	14.62 (371)	11.76 (209)	11.50 (292)	17.88 (454)	10.88 (276)	6.00 (152)	8.50 (216)	10.00 (254)	12.00 (305)	12.50 (318)	334 (152)
	4x6-11/H				19.22 (488)	13.25 (336)	6.00 (152)	10.50 (267)	12.38 (314)			410 (186)
	4x6-13/H				20.59 (523)	15.88 (403)	6.00 (152)	11.00 (279)	13.25 (336)			472 (215)
M	4x6-15				25.88 (657)	17.38 (441)	9.50 (241)	10.00 (254)	14.50 (368)			637 (290)
	6x8-11				26.44 (672)	16.00 (406)	9.00 (229)	12.00 (305)	14.50 (368)			692 (315)
	6x8-14/H				25.75 (654)	16.75 (425)	9.00 (229)	13.00 (330)	15.50 (394)			665 (302)
	6x8-17	18.00 (457)	13.88 (353)	16.00 (406)	27.88 (708)	20.62 (524)	9.00 (229)	14.25 (362)	15.75 (400)	16.00 (406)	16.75 (425)	885 (402)
	8x10-11				25.50 (648)	15.25 (391)	9.00 (229)	13.25 (336)	17.00 (432)			737 (335)
8x10-12				27.31 (694)	17.38 (441)	8.75 (222)	13.00 (330)	19.50 (495)			858 (398)	
8x10-14				28.50 (724)	19.50 (495)	8.75 (222)	13.88 (352)	19.50 (495)			996 (453)	
L	6x8-22				40.50 (1029)	22.50 (572)	13.50 (343)	20.50 (520)	22.00 (559)			1495 (680)
	6x10-17				33.88 (860)	20.62 (524)	11.00 (279)	16.50 (419)	20.00 (508)			1015 (461)
	8x10-17/H				34.06 (865)	20.88 (530)	10.00 (254)	16.50 (419)	20.00 (559)			1286 (585)
	8x10-21	21.00 (533)	16.28 (414)	22.00 (559)	36.31 (922)	24.88 (632)	13.00 (330)	17.00 (432)	20.30 (521)	22.50 (572)	18.00 (457)	1520 (691)
	10x12-12				34.88 (886)	19.12 (486)	11.00 (279)	14.00 (356)	21.00 (533)			1229 (559)
10x12-14				34.00 (864)	19.25 (489)	11.00 (279)	16.75 (426)	21.00 (533)			1410 (641)	
10x12-17				37.50 (952)	30.75 (781)	11.50 (292)	17.62 (448)	22.50 (572)			1709 (777)	
XL	10x12-12 H				39.50 (1003)	21.75 (552)	13.00 (330)	15.00 (381)	22.00 (559)			2168 (985)
	10x12-15	23.19 (589)	17.64 (448)	24.00 (610)	38.00 (965)	21.50 (533)	13.00 (330)	16.00 (406)	24.00 (610)	22.50 (572)	27.00 (686)	1720 (782)
	12x14-15				36.50 (927)	21.75 (552)	13.00 (330)	18.00 (457)	25.00 (635)			2500 (1136)

All dimensions are in inches (mm) and are not to be used for construction or installation purposes. Sizes 2x3-11, 4x6-11/H, 3x4-10, 8x10-21 & 6x8-22 are furnished with 250# FF discharge flange as standard. Standard rotation is right hand (CW). Optional rotation is left hand (CCW). Steel casings will have 150#RF or 300#RF flanges.



Model 3400

Standard Design Features for a Wide Range of Heavy-Duty Industrial, Municipal and Process Services

RENEWABLE CASING WEAR RINGS

Eliminate casing wear and permit easy maintenance of proper running clearances for maximum efficiency operation. Positively locked in place in the lower casing half to prevent rotation during pump operation.

HEAVY DUTY SHAFTS

Designed for minimum deflection in the toughest services means excellent shaft seal and bearing life. Renewable shaft sleeves are available in a variety of materials (including hardened metals and hard metal coated) to protect shaft from pumpage.

DOUBLE SUCTION IMPELLER

Minimizes axial thrust for longer bearing life. Polished waterways and fully machined exterior surfaces assure highly efficient performance. Dynamically balanced as standard for smooth operation.

HEAVY DUTY CASINGS

Rugged foot-mounted design to resist external forces and vibration. Casings designed to withstand high working pressures with minimum distortion and are 100% hydrostatically tested per Hydraulic Institute standards. Suction and discharge connections are in the lower half casing, allowing removal of upper half casing for inspection or removal of complete rotating element without disturbing piping or driver. (Bottom suction casings available on some 3498 sizes.)

BALANCED DESIGN

Dual volute casing design (not available on all sizes). Ideal when pumps must periodically operate at capacities above or below design capacity or at interrupted high head. Combined with double suction impeller for axial balance, the 3400 series is designed for high reliability and low maintenance.

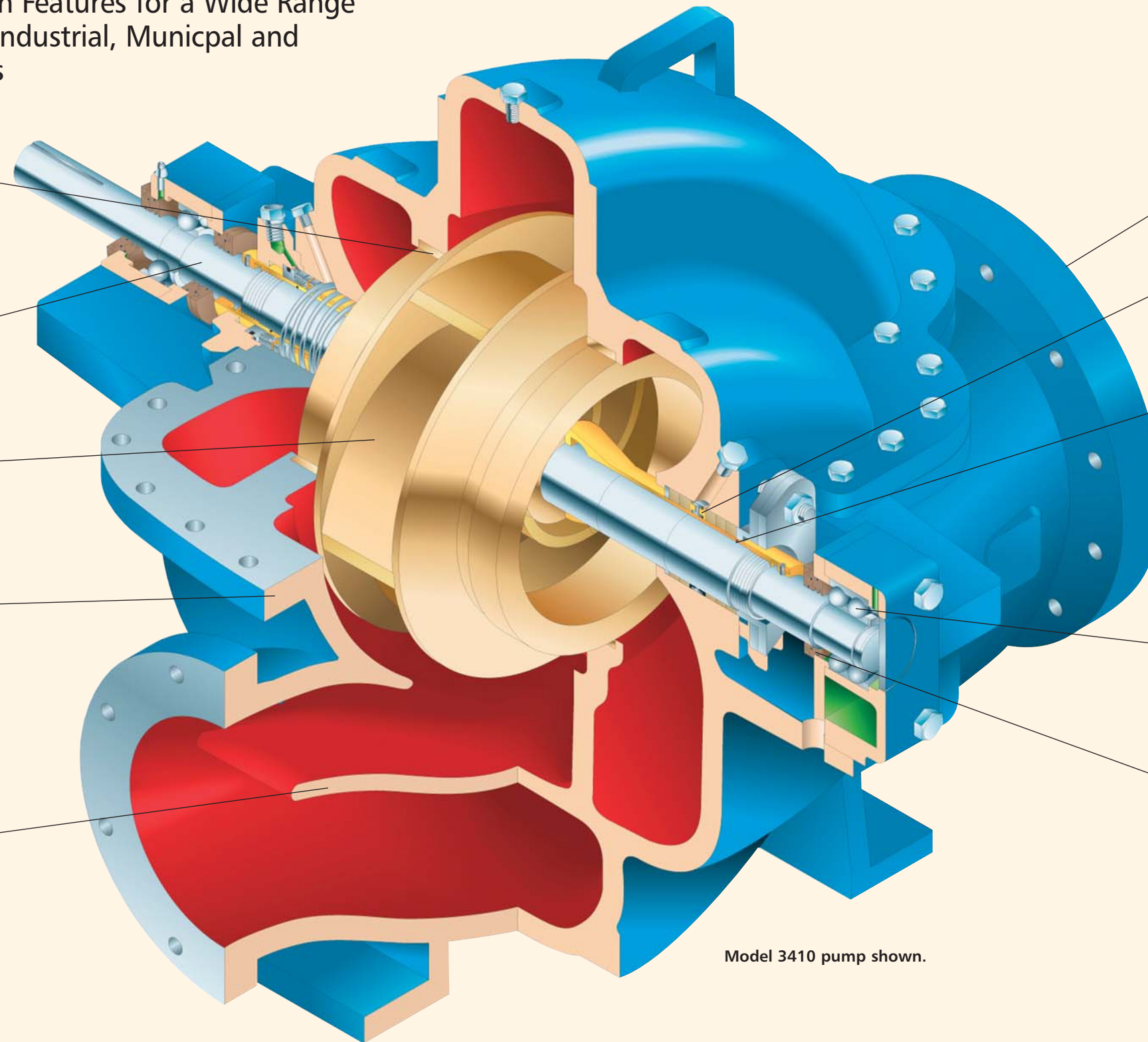

Model 3410 pump shown.

LARGE INLET AREAS

Reduce NPSH requirements and assure smooth, quiet flow to the impeller.

STUFFING BOX

Packing is standard on 3400 series product. A wide variety of mechanical seals, including cartridge and split type, are also available to suit the application.

POSITIVE LIQUID SEALING

Shaft is positively sealed from pumpage between impeller and sleeves as well as between sleeves and sleeve nuts standard on all 3400 series pumps.

RENEWABLE IMPELLER WEAR RINGS

Positively locked on impeller hubs permit easy renewal of running clearance and protect impeller hubs from wear. Standard on large and extra large capacity models (3420 & 3498). Optional on all others.

DOUBLE ROW THRUST BEARING

Double row thrust bearing for high axial thrust capability is standard on all 3400 series pumps. Locked on shaft in bearing housing positively positions rotating element and easily carries any residual axial thrust.

LABYRINTH BEARING PROTECTION

Standard on all 3400 series pumps (except general purpose model 3408). Significantly reduces the chance for bearing contamination and greatly improves mean time between failure.

Medium Capacity

Model 3409

- Horizontal and vertical mounting
- Grease or ring oil lubricated bearings
- INPRO VBX labyrinth bearing isolators standard
- High pressure casings available
- Dual volute casings standard on all sizes
- Packing or mechanical seals available, (including cartridge and split type seals)
- Alloy constructions not shown below are also available

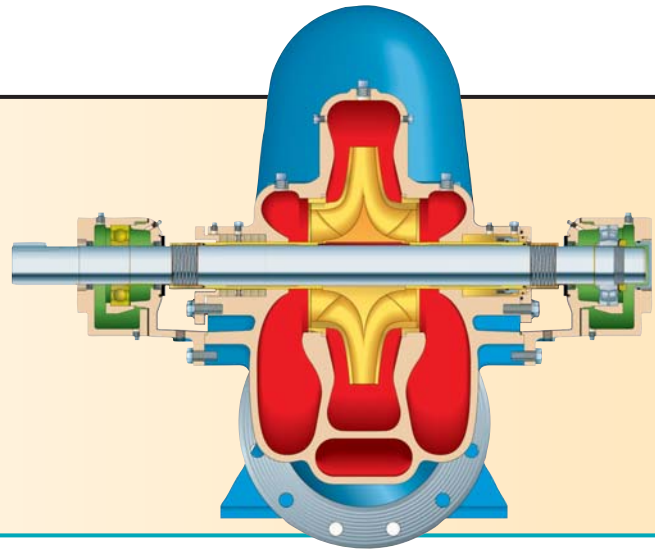

Materials of Construction

Part Description	Bronze Fitted	All Iron	316 SS Fitted	All 316 SS
Casing		Cast Iron ¹		316 SS
Impeller	Bronze	Cast Iron	316 SS	
Lantern Ring			Teflon	
Packing			Graphite Impregnated Yarn	
Packing Gland	Bronze	Cast Iron	316 SS	
Mechanical Seal Gland		Cast Iron	316 SS	
Shaft			Carbon Steel ²	
Shaft Sleeve Nut	Bronze	Cast Iron	Nitronic 60	
Shaft Sleeve ³	Bronze	Cast Iron	316 SS	
Casing Wear Ring ³	Bronze	Cast Iron	Nitronic 60	
Bearing Housing		Cast Iron		
Impeller Wear Ring (optional) ³	Bronze	Cast Iron	316 SS	
Bearings			Steel (Anti-Friction)	

¹ Size 8x12-27 casing material is ductile iron as standard. ² Shaft material will be 17-4 PH for certain size & speed combinations. ³ Also available in hardened/hard metal coated materials.

Dimensions

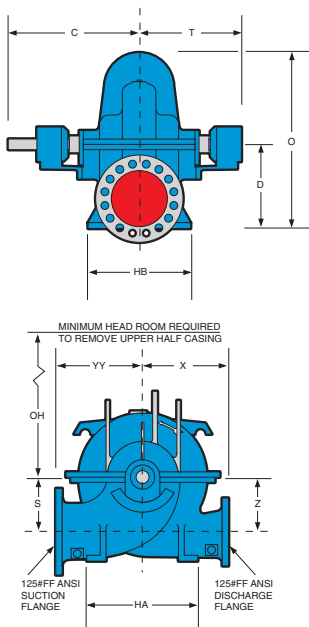

Frame Group	Pump Size	C	T	D	O	OH	S & Z	X	YY	HA	HB	Weight Lbs. (kg)	
S	6x10-22				37.9 (962)	30.4 (772)		19 (483)	20			1545 (701)	
	8x12-21	28.3 (718)	21.8 (552)	19 (483)		30.8 (782)	12 (305)			24 (610)	18 (457)	1905 (864)	
	8x12-22M				38.9 (988)	30.4 (772)		21 (533)	21 (533)			1920 (871)	
	8x12-22L					31.4 (798)						1930 (875)	
8x12-27								43.9 (1115)	36.4 (924)			14.2 (360)	23 (584)
M	10x14-20S			21 (533)	42.8 (1086)	31.7 (804)	13 (330)	19 (483)	21 (533)	24 (610)	24 (610)	2000 (907)	
	10x14-20L	30.5 (775)	23.8 (603)									2050 (930)	
	12x16-23			23 (584)	48.9 (1242)	37.4 (949)	14 (356)	25 (635)	25 (635)			2600 (1179)	
	14x16-17			23.5 (597)	46.3 (1181)	31.8 (806)		18 (457)	24 (610)			2860 (1297)	
	14x18-23			31.6 (802)	24.8 (629)	24 (610)	47.6 (1210)	35.1 (892)	14 (356)			27 (686)	27 (686)
14x18-28	26 (660)					56.8 (1441)	44.7 (1135)	16 (406)	28 (711)	28 (711)	3255 (1476)		

Sizes 6x10-22, 8x12-21, 8x12-22M, 8x12-22L are furnished with 250# FF discharge flange as standard.

Size 8x12-27 is furnished with 250# FF suction and discharge flange as standard.

All dimensions in inches (mm) and are not to be used for construction or installation purposes.

Standard rotation is right hand (CW). Optional rotation is left hand (CCW). Steel casings will have 150#RF or 300#RF flanges.

Large Capacity

Model 3420

- Sleeve bearings available
- Grease or ring oil lubricated bearings
- Packing or mechanical seals available (including cartridge and split type seals)
- Dual volute casings standard on all sizes
- Labyrinth bearing protection standard
- Alloy constructions not shown below are also available
- Shaft sleeve nuts threaded against rotation as standard
- Vertical mounting available on some sizes
- Impeller wear rings standard

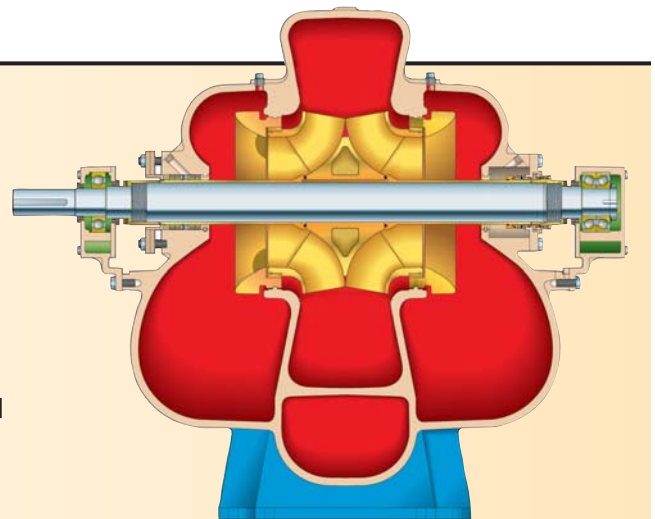

Materials of Construction

Part Description	Bronze Fitted	All Iron	316 SS Fitted	All 316 SS
Casing		Cast Iron		316 SS
Impeller	Bronze	Cast Iron		316 SS
Lantern Ring		Teflon		
Packing		Graphite Impregnated Yarn		
Packing Gland	Bronze	Cast Iron		316 SS
Mechanical Seal Gland		Cast Iron		316 SS
Shaft		Carbon Steel		
Shaft Sleeve Nut	Bronze	Cast Iron		316 SS
Shaft Sleeve ¹	Bronze	Cast Iron		316 SS
Casing Wear Ring ¹	Bronze	Cast Iron		316 SS
Bearing Housings		Cast Iron		
Impeller Wear Ring ¹	Bronze	Cast Iron		316 SS
Bearings		Steel (Anti-Friction)		

¹ Also available in hardened/hard metal coated materials.

Dimensions

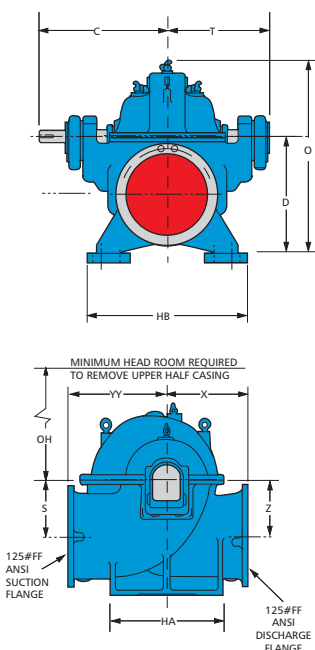

Pump Size	C	T	D	O	OH	S & Z	X	YY	HA	HB	Weight Lbs. (kg)
12x14-15	33.0 (838)	26.8 (679)	26.4 (670)	42.3 (1073)	25.0 (635)	14.8 (375)	17.8 (451)	24.8 (629)	33.0 (838)	24.0 (610)	2600 (1179)
16x18-17/H	33.0 (838)	26.8 (679)	33.5 (851)	54.3 (1378)	31.0 (787)	18.8 (476)	20.9 (530)	31.5 (800)	33.0 (838)	24.0 (610)	3500 (1588)
16x18-30/G/H	44.4 (1127)	36.6 (930)	36.0 (914)	62.3 (1581)	41.3 (1048)	22.5 (572)	28.0 (711)	34.0 (864)	46.0 (1168)	47.0 (1194)	7060 (3202)
18x20-24/G	39.1 (992)	30.8 (783)	35.5 (902)	59.9 (1521)	38.0 (965)	19.5 (495)	20.6 (524)	38.9 (989)	49.0 (1245)	46.0 (1168)	5650 (2563)
18x20-30	44.4 (1127)	36.6 (930)	37.5 (953)	64.3 (1632)	41.8 (1060)	22.8 (578)	29.0 (737)	35.0 (889)	48.0 (1219)	47.0 (1194)	7500 (3402)
20x24-24	44.4 (1127)	36.6 (930)	38.0 (965)	63.8 (1619)	37.8 (959)	20.5 (521)	26.6 (675)	34.0 (864)	42.0 (1067)	47.0 (1194)	7200 (3266)
20x24-28/G/H	37.9 (962)	37.9 (962)	42.1 (1070)	70.3 (1784)	44.0 (1118)	23.1 (587)	24.5 (622)	46.2 (1173)	56.0 (1422)	54.0 (1372)	8650 (3924)
20x24-30	46.0 (1168)	36.6 (930)	40.5 (1029)	68.0 (1727)	42.5 (1080)	23.5 (597)	29.5 (749)	36.0 (914)	50.0 (1270)	47.0 (1194)	8000 (3629)
24x30-32/G/H/N	44.4 (1127)	39.8 (1010)	44.0 (1118)	74.1 (1883)	45.0 (1143)	22.5 (572)	36.0 (914)	50.0 (1270)	56.0 (1422)	51.0 (1295)	11,500 (5216)
30x30-31/G	50.0 (1270)	42.9 (1089)	53.3 (1353)	86.4 (2196)	50.7 (1287)	33.4 (848)	40.0 (1016)	52.0 (1321)	63.4 (1610)	53.4 (1356)	16,200 (7348)
30x30-38/G	53.0 (1346)	42.9 (1089)	53.3 (1353)	87.5 (2223)	53.3 (1353)	30.8 (781)	36.5 (927)	54.5 (1384)	63.4 (1610)	53.4 (1356)	15,400 (6985)
30x36-42/G/H	60.8 (1545)	47.6 (1210)	58.0 (1473)	97.5 (2477)	62.0 (1575)	34.0 (864)	36.0 (914)	54.5 (1384)	78.0 (1981)	76.0 (1930)	25,250 (11,453)

All dimensions in inches (mm) and are not to be used for construction or installation purposes. Standard rotation is right hand (CW). Optional rotation is left hand (CCW). Steel casings will have 150#RF flanges.

Extra Large Capacity

Model 3498

- Sleeve bearings available
- Grease or ring oil lubricated bearings
- Packing or mechanical seals available (including cartridge and split type seals)
- Dual volute casings standard on some sizes.
- Bottom suction available on some sizes
- Vertical mounting available on some sizes
- Alloy constructions not shown below are also available
- Shaft sleeve nuts threaded against rotation as standard
- Impeller wear rings standard

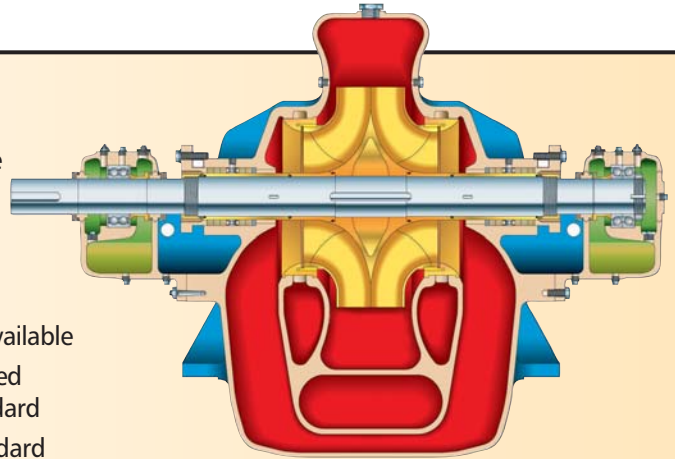

Dimensions

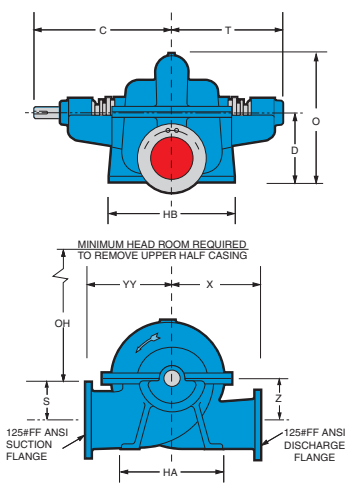

Materials of Construction

Part Description	Bronze Fitted	All Iron	316 SS Fitted	All 316 SS
Casing		Cast Iron		316 SS
Impeller	Bronze	Cast Iron		316 SS
Lantern Ring			Teflon	
Packing			Graphite Impregnated Yarn	
Packing Gland	Bronze	Cast Iron		316 SS
Mechanical Seal Gland		Cast Iron		316 SS
Shaft		Carbon Steel		
Shaft Sleeve Nut	Bronze	Cast Iron		316 SS
Shaft Sleeve ¹	Bronze	Cast Iron		316 SS
Casing Wear Ring ¹	Bronze	Cast Iron		316 SS
Bearing Housings		Cast Iron		
Impeller Wear Ring ¹	Bronze	Cast Iron		316 SS
Bearings		Steel (Anti-Friction)		

¹ Also available in hardened/hard metal coated materials.

Pump Size	C	T	D	O	OH	S	Z	X	YY	HA	HB	Weight Lbs. (kg)
12x16-28	39.0 (991)	49.0 (1245)	7.0 (178)	23.0 (584)	29.5 (749)	19.0 (483)	19.0 (483)	36.0 (914)	34.0 (864)	31.0 (787)	44.0 (1118)	5900 (2676)
12x18-34*	42.0 (1067)	35.0 (889)	29.0 (737)	54.0 (1372)	42.3 (1073)	22.5 (572)	24.0 (610)	30.0 (762)	38.0 (965)	51.0 (1295)	44.0 (1118)	6600 (2994)
16x18-18*	33.0 (838)	31.0 (787)	23.0 (584)	38.0 (965)	23.9 (606)	13.0 (330)	14.0 (356)	17.0 (432)	24.0 (610)	24.0 (610)	38.0 (965)	3000 (1361)
16x18-28*	40.0 (1016)	36.0 (914)	29.0 (737)	52.0 (1321)	36.7 (931)	23.0 (584)	22.0 (559)	34.0 (864)	35.0 (889)	51.0 (1295)	42.0 (1067)	5000 (2268)
16x20-24	45.0 (1143)	35.5 (902)	28.0 (711)	49.0 (1245)	33.5 (851)	17.0 (432)	19.5 (495)	24.0 (610)	30.0 (762)	30.0 (762)	42.0 (1067)	4600 (2087)
18x20-24*	39.0 (991)	32.0 (813)	26.0 (660)	47.0 (1194)	33.3 (845)	18.0 (457)	19.0 (483)	21.0 (533)	32.0 (813)	35.0 (889)	51.0 (1295)	4380 (1987)
20x20-18	36.0 (914)	31.0 (787)	29.0 (737)	47.0 (1194)	26.5 (673)	18.0 (457)	18.0 (457)	18.0 (457)	29.0 (737)	31.0 (787)	40.0 (1016)	3480 (1579)
16x24-24	40.0 (1016)	33.0 (838)	20.0 (508)	41.0 (1041)	33.5 (851)	20.0 (508)	20.0 (508)	22.0 (559)	34.0 (864)	36.0 (914)	42.0 (1067)	5700 (2585)
16x24-38*	49.0 (1245)	41.0 (1041)	32.0 (813)	59.5 (1511)	46.5 (1181)	26.0 (660)	26.0 (660)	48.0 (1219)	42.0 (1067)	53.0 (1346)	50.0 (1270)	11,000 (4990)
20x24-34*	45.0 (1143)	38.0 (965)	24.0 (610)	48.0 (1219)	40.5 (1029)	24.0 (610)	21.0 (533)	36.0 (914)	39.0 (991)	56.0 (1422)	50.0 (1270)	6980 (3166)
20x24-20	40.0 (1016)	38.0 (965)	34.0 (864)	55.0 (1397)	30.7 (780)	21.0 (533)	21.0 (533)	25.0 (635)	33.0 (838)	40.0 (1016)	46.0 (1168)	5500 (2495)
20x24-20S/L	34.0 (864)	28.0 (711)	20.0 (508)	40.0 (1016)	29.6 (752)	20.0 (508)	20.0 (508)	20.0 (508)	42.0 (1067)	38.0 (965)	48.0 (1219)	5100 (2313)
24x24-26*	40.0 (1016)	36.0 (914)	35.0 (889)	56.0 (1422)	33.8 (857)	21.0 (533)	21.0 (533)	26.0 (660)	35.0 (889)	40.0 (1016)	54.0 (1372)	6650 (3016)
20x30-28*	44.0 (1118)	36.0 (914)	23.0 (584)	48.0 (1219)	39.0 (991)	23.0 (584)	23.0 (584)	27.0 (686)	40.0 (1016)	42.0 (1067)	48.0 (1219)	6750 (3062)
20x30-34*	51.0 (1295)	40.0 (1016)	30.3 (768)	56.0 (1422)	43.0 (1092)	22.5 (572)	22.5 (572)	34.3 (870)	42.0 (1067)	44.0 (1118)	60.0 (1524)	12,200 (5534)
20x30-40*	52.0 (1321)	41.0 (1041)	34.0 (864)	64.0 (1626)	49.5 (1257)	26.3 (667)	26.3 (667)	33.0 (838)	46.0 (1168)	44.0 (1118)	60.0 (1524)	13,500 (6123)
24x30-30*	51.0 (1295)	55.0 (1397)	31.0 (787)	59.0 (1499)	43.4 (1102)	19.0 (483)	22.0 (559)	30.0 (762)	45.0 (1143)	52.0 (1321)	56.0 (1422)	9500 (4309)
24x36-40*	62.0 (1575)	49.0 (1245)	34.0 (864)	68.0 (1727)	54.0 (1372)	29.0 (737)	29.0 (737)	63.0 (1600)	50.0 (1270)	72.0 (1829)	65.0 (1651)	17,500 (7938)
24x36-48*	58.0 (1473)	56.0 (1422)	40.0 (1016)	82.0 (2083)	66.0 (1676)	40.0 (1016)	39.0 (991)	46.0 (1168)	66.0 (1676)	92.0 (2337)	66.0 (1676)	26,200 (11,884)
30x36-34*	56.0 (1422)	49.0 (1245)	36.0 (914)	66.0 (1676)	47.5 (1207)	24.0 (610)	27.0 (686)	33.0 (838)	51.0 (1295)	57.0 (1448)	78.0 (1981)	13,000 (5897)
30x36-35*	62.0 (1575)	50.0 (1270)	36.0 (914)	66.0 (1676)	47.5 (1207)	24.0 (610)	27.0 (686)	33.0 (838)	51.0 (1295)	57.0 (1448)	78.0 (1981)	15,000 (6804)
30x36-36	58.0 (1473)	49.0 (1245)	48.0 (1219)	79.0 (2007)	49.3 (1251)	27.0 (686)	30.0 (762)	38.0 (965)	50.0 (1270)	51.0 (1295)	72.0 (1829)	18,500 (8391)
30x42-46	72.0 (1829)	61.0 (1549)	48.0 (1219)	86.0 (2184)	60.5 (1537)	31.0 (787)	36.0 (914)	84.0 (2134)	54.0 (1372)	75.0 (1905)	96.0 (2438)	22,500 (10,206)
30x42-48*	66.0 (1676)	63.0 (1600)	42.0 (1067)	81.0 (2057)	63.0 (1600)	38.0 (965)	38.0 (965)	50.0 (1270)	72.0 (1829)	90.0 (2286)	79.0 (2007)	24,400 (11,068)
30x42-72*	69.0 (1753)	67.0 (1702)	54.0 (1372)	106.0 (2692)	87.5 (2223)	51.0 (1295)	51.0 (1295)	78.0 (1981)	84.0 (2134)	126.0 (3200)	84.0 (2134)	34,200 (15,513)
36x42-40*	62.0 (1575)	51.0 (1295)	45.0 (1143)	81.0 (2057)	55.5 (1410)	29.0 (737)	30.0 (762)	39.0 (991)	57.0 (1448)	69.0 (1753)	92.0 (2337)	23,300 (10,569)
42x48-48*	69.0 (1753)	58.0 (1473)	54.0 (1372)	97.0 (2464)	67.4 (1711)	33.0 (838)	37.0 (940)	48.0 (1219)	69.0 (1753)	76.0 (1930)	102.0 (2591)	34,000 (15,422)
48x54-58	83.0 (2108)	72.0 (1829)	60.0 (1524)	113.0 (2870)	82.2 (2088)	44.0 (1118)	44.0 (1118)	45.0 (1143)	84.0 (2134)	95.0 (2413)	124.0 (3150)	44,000 (19,958)
48x54-64	69.0 (1753)	60.0 (1524)	45.0 (1143)	90.0 (2286)	76.8 (1951)	45.0 (1143)	45.0 (1143)	50.0 (1270)	86.0 (2184)	102.0 (2591)	88.0 (2235)	50,400 (22,861)
54" to 78" Suction	CONSULT FACTORY											

All dimensions in inches (mm) and are not to be used for construction or installation purposes. Standard rotation is right hand (CW). Optional rotation is left hand (CCW). Side suction casing illustrated. Asterisks indicate sizes available with bottom suction casing. Steel casings will have 150#RF flanges.



PRO Services® Extending Equipment Life...

Product Repair (all types and brands of rotating equipment)

- Service Center Repair
- Field Service
- Parts Supply

Reliability Improvement

- Inventory Management
- Replacement/Exchange
- Turnkey Repair/Installation
- Training

Optimization of Assets

- Predictive Analysis/Condition Monitoring
- Root Cause Failure Analysis
- Pump & System Assessments
- Upgrades – Mechanical & Hydraulic
- Maintenance Management/Contract Maintenance

- Technical Expertise
- Fast Turnaround
- Factory Trained Service Personnel
- Emergency Service – 24 hours/day, 7 days/week
- Quality
- ISO and Safety Certified

PROSMART

ProSmart™ encompasses the latest technology* in condition monitoring to transform your Predictive Maintenance program into a Plant Profitability program. It provides a cost-effective solution to maintaining uptime on all of your rotating equipment. ProSmart continuously monitors, analyzes and annunciates an alarm when critical criteria is not met. By identifying, diagnosing, and sounding an alert to potential equipment problems before they have a chance to manifest into unexpected downtime or catastrophic failure, ProSmart helps to assure plant profitability.



ProSmart delivers benefits that go right to the bottom line.

- Extends equipment life
- Optimizes costly “walk arounds” by skilled personnel
- Can help reduce overall equipment failures and the cost of downtime
- Sends alerts prior to potential catastrophic process failures
- Automatically alerts personnel to machine problems
- Consolidates data for equipment optimization (*Patent pending)

ProSmart is a wireless machinery monitoring system that collects and analyzes operating data automatically every 5 seconds. Integrated analysis capabilities provide enhanced data and reporting functions.

PUMPSMART System Options

- Energy savings
- Provides for pump protection
- Low flow protection (torque-based) when low levels are encountered in standpipe
- Provides upper speed limit to protect motor and drive from excessive load
- Provides lower speed limit to allow Model 3500XD air removal system to work satisfactorily
- Several proven control schemes allow for the maximum benefit of variable speed drive system
- Allows for future operating condition with same pump
- Allows for same pump size to be used when multiple pumps are involved with large TDH variations among them
- Allows for one impeller diameter (and Back Pullout) to be used for multiple pump installations — minimize inventory for critical services



Visit our Web site at www.gouldspumps.com

