

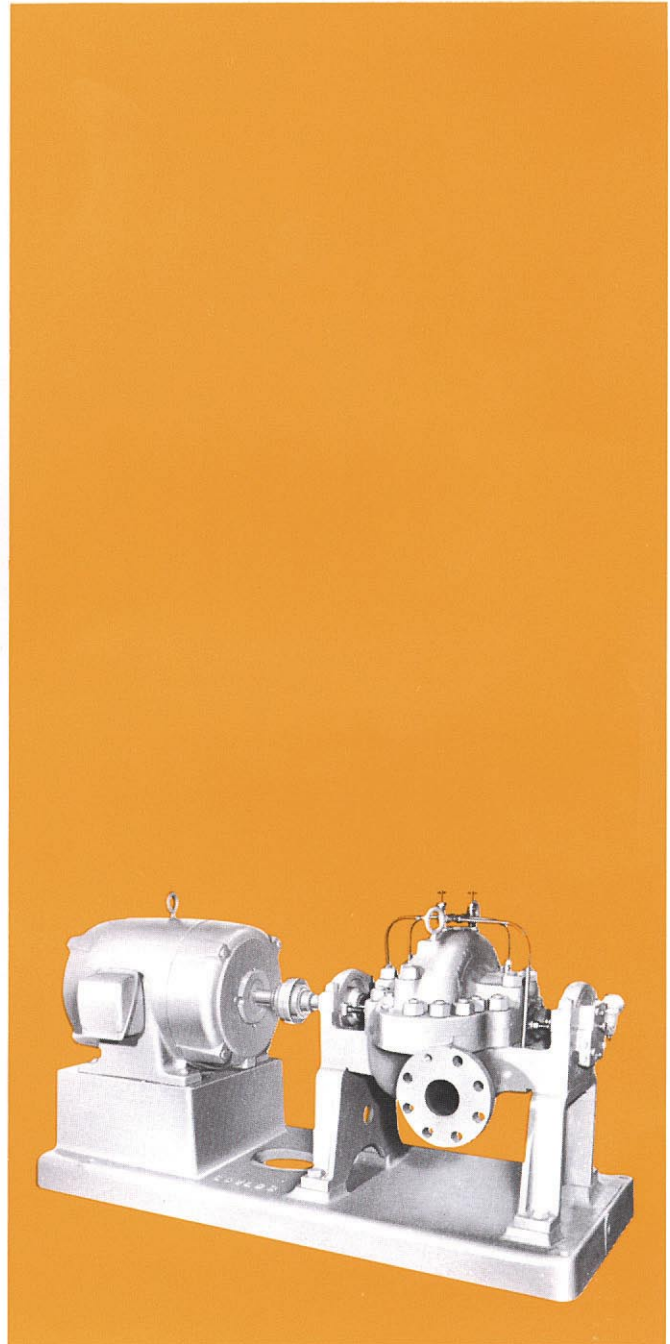

## Goulds Model 3316 Two Stage, Horizontally Split Case Pumps

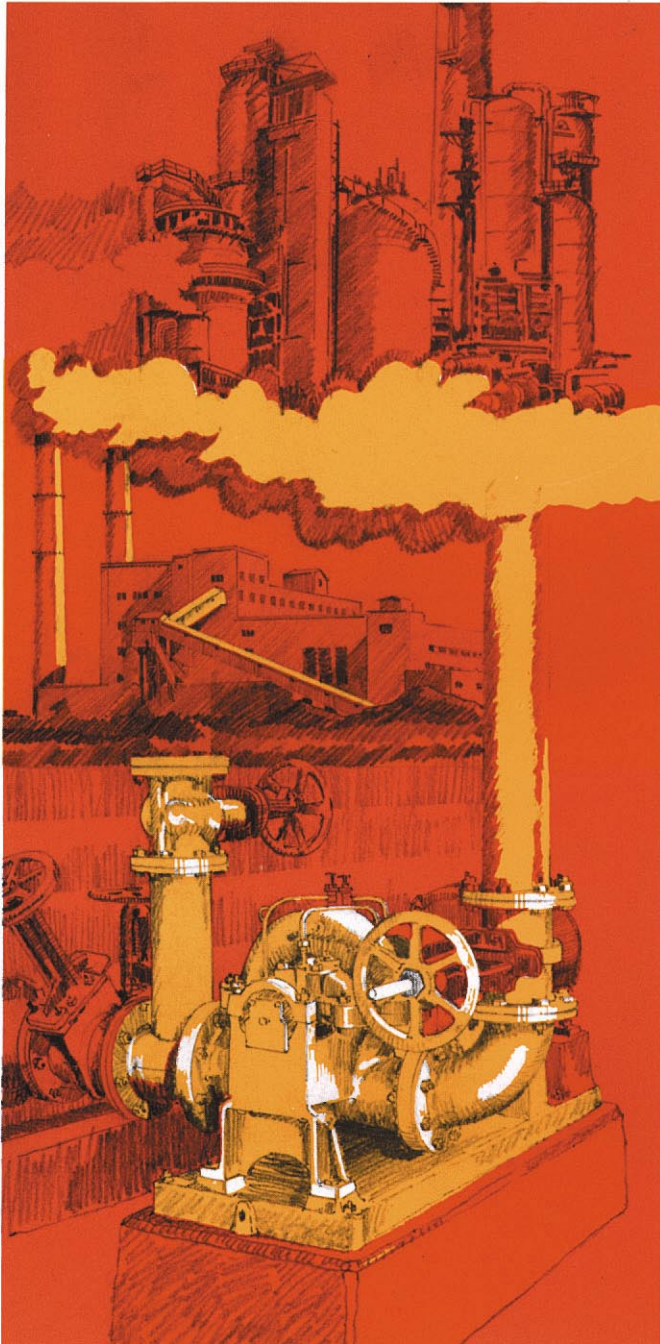

Goulds Pumps



**ITT Industries**  
*Engineered for life*



## Goulds Model 3316

**Two Stage, Horizontally Split Case Pumps Designed for Boiler Feed, Mine Dewatering and other Applications Requiring Moderately High Heads with a Wide Range of Service Conditions**

- Capacities to 3000 GPM (681 m<sup>3</sup>/h)
- Heads to 1000 feet (305 m)
- Temperatures to 350°F (177°C)
- Pressures to 550 PSIG (3792 kPa)

## Design Features

**Casing** Removal of upper half permits inspection, maintenance or removal of rotating element without disturbing piping or pump-to-motor alignment.

**Impellers** Hydraulically balanced — opposed for axial balance. Opposed cutwaters provide radial balance.

**Wear Rings** Easily replaced, protect against casing wear.

**Maximum Interchangeability** Reduces inventory requirements.

**Duplex Thrust Bearing** Provides high thrust capability.

**Materials of Construction** Available in all iron, all bronze, or bronze fitted. Most sizes available in steel and stainless steel.

## Services

Boiler Feed  
Mine De-Watering  
Booster  
High Pressure Process  
Condensate  
High Pressure Cleaning



# Model 3316 Two Stage, Horizontally Split Case Pumps

## Heavy Duty Design Features for Wide Range of Services

### RENEWABLE CASE WEAR RINGS

Permit easy maintenance of proper running clearances — protect against casing wear. Double lock in lower half casing to prevent rotation.

### UPPER HALF CASING

Permits inspection, maintenance or removal of complete rotating element without disturbing piping or alignment.

### HIGH THRUST CAPABILITY

with duplex thrust bearing and shaft lock nut. Provides long trouble-free operation under the wide service conditions which these pumps are exposed.

### SHAFT SEALING FLEXIBILITY

Packed stuffing box or variety of mechanical seals available. Conversion of one to the other can be accomplished in the field without machining. Equalizing piping keeps boxes at essentially suction pressure.

### STUFFING BOX BUSHING

Limits stuffing box pressure. Protects casing from wear. Easily replaceable. Secured with double lock in lower half casing.

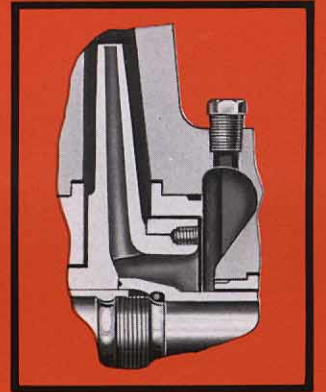
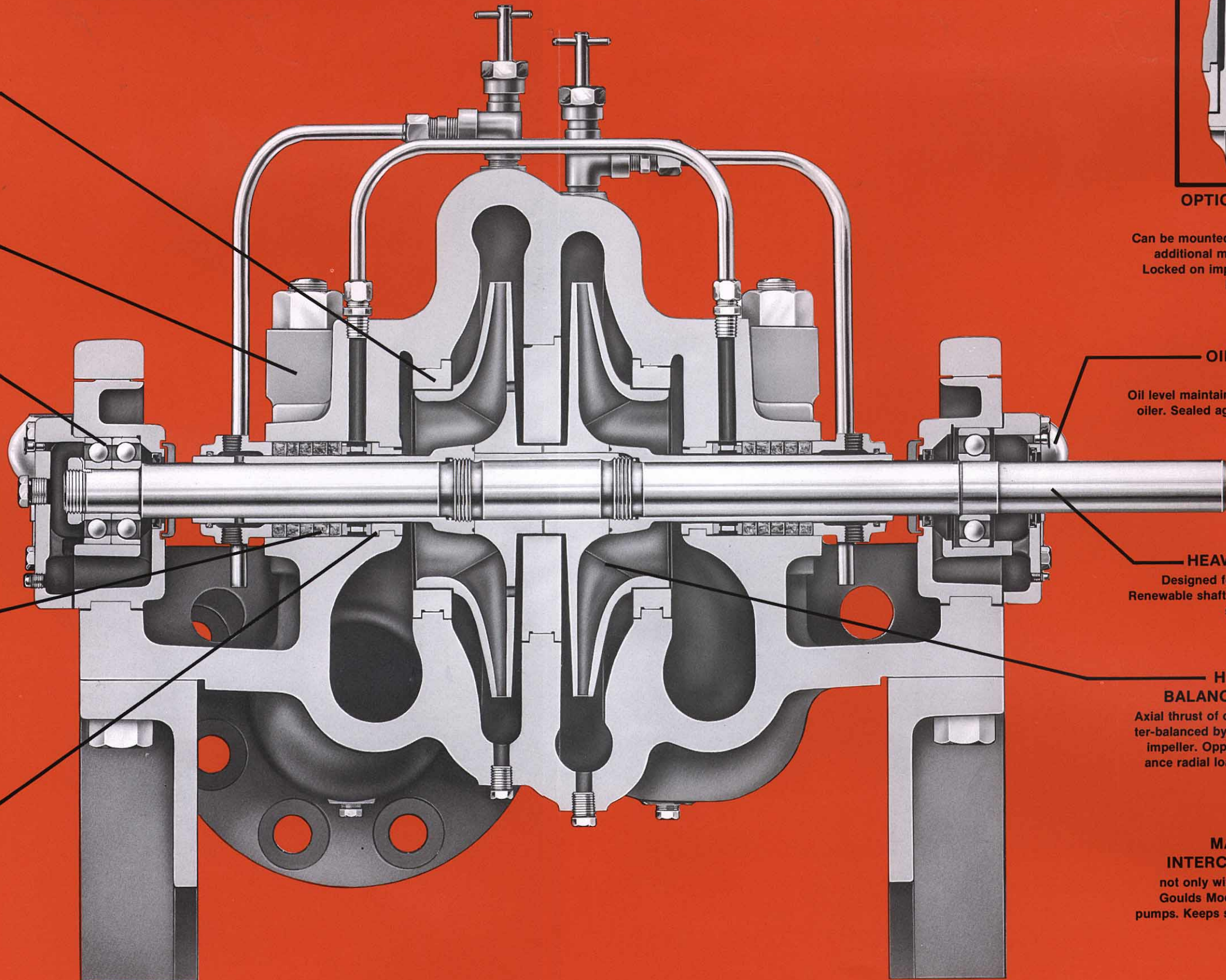

### OPTIONAL IMPELLER WEAR RINGS

Can be mounted on impeller without additional machining of impeller. Locked on impeller hub with stainless steel set screws.

### OIL LUBRICATION STANDARD

Oil level maintained by constant level oiler. Sealed against contamination.

### HEAVY DUTY SHAFT

Designed for toughest services. Renewable shaft sleeves fully protect shaft from pumpage.

### HYDRAULICALLY BALANCED IMPELLERS

Axial thrust of one impeller is counter-balanced by axial thrust of other impeller. Opposed cut-waters balance radial load reaction. Load on bearings is low.

### MAXIMUM PARTS INTERCHANGEABILITY

not only within the line but with Goulds Model 3405 single stage pumps. Keeps spare parts inventory to a minimum.

# Performance Curve Model 3316

3560 R.P.M. Except as noted.

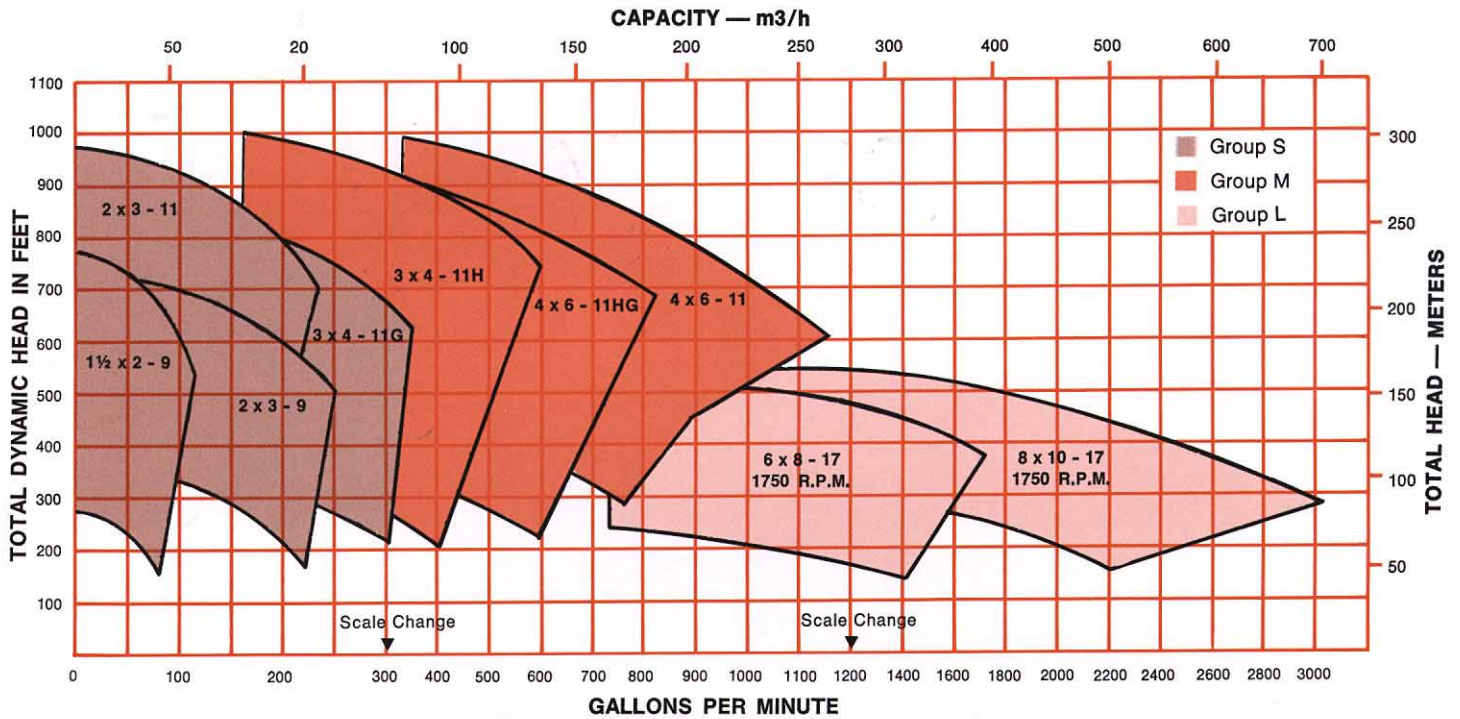

## Specifications

**Shaft** Short span keeps deflection to a minimum. Radius fillets are rolled into the shoulders at threaded portions to increase shaft fatigue strength. Radius fillets also machined into keyways to distribute stress more evenly along the shaft.

**Shaft Sleeves** Threaded against impeller hub, and free to expand or contract with temperature changes. One sleeve tightens against rotation, and is further secured by a set screw. Other sleeve is key driven. This unique locking design of sleeves permits field change of rotation without additional parts. An O-ring seal positively prevents leakage between shaft and sleeve.

**Casing Diaphragm** Forms dividing wall between stages and is renewable to maintain pump performance.

**Stuffing Box** Standard packed box has 5 rings of die-formed packing and a split lantern ring. Standard gland has tapped openings for quench or cooling liquid and a ring of packing to prevent liquid from spraying or traveling along shaft outside gland.

Unbalanced, balanced or double mechanical seals are available.

**Bearings** Thrust bearing is a duplex angular contact ball bearing. It carries radial load and any residual unbalanced thrust. The coupling end deep groove radial ball bearing is pressed on the shaft and is free to float axially carrying radial load only. Flood oil lubrication is standard.

**Rotation** Standard right hand construction. Left hand rotation available, rotation may be changed in field.

**Construction** Regularly available in bronze fitted, all iron or all bronze. Most sizes available in steel and stainless steel. Other materials available upon request.

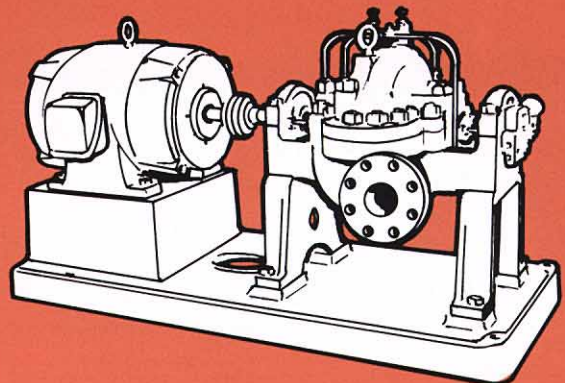

# Parts List and Materials of Construction

Item Number	Part Name	Material			
		Bronze-Fitted	All Iron	All Bronze	All 316SS
100	Casing (Upper & Lower)	Cast Iron	Cast Iron	Bronze	316SS
101	Impeller-Suction, 1st Stage	Bronze	Cast Iron	Bronze	316SS
102A	Equalizing Tubing	Copper	Steel	Copper	316SS
103 <sup>1</sup>	Casing Wear Ring	Bronze	Cast Iron	Bronze	Nitronic 60
104	Shaft Sleeve-Locking	316SS	420SS <sup>2</sup>	316SS	
107	Stuffing Box Split Gland	316SS			
112A	Ball Bearing-Thrust	Steel			
122	Shaft	SAE 4340		316SS	
123	Deflector	Glass-Impregnated Nylon			
125	Stuffing Box Bushing	Bronze	Cast Iron	Bronze	316SS
126	Shaft Sleeve	316SS	420SS	316SS	
136	Bearing Locknut	Steel			
142	Impeller Wear Ring (Not Illustrated)	Bronze	Cast Iron	Bronze	316SS
145	Impeller-Discharge, 2nd Stage	Bronze	Cast Iron	Bronze	316SS
146	Diaphragm	Bronze	Cast Iron	Bronze	Nitronic 60
168	Ball Bearing-Coupling End	Steel			
251	Constant Level Sight Oiler	Steel & Glass			
320	Set Screw-Impeller Wear Ring	303SS			
332A/333A	Oil Seal	Synthetic Rubber			
351	Casing Gasket	Non-Asbestos			
412A	O-ring-Impeller	TEFLON <sup>®</sup>			
412F	O-ring-Shaft	Buna Rubber			

<sup>1</sup> Used when impeller is furnished without wear rings.

<sup>2</sup> Flame hardened to 550 BHN.

® TEFLON is a registered trademark of DuPont.

## Materials of Construction

CODE	SPECIFICATION
1000	Cast Iron – ASTM A48 Class 25B
1001	Cast Iron – (No ASTM code)
1003	Cast Iron – ASTM A48 Class 30B
5445	Bronze – ASTM B505 C89320
1101	Bronze – ASTM B584-93A C87500
1618	Bismuth Bronze
AISI 303	Stainless – (wrought) ASTM A582 type 303
AISI 304	Stainless – (wrought) ASTM A276 type 304
316	Stainless – AISI 316 ASTM A744 CF-8M (cast), ASTM A276 type 316 (wrought)
6956	Colmonoy Coated 316
SAE 4340	ASTM, Gr. 4340

# Sectional View Model 3316

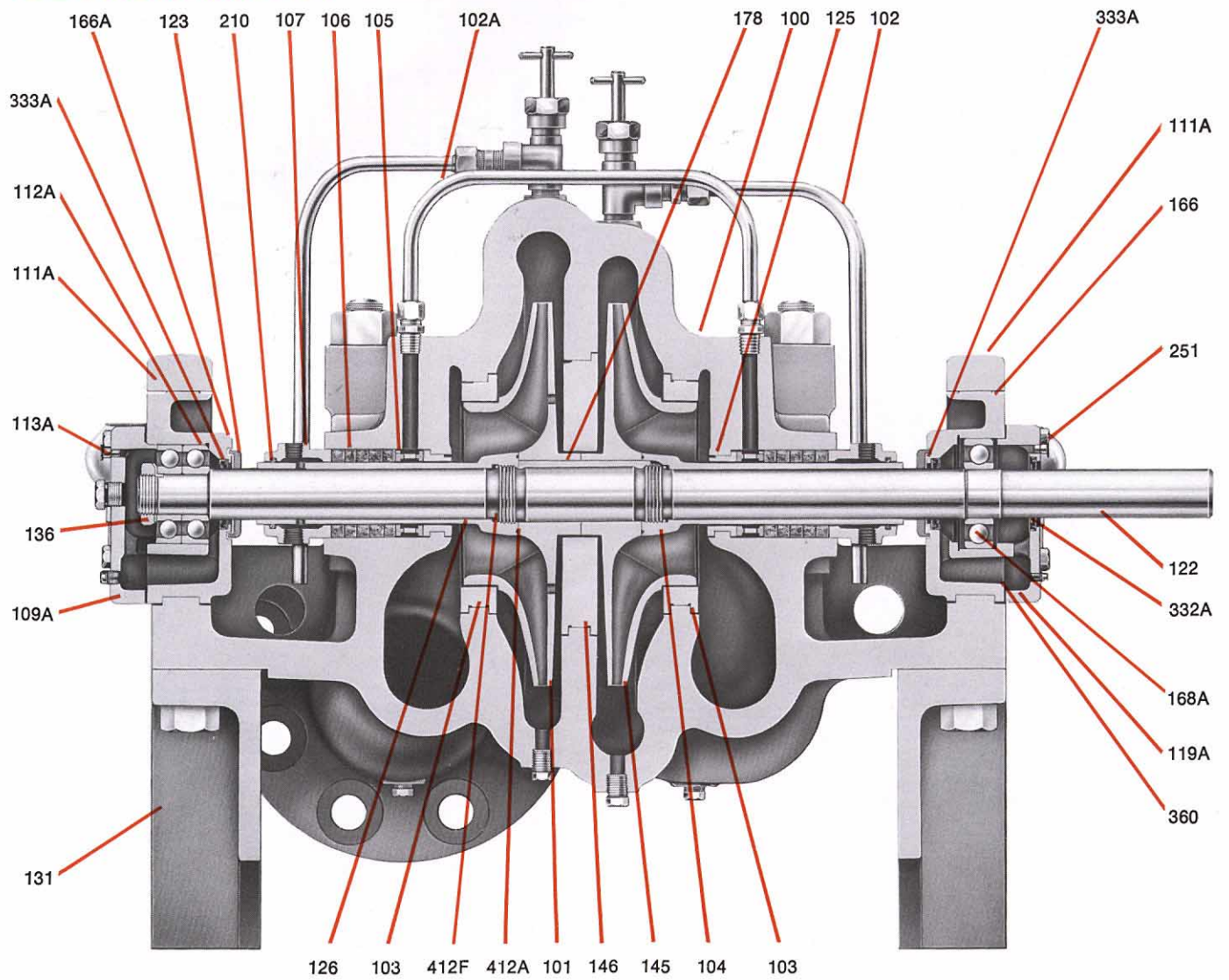

## Optional Constructions

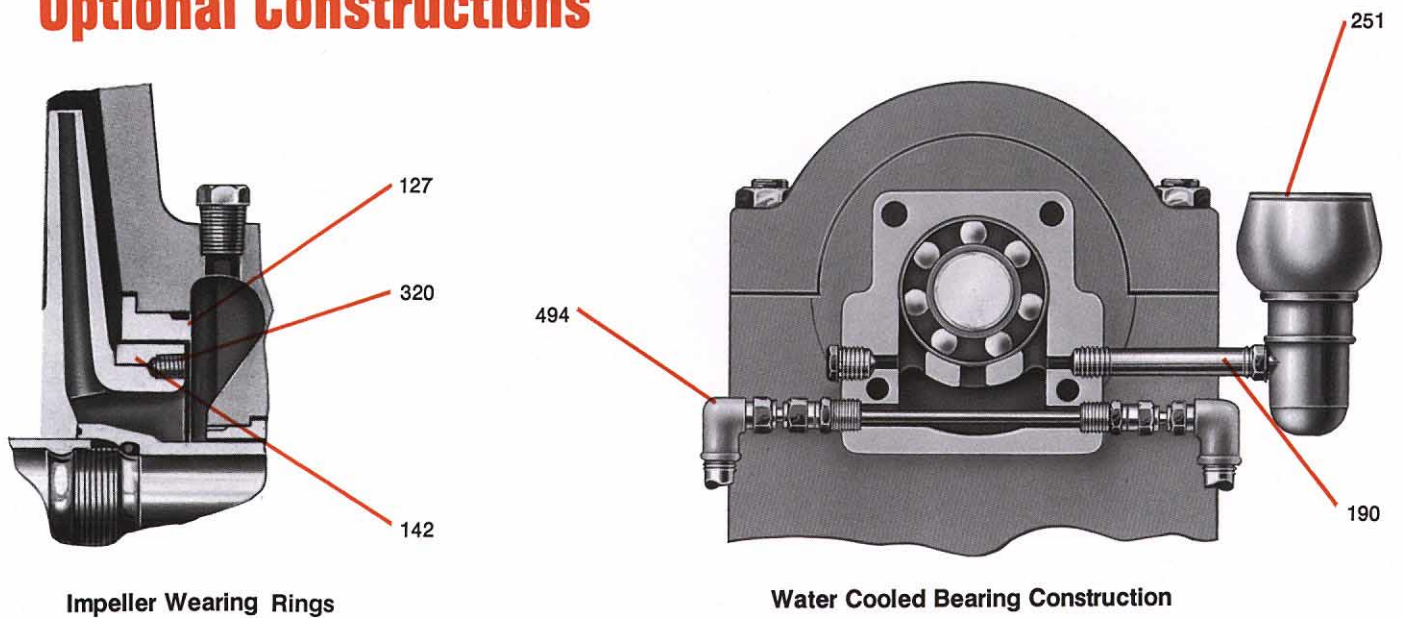

Impeller Wearing Rings

Water Cooled Bearing Construction

# Construction Details

Dimensions in inches. Metric equivalents in (mm).

		Group S		Group M				Group L		
		1½ x 2-9	2 x 3-9	2 x 3-11	3 x 4-11G	3 x 4-11H	4 x 6-11HG	4 x 6-11	6 x 8-17	8 x 10-17
†Maximum suction pressure is 240 PSIG. (1655kPa) *Gland quenching recommended on hot water above 212°F (100°C)										
Impeller	Weight-Bronze Fitted Bare Pump in Lbs. (Kg)	325 (147)	400 (181)	620 (281)	702 (318)	700 (318)	813 (369)	810 (367)	1820 (826)	2400 (1089)
	Weight-Bronze Impeller (Suction-1st Stage) Max. Dia. in lbs. (Kg)	9.9 (4.5)	11.6 (5.3)	17.8 (8.1)	19.9 (9.0)	19.7 (8.9)	23.0 (10.4)	21.5 (9.8)	50.0 (22.7)	58.0 (26.3)
	Weight-Bronze Impeller (Disch.-2nd Stg.) Max. Dia. in lbs. (Kg)	9.85 (4.5)	11.5 (5.2)	17.5 (7.9)	19.6 (8.9)	18.4 (8.4)	21.7 (9.8)	20.1 (9.1)	50.0 (22.7)	58.0 (26.3)
	Maximum Diameter Solids	5/32 (4)	7/32 (6)	5/32 (4)	5/32 (4)	1/4 (6)	1/4 (6)	15/32 (12)	19/32 (15)	27/32 (21)
Casing	Casing Thickness — Volute	3/4 (19)	3/4 (19)			1 (25)			1 1/8 (29)	1 1/4 (32)
	Casing Thickness — Side Walls	5/8 (16)	5/8 (16)			1 (25)			1 1/8 (29)	1 1/8 (29)
	Minimum Casing Corrosion Allowance	1/8 (3)	1/8 (3)			1/8 (3)			1/8 (3)	1/8 (3)
	Casing Capacity — Gallons (with Pump Assembled) (liters)	3/4 (3)	1 3/4 (7)	3 (11)	.4 (15)	4 (15)	6 3/4 (26)	6 3/4 (26)	19 (72)	28 3/4 (109)
Stuffing Box	Stuffing Box Bore	2" (51)		2 1/2" (64)				3 1/4" (83)		
	Stuffing Box Depth (To stuff. Box Bushing)	2 3/8" (59)		2 1 3/8" (71)				3 3/8" (86)		
	Stuffing Box Packing Size	5/16" x 3/16" (8 x 8)		3/8" x 3/8" (9.5 x 9.5)						
	Stuffing Box — No. of Packing Rings	5		5				6		
	Width of Lantern Ring	5/8" (16)		3/4" (19)				7/8" (22)		
Shaft	Shaft Dia. at Impellers	1 3/16" (30)		1 7/16" (40)				2 3/16" (56)		
	Shaft Dia. at Shaft Sleeve	1 1/16" (27)		1 7/16" (37)				2 1/16" (52)		
	Shaft Dia. at Coupling End	1 5/16" (24)		1 3/8" (35)				1 11/16" (49)		
	Outside Diameter of Shaft Sleeve	1 3/8" (35)		1 3/4" (44)				2 1/2" (63.5)		
General	Ball Bearing-Coupling End	305-S		307-S				310-S		
	Ball Bearing — Thrust End	7304P-DB		7306P-DB				7088P-DB		
	Bearing Centers	18 3/4" (476)		22 7/8" (581)				28 3/8" (721)		
	Maximum Shaft H. P. Per 100 RPM (kW)	2.57 (1.9)		9.7 (7.2)				27.1 (20.2)		
Press. Temp. Limits	†Maximum Total Working Pressure	See Pressure — Temperature Capability								
	Maximum Test Pressure	150% of Maximum Working Pressure at 100°F. (38°C)								
	Max. Liquid Temp. without Cooling and Quenching	250°F (121°C)								
	Max. Liquid Temp. with Quenching Gland and Bearing Cooling	350°F (177°C)								

## Pressure and Temperature Capability

CODE FOR PRESSURE-TEMPERATURE CHART		
Group	Curve	Casing Material
M	A	316SS A744 – CF8M
	B	Bronze 93A – C87500
	C	Cast Iron ASTM A48 Class 30
S	D	316SS A744 – CF8M
	E	Bronze 93A – C87500
	F	Cast Iron ASTM A48 Class 30
L	G	316SS A744 – CF8M
	H	Bronze 93A – C87500
	I	Cast Iron ASTM A48 Class 30

### NOTES:

Maximum suction pressure: 240 PSIG  
Ratings shown reflect pump limitations only. User should insure that connecting piping including mating flanges are adequate for anticipated service.  
Suction and discharge flanges drilled to match 300 lb. steel, bronze and 250 lb. AISI cast iron.

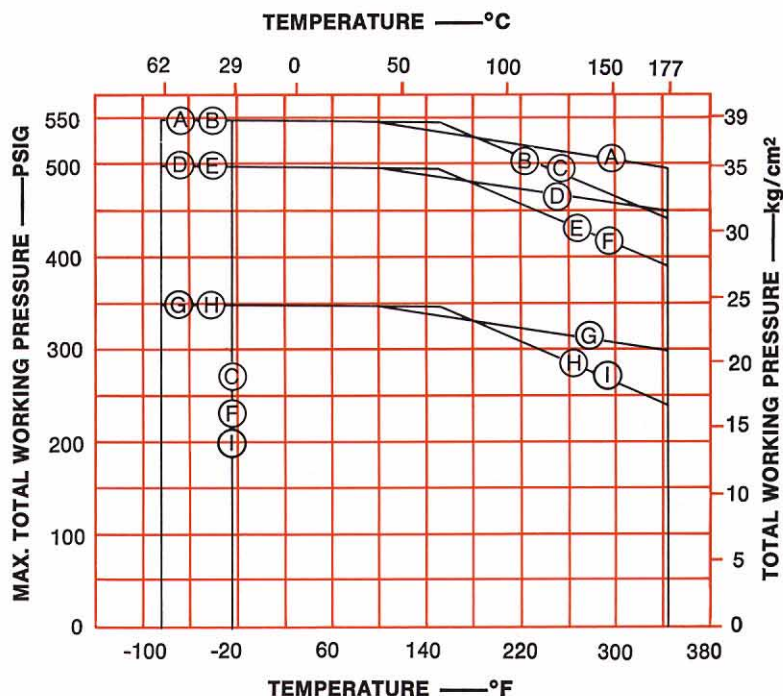

# Dimensions Model 3316

All dimensions in inches and (mm). Not to be used for construction.  
Right hand rotation illustrated.

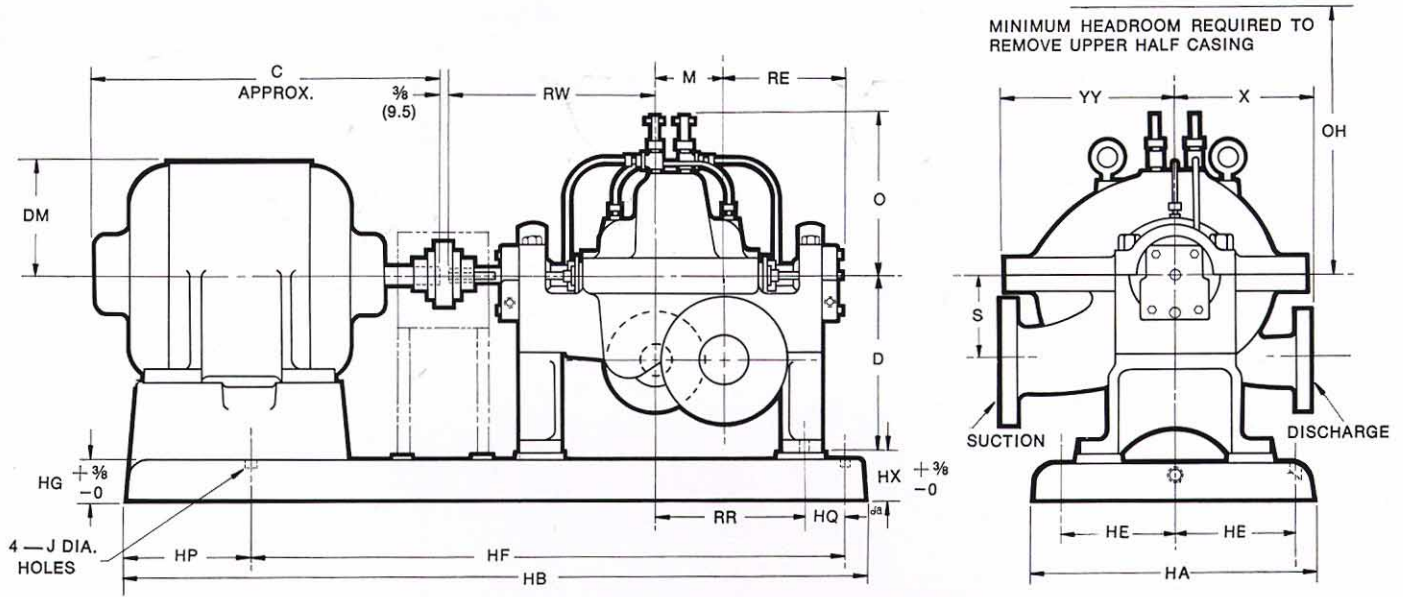

## DIMENSIONS DETERMINED BY PUMP

Group	Disch. Size	Suct. Size	Casing Class	O	OH	D	X	YY	S	RR	RW	M	RE	Weight Lbs. (Kg)
S	1 1/2 (38)	2 (51)	9	9 1/2 (241)	15 1/4 (387)	11 1/2	8 1/4 (210)	10 1/8 (257)	4 5/8 (117)	9 19/16 (249)	13 13/16 (351)	3 1/2 (89)	8 1/8 (227)	325 (147)
	2 (51)	3 (76)	9	10 (254)	15 3/4 (400)	11 1/2	8 3/4 (222)	11 1/4 (286)	5 1/2 (140)	9 15/16 (252)	13 11/16 (348)	4 3/8 (111)	9 1/4 (230)	400 (181)
M	2 (51)	3 (76)	11	11 1/4 (286)	17 3/4 (451)	16	10 (254)	12 1/4 (311)	4 1/2 (114)	12 (305)	17 (432)	5 (127)	9 3/4 (248)	620 (281)
	3 (76)	4 (102)	11	11 3/4 (298)	18 1/4 (464)	16	11 (279)	13 (330)	5 1/2 (140)	12 (305)	17 (432)	6 (152)	8 3/4 (222)	700 (318)
	4 (102)	6 (152)	11	12 1/2 (318)	19 (483)	16	11 1/2 (292)	16 (406)	6 1/2 (165)	12 5/8 (321)	16 3/8 (416)	7 1/8 (181)	8 1/8 (206)	810 (367)
L	6 (152)	8 (203)	17	17 1/4 (438)	26 1/4 (667)	22	16 (406)	20 1/2 (521)	9 (229)	16 3/16 (252)	18 11/16 (475)	9 3/16 (249)	9 1/4 (235)	1820 (826)
	8 (203)	10 (254)	17	18 3/8 (467)	27 3/8 (695)	22	17 1/2 (445)	23 1/2 (597)	10 1/4 (260)	16 5/8 (422)	18 1/4 (464)	11 (279)	8 1/2 (216)	2400 (1089)

## DIMENSIONS DETERMINED BY MOTOR AND BEDPLATE

Group	Bedplate No.	Bedplate No.	C	HA	HB	HE	HF	HG	J	HP	HX	HQ	DM	Bedplate Weight Lbs. (Kg)
S	1	143T thru 215T	12 1/2 to 19 1/2 (318) to (495)	18 (457)	43 1/2 (1105)	7 7/8 (200)	38 1/2 (978)	2 1/2 (63.5)	3/4 (19)	3 3/4 (95)	3 (76)	2 3/8 (60)	3 1/2 to 6 (89) to (152)	200 (91)
	2	154T thru 266T	22 1/2 to 27 (572) to (686)		50 1/2 (1283)		39 1/4 (997)			10 (254)			6 1/2 to 7 1/2 (165) to (191)	215 (98)
	3	324TS thru 265T	27 to 34 (686) to (864)	23 (584)	54 1/2 (1384)	10 1/4 (260)	42 3/4 (1086)	3 1/2 (89)		10 1/2 (267)	4 (102)	2 11/16 (68)	9 to 9 1/2 (229) to (241)	255 (116)
	4	404TST thru 405TS	34 to 35 1/2 (864) to (902)		57 1/4 (1454)		44 3/4 (1137)			11 1/4 (286)			11 (279)	275 (125)
M	1	182T thru 266T	14 1/2 to 27 (368) to (686)	24 (610)	57 1/4 (1454)	10 1/2 (267)	50 (1270)	3 1/2 (89)	7/8 (22)	5 3/4 (146)	4 (102)	3 1/16 (78)	5 to 7 1/2 (127) to (191)	410 (186)
	2	324T thru 365T	27 to 34 (686) to (864)		61 (1549)		48 1/4 (1226)			11 1/4 (286)			9 to 9 1/2 (229) to (241)	440 (200)
	3	404TS thru 447TS	34 to 46 1/2 (864) to (1181)	26 (660)	69 3/4 (1772)	11 1/2 (292)	53 1/2 (1359)	4 (102)		14 3/4 (375)	4 1/2 (114)	11 to 12 1/2 (279) to (318)	580 (263)	
L	1	254T thru 365T	22 1/2 to 34 (572) to (864)	33 (838)	68 (1727)	14 3/4 (375)	55 1/4 (1403)	4 1/2 (114)	1 (25)	11 (279)	5 (127)	3 3/8 (86)	6 1/2 to 9 1/2 (165) to (241)	850 (386)
	2	404TS thru 447TS	34 to 46 1/2 (864) to (1181)		76 1/2 (1943)		59 13/16 (1519)			11 to 12 1/2 (279) to (318)			1050 (476)	
	3	447T	48 (1218)	79 1/2 (2019)	61 3/4 (1568)	12 1/2 (318)	1200 (544)							



Visit our website at [www.gouldspumps.com](http://www.gouldspumps.com)

# Goulds Pumps

---



**ITT Industries**  
*Engineered for life*