

| ITEM | DESCRIPTION |
|------|---------------------|
| 1 | O-RING |
| 2 | GLAND SEAM GASKET |
| 3 | ROTARY COLLAR |
| 4 | SET SCREWS |
| 5 | O-RING |
| 6 | ROTARY FACE |
| 7 | O-RING |
| 8 | STATIONARY FACE |
| 9 | RETAINING CLIP |
| 10 | O-RING |
| 11 | CENTERING SPACERS |
| 12 | SPRINGS |
| 13 | COLLAR SEAM GASKET |
| 14 | GLAND |
| 15 | CAP SCREW / WASHERS |
| 16 | ANTI-ROTATION PIN |

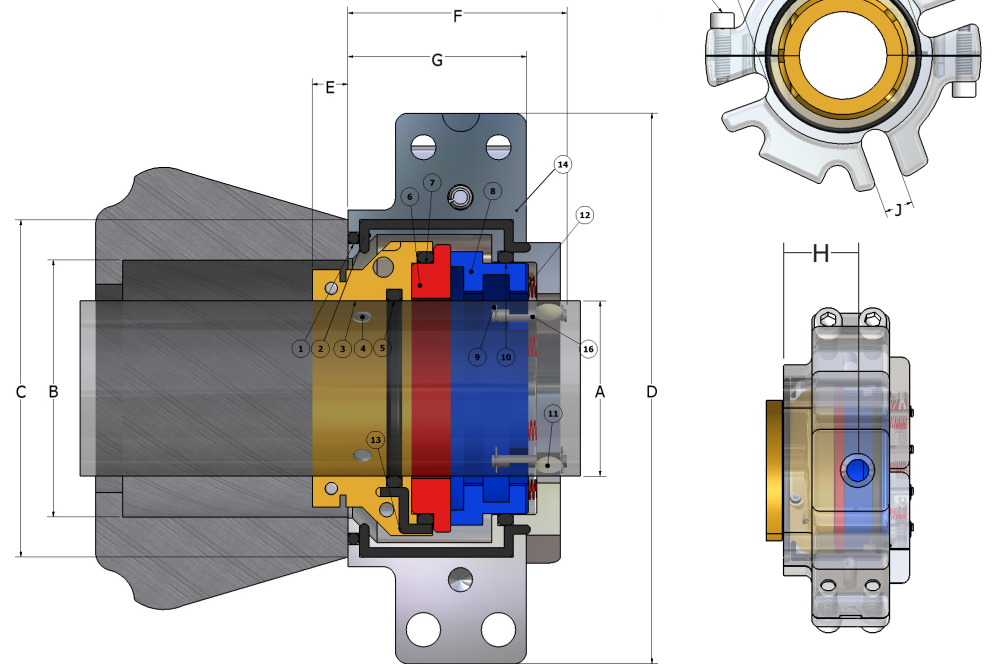

1200S

PPC's SINGLE SPLIT SEAL

| A | B (MIN) | B (MAX) | C | D | E | F | G | H | I | J | K | L |
|-------|---------|---------|------|-------|------|------|------|------|-----|-----|------|------|
| 1.500 | 2.25 | 2.50 | 2.75 | 5.00 | 2.50 | 2.19 | 1.78 | 1.13 | .28 | .56 | 2.94 | .66 |
| 1.625 | 2.38 | 2.63 | 2.88 | 5.00 | 2.63 | 2.19 | 1.78 | 1.13 | .28 | .56 | 3.06 | .66 |
| 1.750 | 2.50 | 2.75 | 3.00 | 5.50 | 2.75 | 2.19 | 1.78 | 1.13 | .28 | .56 | 3.19 | .66 |
| 1.875 | 2.63 | 2.88 | 3.13 | 5.50 | 2.88 | 2.19 | 1.78 | 1.13 | .28 | .56 | 3.31 | .66 |
| 1.937 | 2.75 | 3.00 | 3.25 | 5.50 | 3.00 | 2.19 | 1.78 | 1.13 | .28 | .69 | 3.44 | .66 |
| 2.000 | 2.75 | 3.00 | 3.25 | 5.50 | 3.00 | 2.19 | 1.78 | 1.13 | .28 | .56 | 3.44 | .66 |
| 2.125 | 2.88 | 3.13 | 3.38 | 6.00 | 3.13 | 2.19 | 1.78 | 1.13 | .28 | .69 | 3.56 | .66 |
| 2.187 | 2.94 | 3.19 | 3.44 | 6.25 | 3.19 | 2.19 | 1.78 | 1.13 | .28 | .69 | 3.62 | .66 |
| 2.250 | 3.00 | 3.25 | 3.50 | 6.25 | 3.25 | 2.19 | 1.78 | 1.13 | .28 | .69 | 3.69 | .66 |
| 2.375 | 3.13 | 3.38 | 3.63 | 6.50 | 3.38 | 2.19 | 1.78 | 1.13 | .28 | .69 | 3.81 | .66 |
| 2.500 | 3.25 | 3.75 | 4.00 | 6.50 | 3.50 | 2.19 | 1.78 | 1.13 | .28 | .69 | 4.06 | .66 |
| 2.625 | 3.38 | 3.88 | 4.13 | 6.62 | 3.62 | 2.19 | 1.78 | 1.13 | .28 | .69 | 4.19 | .66 |
| 2.750 | 3.63 | 4.25 | 4.69 | 7.75 | 3.94 | 2.56 | 2.06 | 1.34 | .38 | .69 | 5.03 | .72 |
| 2.875 | 3.75 | 4.38 | 4.81 | 7.88 | 4.05 | 2.56 | 2.06 | 1.34 | .38 | .72 | 5.15 | .72 |
| 2.937 | 3.81 | 4.44 | 4.88 | 8.00 | 4.11 | 2.56 | 2.06 | 1.34 | .38 | .72 | 5.21 | .72 |
| 3.000 | 3.88 | 4.50 | 4.94 | 8.00 | 4.19 | 2.56 | 2.06 | 1.34 | .38 | .72 | 5.28 | .72 |
| 3.250 | 4.13 | 4.75 | 5.19 | 8.25 | 4.44 | 2.56 | 2.06 | 1.34 | .38 | .72 | 5.53 | .72 |
| 3.375 | 4.25 | 4.88 | 5.31 | 8.38 | 4.56 | 2.56 | 2.06 | 1.34 | .38 | .72 | 5.66 | .72 |
| 3.500 | 4.38 | 5.00 | 5.44 | 8.50 | 4.69 | 2.56 | 2.06 | 1.34 | .38 | .81 | 5.78 | .72 |
| 3.625 | 4.50 | 5.13 | 5.56 | 8.63 | 4.81 | 2.56 | 2.06 | 1.34 | .38 | .81 | 5.91 | .72 |
| 3.750 | 4.63 | 5.25 | 5.69 | 8.75 | 4.94 | 2.56 | 2.06 | 1.34 | .38 | .81 | 5.94 | .72 |
| 3.875 | 4.75 | 5.31 | 5.81 | 8.88 | 5.06 | 2.56 | 2.06 | 1.34 | .38 | .81 | 6.07 | .72 |
| 4.000 | 4.88 | 5.50 | 5.94 | 9.00 | 5.19 | 2.56 | 2.06 | 1.34 | .38 | .81 | 6.28 | .72 |
| 4.250 | 5.13 | 5.75 | 6.19 | 9.25 | 5.44 | 2.56 | 2.06 | 1.34 | .38 | .81 | 6.44 | .72 |
| 4.375 | 5.25 | 5.88 | 6.32 | 9.38 | 5.56 | 2.56 | 2.06 | 1.34 | .38 | .81 | 6.56 | .72 |
| 4.500 | 5.38 | 6.00 | 6.44 | 9.50 | 5.69 | 2.56 | 2.06 | 1.34 | .38 | .81 | 6.69 | .72 |
| 4.750 | 5.63 | 6.25 | 6.69 | 9.75 | 5.94 | 2.56 | 2.06 | 1.34 | .38 | .81 | 7.03 | .72 |
| 5.000 | 5.88 | 7.00 | 7.50 | 11.00 | 6.50 | 3.56 | 3.00 | 1.88 | .50 | .94 | 7.63 | 1.12 |
| 5.250 | 6.13 | 7.25 | 7.75 | 11.25 | 6.75 | 3.56 | 3.00 | 1.88 | .50 | .94 | 7.88 | 1.12 |
| 5.375 | 6.25 | 7.38 | 7.88 | 11.38 | 6.88 | 3.56 | 3.00 | 1.88 | .50 | .94 | 8.00 | 1.12 |
| 5.500 | 6.38 | 7.50 | 8.00 | 11.50 | 7.00 | 3.56 | 3.00 | 1.88 | .50 | .94 | 8.13 | 1.12 |
| 6.000 | 6.88 | 8.00 | 8.50 | 12.00 | 7.50 | 3.56 | 3.00 | 1.88 | .50 | .94 | 8.63 | 1.12 |
| 6.250 | 7.13 | 8.25 | 8.75 | 12.25 | 7.75 | 3.56 | 3.00 | 1.88 | .50 | .94 | 8.88 | 1.12 |
| 6.500 | 7.38 | 8.50 | 9.00 | 12.50 | 8.00 | 3.56 | 3.00 | 1.88 | .50 | .94 | 9.13 | 1.12 |
| 7.000 | 7.88 | 9.00 | 9.50 | 13.00 | 8.50 | 3.56 | 3.00 | 1.88 | .50 | .94 | 9.63 | 1.12 |

Also available in popular metric sizes.

WARRANTY: PPC seals and seal parts are guaranteed to be free from defects in material and workmanship and are guaranteed to render satisfactory service when used for the purpose for which they are designed.

PPC's SINGLE SPLIT SEAL 1200S

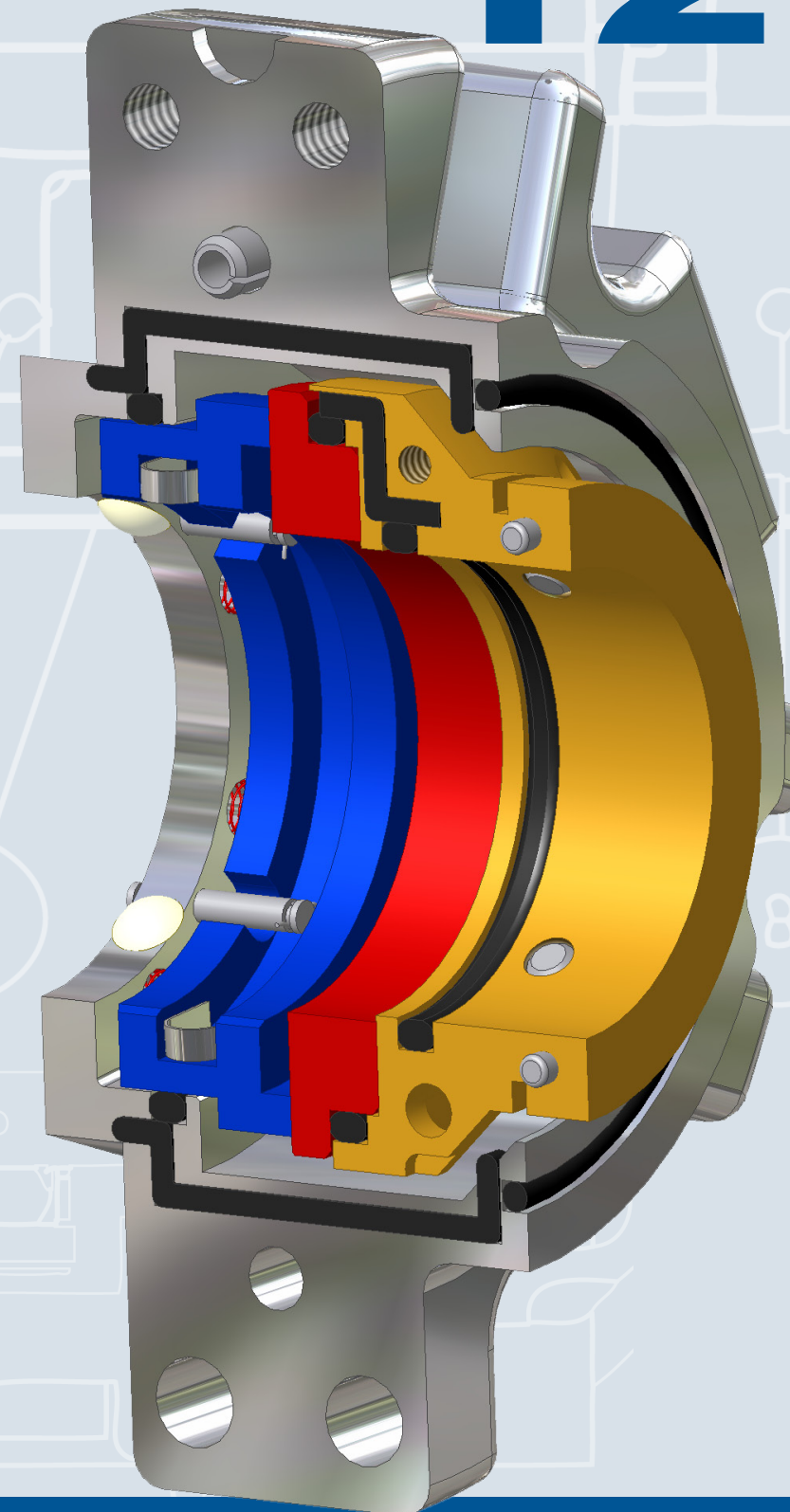

- Made in the U.S.A.
- Minimize heat generation due to balance design.
- Substantial savings in down-time. The 1200S is ready to run in a fraction of the time of other split seals, and cartridge seals.
- Can be installed without dismantling equipment.
- Repair kits are available for field repair of all 1200S seals.
- Less power consumption than packing resulting in a significant dollar savings \$\$\$.

ADVANTAGES OF A SPLIT SEAL

1. Installed without dismantling equipment.
2. Reduced maintenance and inventory costs.
3. Won't wear or score shaft sleeve.
4. No packing gland to re-tighten.
5. Operates with less leakage than packing.
6. Lasts longer than packing.
7. Less housekeeping than packing.
8. Lower power consumption than packing (smaller carbon footprint)
9. Field repairable
10. Increases safety & reduces liability

EQUIPMENT APPLICATIONS

1. Pumps
2. Agitators
3. Blenders
4. Separators
5. Refiners
6. Dryers
7. Mixers
8. Any difficult to access rotating equipment.

APPLICABLE INDUSTRIES

1. Pulp and paper
2. Power generation
3. Wastewater treatment
4. Mining
5. Grain processing
6. Pipeline
7. Water systems
8. Petroleum/ Chemical (non-hazardous)

DYNAMIC O-RING design provides clean area for the stationary component to advance beneath o-ring.

STATIONARY SPRINGS ARE ISOLATED from pumped fluid and unaffected if gland is misaligned.

GLAND IS SELF-CENTERING. Spacers are affixed in place preventing their accidental removal.

ROTARY UNIT IS LOCKED TO SHAFT BY SET SCREWS virtually eliminating slippage of collar.

ROTARY COLLAR POSITIONS WITHOUT MEASURING. Disposable spacer allows for quick, easy positioning.

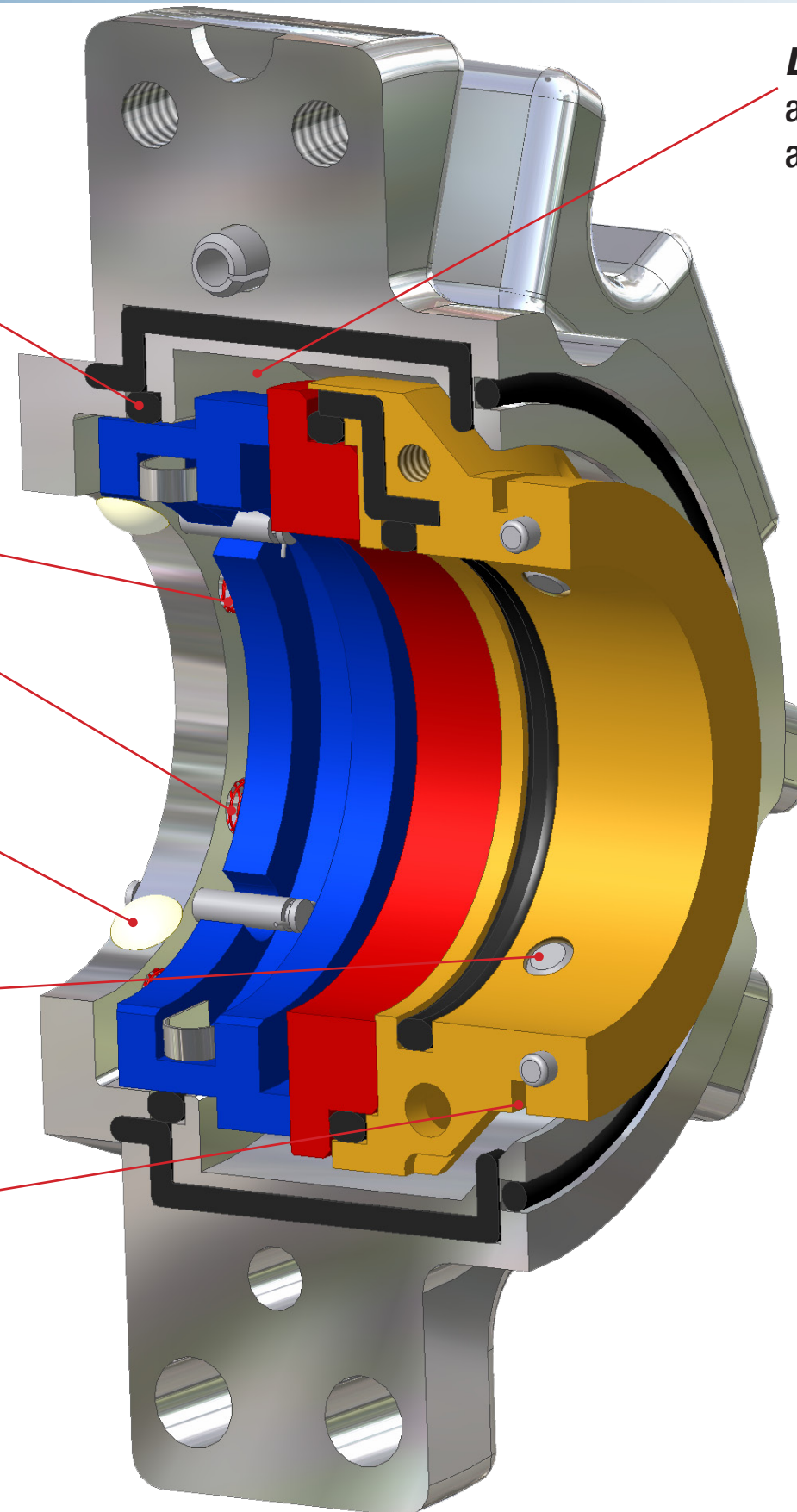

LARGE INTERNAL CLEARANCES allow for excessive radial or axial movement.

NO ADHESIVE INVOLVED IN INSTALLATION which simplifies and speeds the procedure.

TECHNICAL DATA:

| | |
|----------------------|-------------------------------------|
| Sizes | 1 1/2" thru 7" * |
| Temperatures | 250° F. |
| Operating Conditions | 1 1/2" - 2 5/8": 200 PSI, 3600 RPM |
| | 2 3/4" - 2 5/8": 150 PSI, 1750 RPM. |
| | 4 7/8" - 7": 100 PSI, 875 RPM |

* For Larger Sizes Contact PPC Mechanical Seals

MATERIALS OF CONSTRUCTION:

| | |
|-------------------|---|
| Face Combinations | Carbon vs Silicon Carbide Silicon Carbide vs Silicon Carbide |
| Springs | Alloy C276 |
| Elastomers | Ethylene Propylene, Fluoroelastomer, *AFLAS® |
| Rotary Collar | 316SS |
| Gland | 316SS |
| Bolts | 316SS |

*Trademark of Asahi Glass